

PHILIPS

Data handbook



Electronic
components
and materials

Components and materials

Part 3a September 1978

FM tuners

Television tuners

Surface acoustic wave filters

COMPONENTS AND MATERIALS

Part 3a

September 1978

FM tuners

Television tuners and aerial input assemblies

Surface acoustic wave filters

Contents list



DATA HANDBOOK SYSTEM

Our Data Handbook System is a comprehensive source of information on electronic components, sub-assemblies and materials; it is made up of three series of handbooks each comprising several parts.

ELECTRON TUBES

BLUE

SEMICONDUCTORS AND INTEGRATED CIRCUITS

RED

COMPONENTS AND MATERIALS

GREEN

The several parts contain all pertinent data available at the time of publication, and each is revised and reissued periodically.

Where ratings or specifications differ from those published in the preceding edition they are pointed out by arrows. Where application information is given it is advisory and does not form part of the product specification.

If you need confirmation that the published data about any of our products are the latest available, please contact our representative. He is at your service and will be glad to answer your inquiries.

This information is furnished for guidance, and with no guarantee as to its accuracy or completeness; its publication conveys no licence under any patent or other right, nor does the publisher assume liability for any consequence of its use; specifications and availability of goods mentioned in it are subject to change without notice; it is not to be reproduced in any way, in whole or in part without the written consent of the publisher.

October 1977

ELECTRON TUBES (BLUE SERIES)

Part 1a	December 1975	ET1a 12-75	Transmitting tubes for communication, tubes for r.f. heating Types PE05/25 to TBW15/25
Part 1b	August 1977	ET1b 08-77	Transmitting tubes for communication, tubes for r.f. heating, amplifier circuit assemblies
Part 2a	November 1977	ET2a 11-77	Microwave tubes Communication magnetrons, magnetrons for microwave heating, klystrons, travelling-wave tubes, diodes, triodes T-R switches
Part 2b	May 1978	ET2b 05-78	Microwave semiconductors and components Gunn, Impatt and noise diodes, mixer and detector diodes, backward diodes, varactor diodes, Gunn oscillators, sub- assemblies, circulators and isolators
Part 3	January 1975	ET3 01-75	Special Quality tubes, miscellaneous devices
Part 4	March 1975	ET4 03-75	Receiving tubes
Part 5a	March 1978	ET5a 03-78	Cathode-ray tubes Instrument tubes, monitor and display tubes, C.R. tubes for special applications
Part 5b	May 1975	ET5b 05-75	Camera tubes, image intensifier tubes
Part 6	January 1977	ET6 01-77	Products for nuclear technology Channel electron multipliers, neutron tubes, Geiger-Müller tubes
Part 7a	March 1977	ET7a 03-77	Gas-filled tubes Thyratrons, industrial rectifying tubes, ignitrons, high-voltage rectifying tubes
Part 7b	March 1977	ET7b 03-77	Gas-filled tubes Segment indicator tubes, indicator tubes, switching diodes, dry reed contact units
Part 8	May 1977	ET8 05-77	TV picture tubes
Part 9	March 1978	ET9 03-78	Photomultiplier tubes; phototubes

SEMICONDUCTORS AND INTEGRATED CIRCUITS (RED SERIES)

Part 1a August 1978	SC1a 08-78	Rectifier diodes, thyristors, triacs Rectifier diodes, voltage regulator diodes (> 1,5 W), transient suppressor diodes, rectifier stacks, thyristors, triacs
Part 1b May 1977	SC1b 05-77	Diodes Small signal germanium diodes, small signal silicon diodes, special diodes, voltage regulator diodes (< 1,5 W), voltage reference diodes, tuner diodes
Part 2 November 1977	SC2 11-77	Low-frequency and dual transistors
Part 3 January 1978	SC3 01-78	High-frequency, switching and field-effect transistors
Part 4a June 1976	SC4a 06-76	Special semiconductors* Transmitting transistors, field-effect transistors, dual transistors, microminiature devices for thick and thin-film circuits
Part 4b September 1978	SC4b 09-78	Devices for optoelectronics Photosensitive diodes and transistors, light emitting diodes, photocouplers, infrared sensitive devices, photoconductive devices
Part 4c July 1978	SC4c 07-78	Discrete semiconductors for hybrid thick and thin-film circuits
Part 5a November 1976	SC5a 11-76	Professional analogue integrated circuits
Part 5b March 1977	SC5b 03-77	Consumer integrated circuits Radio-audio, television
Part 6 October 1977	SC6 10-77	Digital integrated circuits LOCMOS HE4000B family
Signetics integrated circuits 1978		Bipolar and MOS memories Bipolar and MOS microprocessors Analogue circuits

* The most recent information on field-effect transistors can be found in SC3 01-78, on dual transistors in SC2 11-77, and on microminiature devices in SC4c 07-78.

COMPONENTS AND MATERIALS (GREEN SERIES)

Part 1	June 1977	CM1 06-77	Assemblies for industrial use High noise immunity logic FZ/30-series, counter modules 50-series, NORbits 60-series, 61-series, circuit blocks 90-series, circuit block CSA70(L), PLC modules, input/output devices, hybrid circuits, peripheral devices, ferrite core memory products
Part 2a	October 1977	CM2a 10-77	Resistors Fixed resistors, variable resistors, voltage dependent resistors (VDR), light dependent resistors (LDR), negative temperature coefficient thermistors (NTC), positive temperature coefficient thermistors (PTC), test switches
Part 2b	February 1978	CM2b 02-78	Capacitors Electrolytic and solid capacitors, film capacitors, ceramic capacitors, variable capacitors
Part 3	January 1977	CM3 01-77	Radio, audio, television Loudspeakers, components for black and white television, components for colour television
Part 3a	September 1978	CM3a 09-78	FM tuners, television tuners, surface acoustic wave filters
Part 4a	September 1978	CM4a 09-78	Soft ferrites Ferrites for radio, audio and television, beads and chokes, Ferroxcube potcores and square cores, Ferroxcube transformer cores
Part 4b	December 1976	CM4b 12-76	Piezoelectric ceramics, permanent magnet materials
Part 6	April 1977	CM6 04-77	Electric motors and accessories Small synchronous motors, stepper motors, miniature direct current motors
Part 7	September 1971	CM7 09-71	Circuit blocks Circuit blocks 100 kHz-series, circuit blocks 1-series, circuit blocks 10-series, circuit blocks for ferrite core memory drive
Part 8	February 1977	CM8 02-77	Variable mains transformers
Part 9	March 1976	CM9 03-76	Piezoelectric quartz devices
Part 10	April 1978	CM10 04-78	Connectors

F.M. tuners



F.M. TUNER with diode tuning

QUICK REFERENCE DATA

Supply voltage (d. c.)	15 V
Frequency range	87,5 - 108 MHz
Intermediate frequency	10,7 MHz

APPLICATION

This tuner is intended for use in hi-fi radio sets.
The required range can be obtained by limiting the tuning voltage.
The tuners are provided with a four-fold i. f. circuit.



MECHANICAL DATA

Dimensions in mm

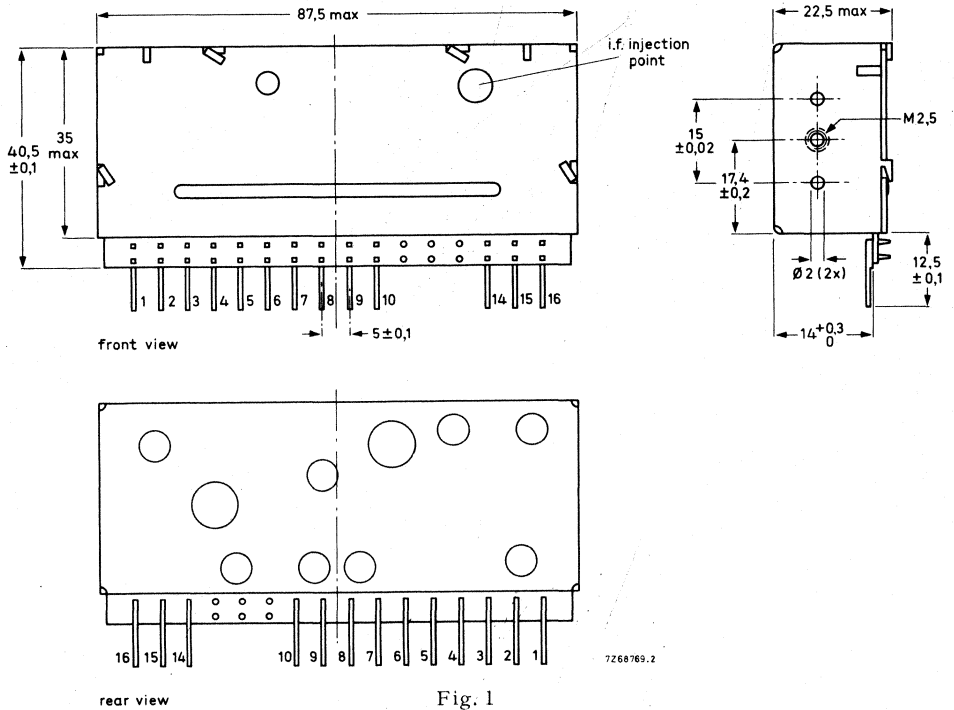

Note : The left and right sides are identical.

Mounting

The tuner can be mounted in any position.

Marking

The tuner is marked with the 12-digit catalogue number and the production code.

ELECTRICAL DATA

Unless otherwise specified all electrical values apply at an ambient temperature of 25 ± 5 °C, a relative humidity of $60 \pm 15\%$ and a supply voltage of 15 ± 1 V.

Semiconductors

r.f. amplifier	BF324
mixer	BF324
oscillator	BF324
tuning diodes	BB110B (2x), BB110G

Ambient temperature range

operating	0 to +55 °C
storage	-20 to +70 °C

Supply voltage (d. c.)

+15 ± 1 V

Current drawn from +15V supply

8,75 ± 0,5 mA

Tuning voltage range

+3 to +27 V

Frequency range

87,5 to 108 MHz

voltage (V d. c.)	frequency (MHz)	
3,00	87	} ± 300 kHz
3,30	88	
4,00	90	
4,80	92	
5,80	94	
6,95	96	
8,35	98	

voltage (V d. c.)	frequency (MHz)	
10,05	100	} ± 300 kHz
12,10	102	
14,65	104	
17,80	106	
21,80	108	
27,00	110	

Intermediate frequency

10,7 MHz

The oscillator frequency is higher than the signal frequency

I. F. bandwidth (3 dB)

180 kHz

S 300

typ. 27 dB

Input impedance, asymmetrical

75 Ω

Output impedance

300 Ω

Padding deviation

≤ 350 kHz

Power gain

typ. 20 dB

Noise figure

typ. 6,5 dB

I. F. suppression

≥ 80 dB

Image rejection

≥ 50 dB



Repeat spot suppression (RSS) ¹⁾	≥ 75 dB
Double beat suppression (DBS) ²⁾	≥ 75 dB
Continuous beat suppression (CBS) ³⁾	≥ 60 dB
Shift of oscillator frequency	
at a change of the supply voltage from 15 to 12 V	≤ 100 kHz
at a change of the ambient temperature from 0 to +55 °C	≤ 5 kHz/°C; typ. 2,5 kHz/°C
after resistance to moisture test (IEC 68-2-30, test Db, 21 days, 40 °C; recovery time 1 h)	≤ 1250 kHz; typ. 600 kHz
Reduction of power gain at a change of the supply voltage from 15 to 12 V	≤ 3,5 dB
Oscillator radiation and oscillator terminal voltage	according to C. I. S. P. R. recommen- dation no. 24/3; measured according to I. E. C. 106.

¹⁾ Suppression of a signal arising by conversion of harmonics of the oscillator signal and those of a strong aerial signal. Reference voltage: 10 μV (aerial e. m. f.); aerial impedance: 75 Ω.

²⁾ Suppression of a signal arising from two strong aerial signals. Reference voltage: 10 μV (aerial e. m. f.); aerial impedance: 75 Ω.

³⁾ Suppression of a signal arising from the harmonic of two strong aerial signals with a frequency difference equal to the intermediate frequency.

ADDITIONAL INFORMATION

Aligning of the i. f. circuit

The tuner is fully h.f. and i.f. aligned in the factory.

However, if an adaptation to the receiver is necessary, aligning should be done in the following way.

1. Adjust the tuning voltage to +8,35 V.
2. Apply a generator signal (≤ 100 mV, $10,7$ MHz ± 2 kHz) to the i. f. injection point (Fig. 1) via the circuit shown in Fig. 3.

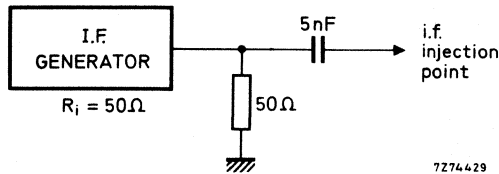
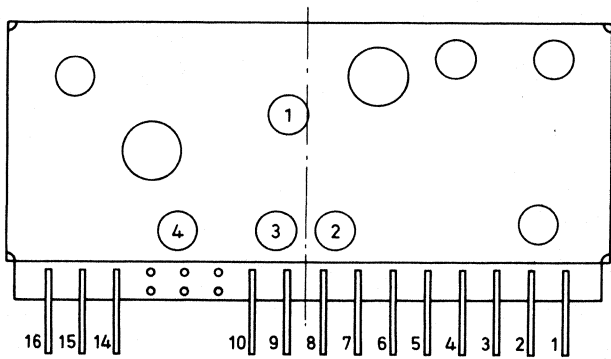

Fig. 3

3. Adjust the i. f. coils in sequence 1 to 4 (Fig. 4) to maximum output.



rear view

Fig. 4

4. Apply a generator signal (100 mV, $10,7$ MHz ± 500 kHz) to the i. f. injection point for checking the i. f. bandwidth; top of the curve at $10,7$ MHz ± 5 kHz. Check the i. f. bandwidth (3 dB) and S 300: their values must be as specified in "Electrical Data".

Measurement of power gain

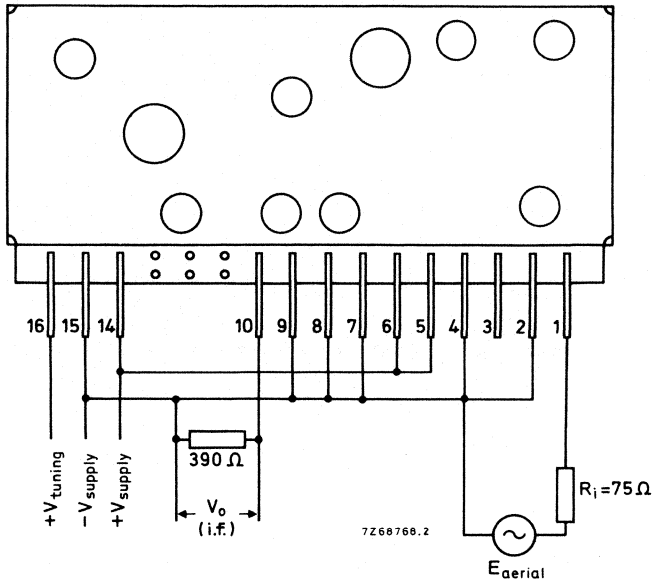

Fig. 5

The r. f. input signal: ≤ 1 mV (r. m. s.)

The gain = $20 \log \frac{\text{i. f. voltage across } R (= 390 \Omega)}{\text{aerial e. m. f.}}$

F.M. TUNER

with diode tuning

QUICK REFERENCE DATA

Supply voltage (d. c.)	15 V
Frequency range	87,5 - 108 MHz
Intermediate frequency	10,7 MHz

APPLICATION

This tuner is intended for use in hi-fi radio sets.
The required range can be obtained by limiting the tuning voltage.
The tuner has been provided with a two-fold i. f. circuit.



MECHANICAL DATA

Dimensions in mm

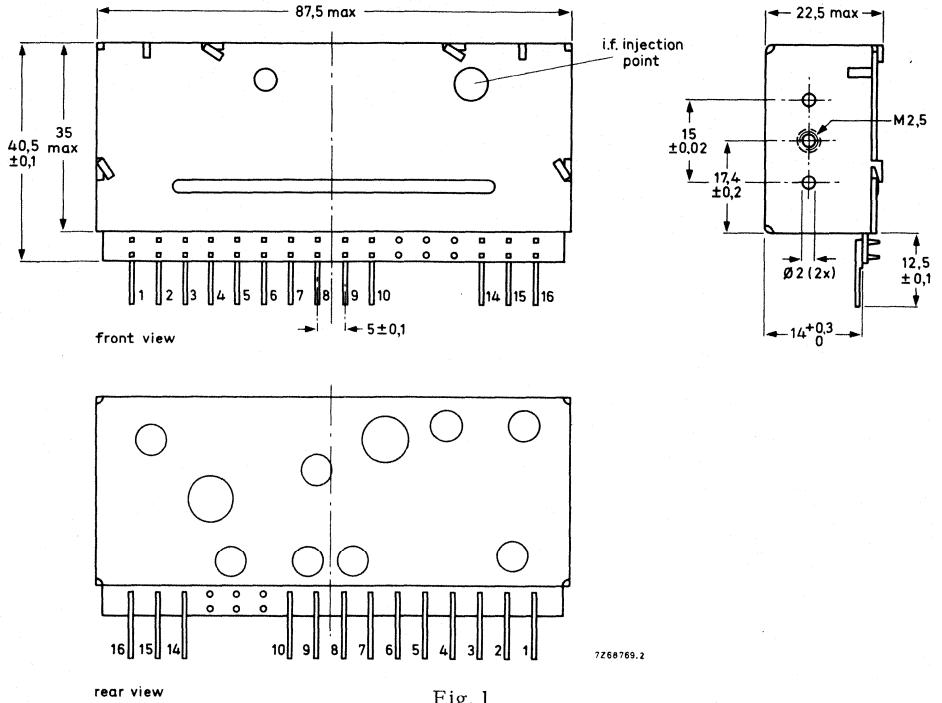

Fig. 1

Note : The left and right sides are identical.

Mounting

The tuner can be mounted in any position.

Marking

The tuner is marked with the 12-digit catalogue number and the production code.

ELECTRICAL DATA

Unless otherwise specified all electrical values apply at an ambient temperature of 25 ± 5 °C, a relative humidity of $60 \pm 15\%$ and a supply voltage of 15 ± 1 V.

Semiconductors

r. f. amplifier	BF324
mixer	BF324
oscillator	BF324
tuning diodes	BB110B (2x), BB110G

Ambient temperature range

operating	0 to +55 °C
storage	-20 to +70 °C

Supply voltage (d. c.)+15 \pm 1 V**Current drawn from +15 V supply**typ. 8,75 \pm 0,5 mA**Tuning voltage range**

+3 to +27 V

Frequency range

87,5 to 108 MHz

voltage (V d. c.)	frequency (MHz)	
3,00	87	} \pm 300 kHz
3,30	88	
4,00	90	
4,80	92	
5,80	94	
6,95	96	
8,35	98	

voltage (V d. c.)	frequency (MHz)	
10,05	100	} \pm 300 kHz
12,10	102	
14,65	104	
17,80	106	
21,80	108	
27,00	110	

Intermediate frequency

10,7 MHz

The oscillator frequency is higher than the signal frequency

I. F. bandwidth (3 dB)

220 kHz

S 300

typ. 16 dB

Input impedance, asymmetrical75 Ω **Output impedance**300 Ω **Padding deviation** \leq 350 kHz**Power gain**

typ. 30 dB

Noise figure

typ. 6,5 dB

I. F. suppression \geq 80 dB**Image rejection** \geq 50 dB

Repeat spot suppression (RSS) ¹⁾	≥ 75 dB
Double beat suppression (DBS) ²⁾	≥ 75 dB
Continuous beat suppression (CBS) ³⁾	≥ 60 dB
Shift of oscillator frequency at a change of the supply voltage from 15 to 12 V	≤ 100 kHz
at a change of the ambient temperature from 0 to +55 °C	≤ 5 kHz/°C; typ. 2,5 kHz/°C
after resistance to moisture test (IEC 68-2-30, test Db, 21 days, 40 °C; recovery time 1 h)	≤ 1250 kHz; typ. 600 kHz
Reduction of power gain at a change of the supply voltage from 15 to 12 V	≤ 3,5 dB
Oscillator radiation and oscillator terminal voltage	according to C. I. S. P. R. recommen- dation no. 24/3; measured according to I. E. C. 106.

¹⁾ Suppression of a signal arising by conversion of harmonics of the oscillator signal and those of a strong aerial signal. Reference voltage: 10 μV (aerial e. m. f.); aerial impedance: 75 Ω.

²⁾ Suppression of a signal arising from two strong aerial signals. Reference voltage: 10 μV (aerial e. m. f.); aerial impedance: 75 Ω.

³⁾ Suppression of a signal arising from the harmonic of two strong aerial signals with a frequency difference equal to the intermediate frequency.

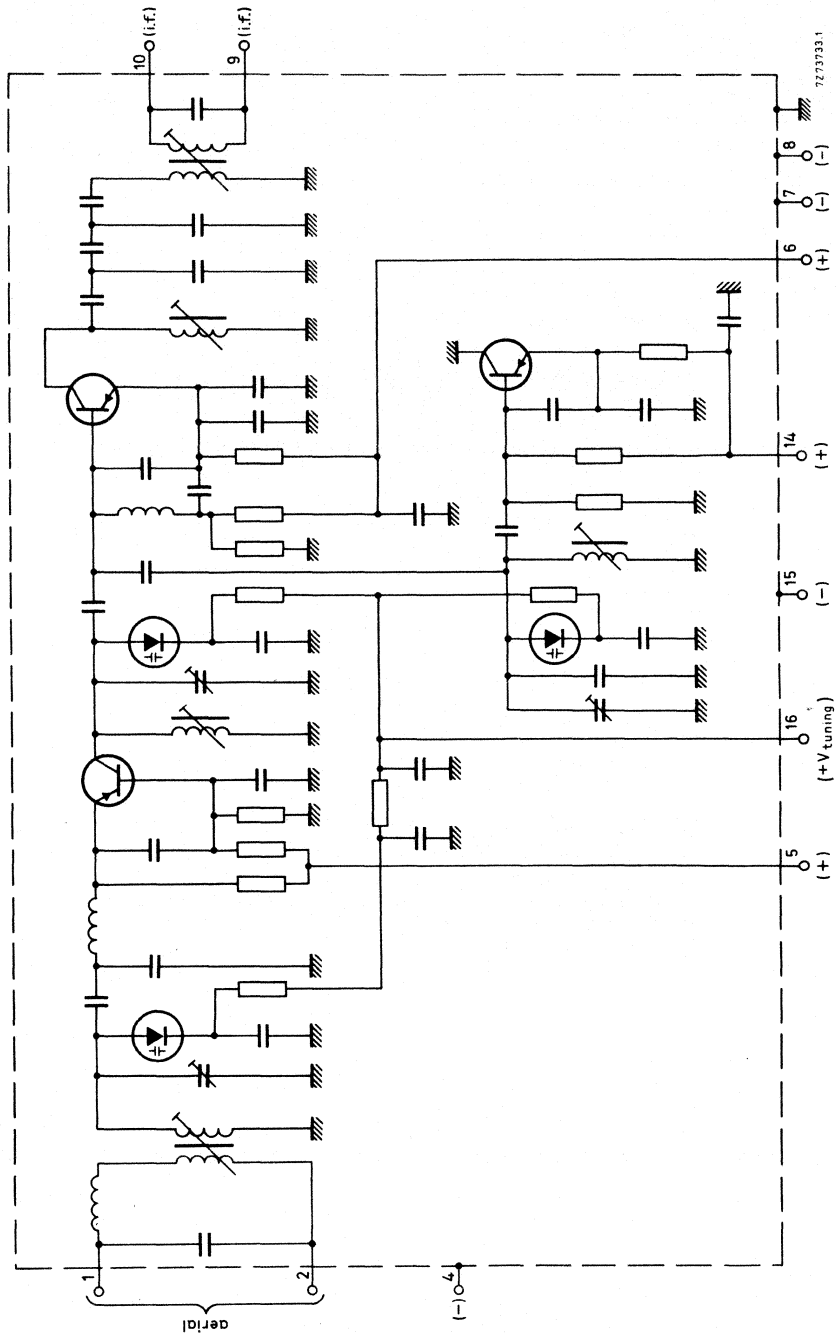

Fig. 2



ADDITIONAL INFORMATION

Aligning of the i. f. circuit

The tuner is fully h.f. and i.f. aligned in the factory.

However, if an adaptation to the receiver is necessary, aligning should be done in the following way.

1. Adjust the tuning voltage to +8,35 V.
2. Apply a generator signal (≤ 100 mV, $10,7$ MHz ± 2 kHz) to the i. f. injection point (Fig. 1) via the circuit shown in Fig. 3.

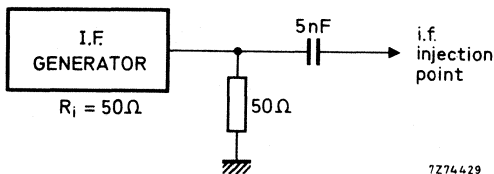
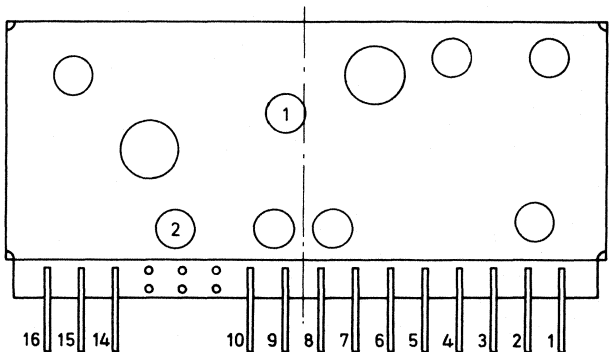

Fig. 3

3. Adjust the i. f. coils in sequence 1 to 2 (Fig. 4) to maximum output.



rear view

Fig. 4

4. Apply a generator signal (100 mV, $10,7$ MHz ± 500 kHz) to the i. f. injection point for checking the i. f. bandwidth; top of the curve at $10,7$ MHz ± 5 kHz.
Check the i. f. bandwidth (3 dB) and S 300: their values must be as specified in "Electrical Data".

Measuring the power gain

Fig. 5

The r. f. input signal: ≤ 1 mV (r. m. s.)

The gain = $20 \log \frac{\text{i. f. voltage across } R (= 820 \Omega)}{\text{aerial e. m. f.}}$

F.M. TUNERS with diode tuning

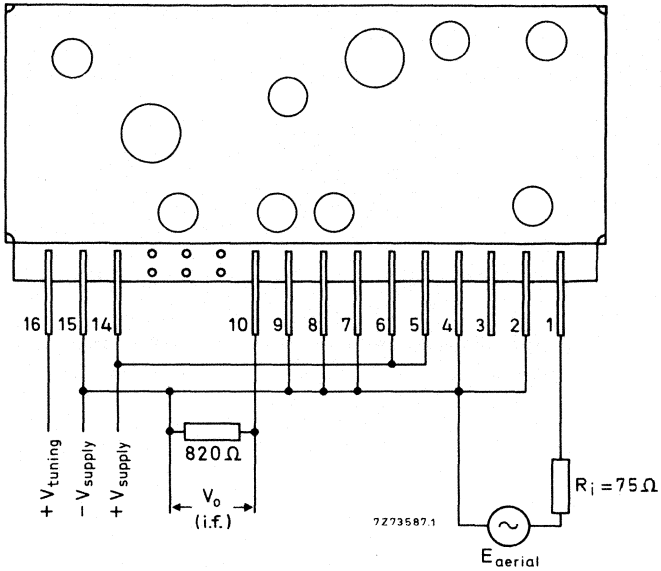
QUICK REFERENCE DATA

F.M. tuners for European and American band	
Tuner FD1 without a. f. c.	
Tuner FD1A with a. f. c.	
Supply voltage (d. c.)	12 V
Frequency range	87,5 to 108 MHz

GENERAL

These tuners are intended for use in hi-fi radio sets. The advantage of these tuners is the excellent big signal handling.

The wanted range can be obtained by limiting the tuning voltage.

The tuners are equipped with silicon transistors and silicon variable capacitance diodes.

MECHANICAL DATA

Dimensions in mm

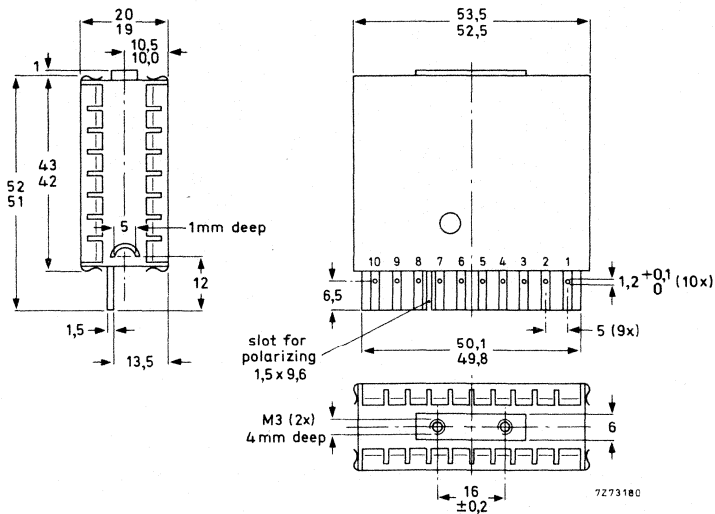

Fig. 1

The tuner can be fixed in a connector or soldered directly to a printed-wiring board.

ELECTRICAL DATA

Semiconductors	2 x BF324 1 x BF451 4 x BB104 1 x BB106 (only for FD1A)
Ambient temperature range, operating storage	0 to +50 °C -20 to +60 °C
Supply voltage	+12 ± 1 V
Current drawn from +12 V supply	9 mA
Tuning voltage range (Fig. 2)	+3,8 to +28 V
Frequency range	87,5 to 108 MHz
Intermediate frequency	10,7 MHz The oscillator frequency is higher than the signal frequency
I. F. bandwidth	270 kHz
Input impedance, asymmetrical symmetrical	60 Ω 240 Ω
Output impedance for critical coupling	470 Ω
Gain at 98 MHz	min. 27 dB (typ. 30 dB)
Noise figure at 98 MHz	max. 7,5 dB (typ. 6 dB)
Reflection factor at 98 MHz	0,35
I. F. suppression at 98 MHz	min. 76 dB (typ. 83 dB)
Image rejection at 98 MHz	min. 64 dB (typ. 72 dB)
Repeat spot suppression (RSS, Fig. 3) 1)	min. 70 dB (typ. 82 dB)
Double beat suppression (DBS, Fig. 3) 2)	min. 70 dB (typ. 80 dB)
Continuous beat suppression (CBS, Fig. 4) 3)	62 dB
Minimum input signal (e. m. f.) at a shift of the oscillator frequency of max. 20 kHz	1 V
Shift of the oscillator frequency at a change of the supply voltage of 1 V	max. 30 kHz

1) Suppression of a signal arising by conversion of harmonics of the oscillator signal and those of a strong aerial signal.

2) Suppression of a signal arising from two strong aerial signals.

3) Suppression of a signal arising from the harmonic of two strong aerial signals with a frequency difference equal to the intermediate frequency.

Temperature coefficient of the oscillator	see Fig. 5
Oscillator radiation	according to VDE 0872.7 and 0872.8
A. F. C. sensitivity (only for FD1A)	see Figs. 6 and 7

Graphs

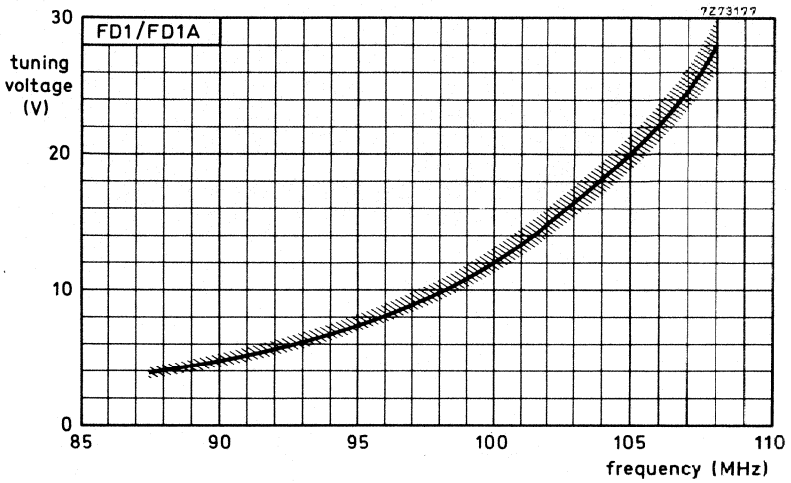

Fig. 2. Tuning voltage as a function of signal frequency.

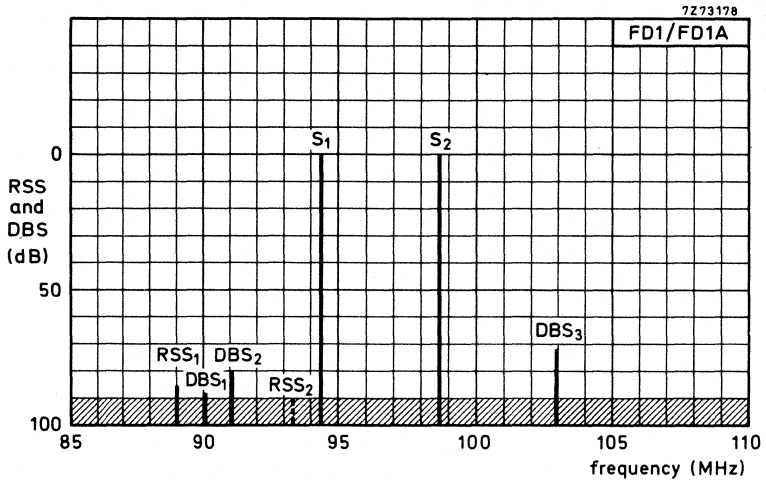

Fig. 3. Location of transmitter frequencies, repeat spots and double beats. Reference signals S_1 and S_2 : 10 μ V.

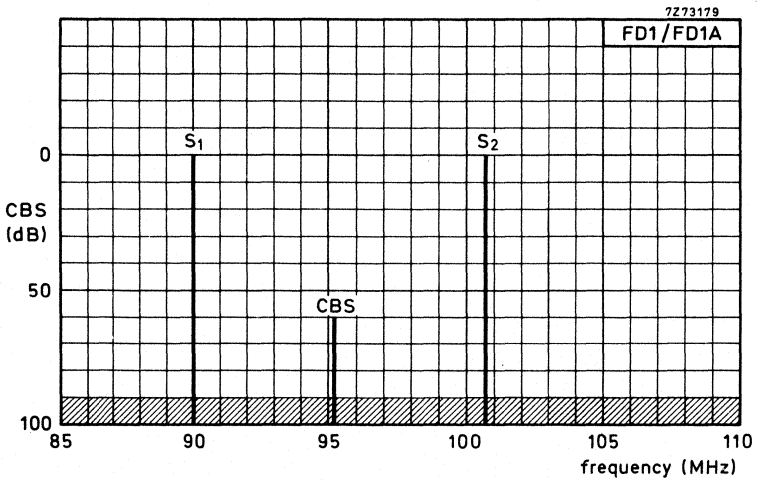

Fig. 4. Location of transmitter frequencies and measuring frequency for measuring the continuous beat suppression (CBS).

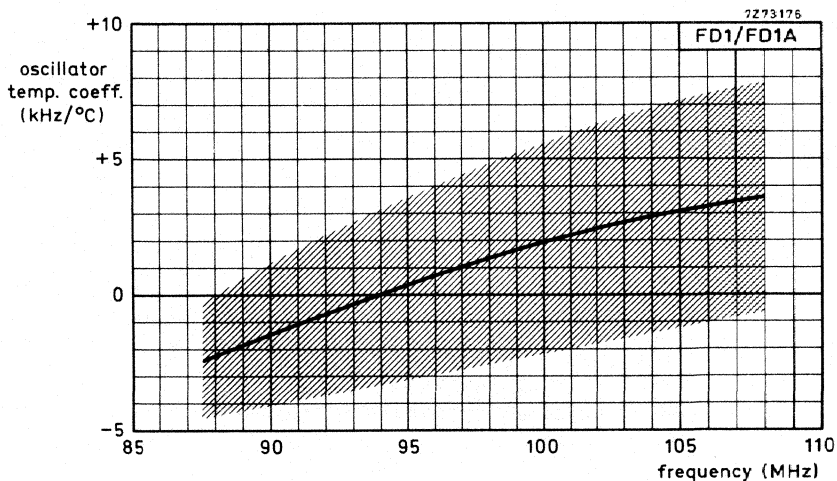

Fig. 5 Oscillator temperature coefficient as a function of signal frequency, measured in the temperature range 15 to 25 °C.

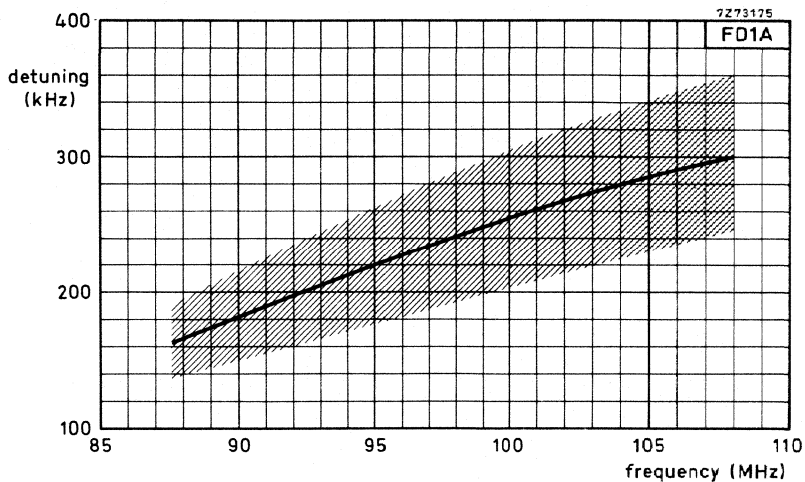

Fig. 6 Detuning as a function of signal frequency at a control voltage change from 0 to +400 mV.

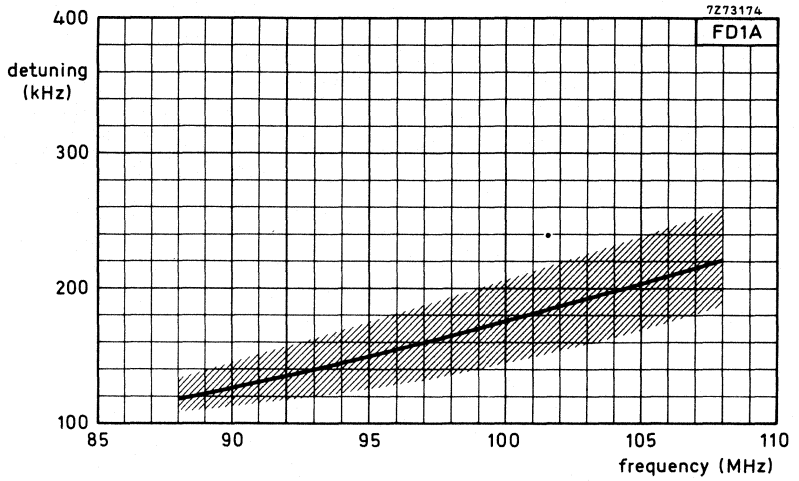

Fig. 7 Detuning as a function of signal frequency at a control voltage change from 0 to -400 mV.

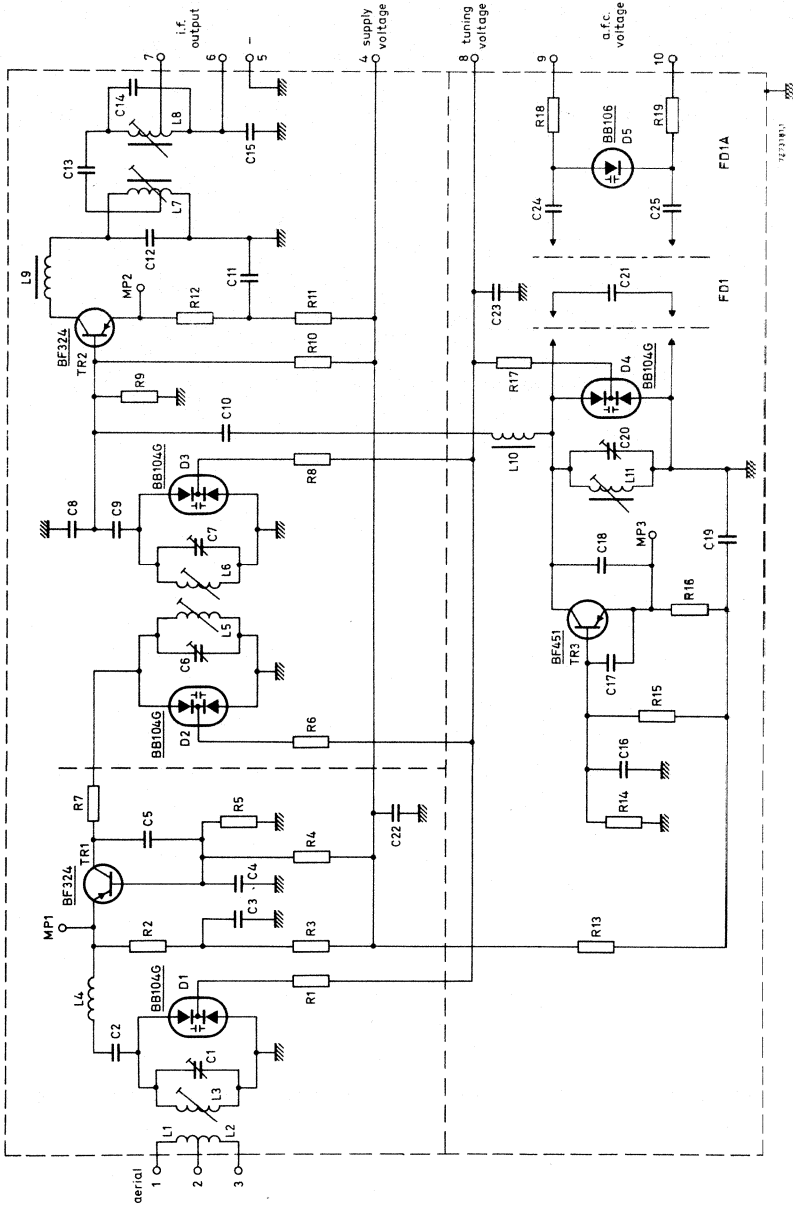

Fig. 8.





F.M. TUNER

- With diode tuning
- For European and American band
- With automatic frequency control
- Suited for digital tuning systems

QUICK REFERENCE DATA

Supply voltage (d.c.)	12 V
Frequency range	87,5 to 108 MHz
Intermediate frequency	10,7 MHz

APPLICATION

This f.m. tuner is designed for use in hi-fi radio receivers. An output voltage from the local oscillator is made available for driving digital frequency displays and tuning systems. Apart from this the tuner is compatible with tuner FD1A.

DESCRIPTION

The FD1B is an f.m. tuner with electronic tuning, covering the v.h.f. band II (frequency range 87,5 to 108 MHz).

Mechanically the tuner is built on a low-loss printed board, carrying all components, in a metal housing of a rectangular frame, and front and rear cover (Fig. 2). All contacts are on a board edge at the underside, which can be inserted into a mounting socket, facilitating set repair. Connections to the tuner can also be directly soldered to the contacts.

The tuner has a coaxial socket at the side of the frame for coupling out the oscillator sample.

The tuner is equipped with silicon transistors and silicon variable capacitance diodes.

The aerial signal is fed via an input filter to the r.f. amplifier stage, which is equipped with a high-current transistor BF324 operating in common base mode. Due to the high operating current of this transistor its gain is so high that the coupling to the tuned input circuit can be loose, resulting in good signal handling capability, low noise and good repeat-spot suppression. At the output the r.f. amplifier is provided with a tunable band-pass filter, whose secondary circuit is loosely coupled via capacitors to the base of mixer transistor BF324, operating in common emitter mode, contributing to good signal handling capability of the mixer stage. The oscillator is equipped with a transistor BF451 in common base mode and coupled to the mixer via a low-pass filter, which effectively suppresses harmonics of the oscillator frequency.

The a.f.c. circuit is provided with variable capacitance diode BB106, which controls the oscillator frequency directly.



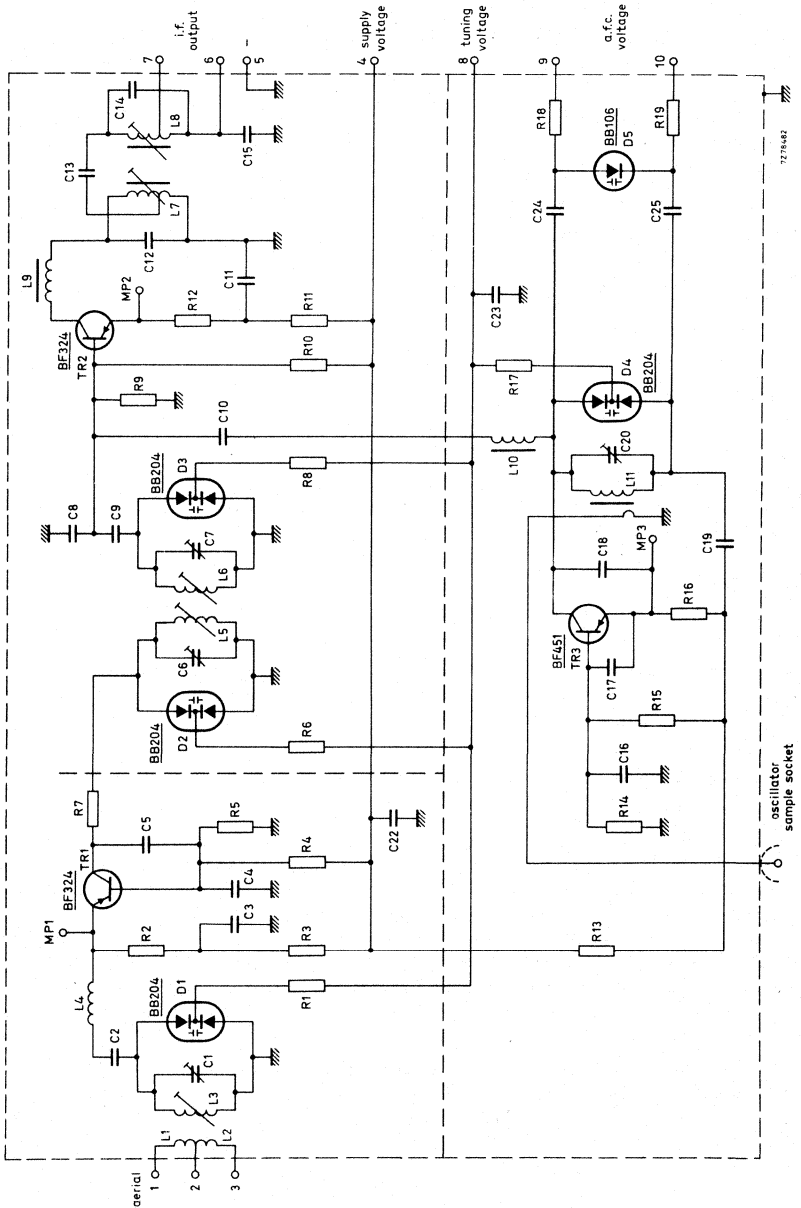

Fig. 1.

MECHANICAL DATA

Dimensions in mm

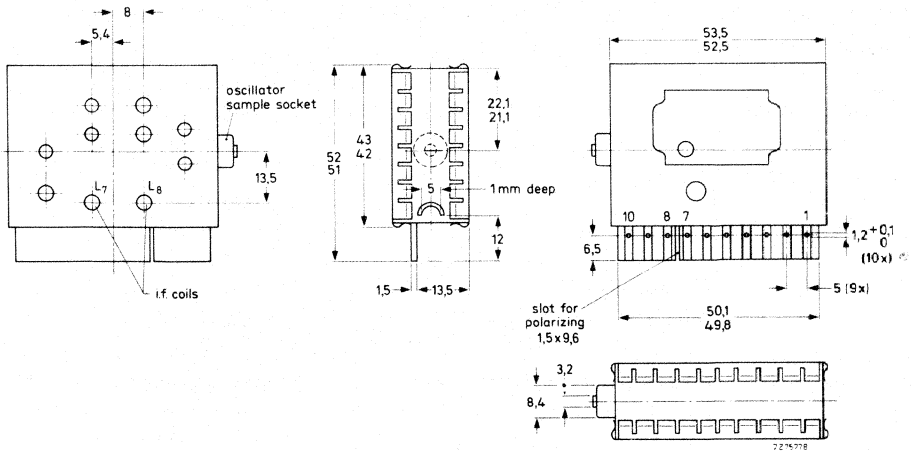

Fig. 2.

- Terminals 1 and 2 = aerial, 75 Ω , asymmetrical
 1 and 3 = aerial, 300 Ω , symmetrical
 4 = supply voltage, +12 V
 5 = earth
 6 and 7 = i.f. output
 8 = tuning voltage, +3,8 to +28 V
 9 and 10 = a.f.c. voltage

Mounting

The tuner can be inserted into a mounting socket* or soldered directly to a printed board. The tuner may be mounted anywhere in the receiver and there are no restrictions on orientation.

For connection to the oscillator sample socket a coaxial plug has to be used; type 3/2-50 (manufacturer: Daut und Rietz) is recommended.

Marking

The f.m. tuners are marked with the type number, the 12-digit catalogue number, and the production code.

* Type 3/6 – 178.01 or type 3/6 – 178.02 (manufacturer: Daut und Rietz) is recommended.

ELECTRICAL DATA

Unless otherwise specified all electrical values apply at an ambient temperature of 25 °C, a relative humidity of $60 \pm 15\%$, a supply voltage of 12 V and a signal frequency of 98 MHz.

Semiconductors

r.f. amplifier	BF324
mixer	BF324
oscillator	BF451
tuning diodes	4 x BB204; 1 x BB106

Ambient temperature range

operating	0 to +50 °C
storage	-20 to +60 °C

Supply voltage (d.c.)+12 \pm 1 V**Current drawn from +12 V supply**

max. 10 mA; typ. 9 mA

Tuning voltage range (Fig. 3)

+3,8 to +28 V

Frequency range

87,5 to 108 MHz

Intermediate frequency10,7 MHz \pm 30 kHz

The oscillator frequency is higher than the signal frequency

I.F. bandwidth (3 dB)270 \pm 30 kHz

Fig. 3 Tuning voltage as a function of signal frequency.

Input impedance	
asymmetrical	75 Ω
symmetrical	300 Ω
Output impedance	470 Ω
Gain	min. 27 dB; typ. 30 dB
Noise figure	max. 7,5 dB; typ. 6,5 dB
Reflection factor	max. 0,5; typ. 0,35
I.F. suppression	min. 76 dB; typ. 83 dB
Image rejection	min. 64 dB; typ. 72 dB
Repeat spot suppression (RSS)* (Fig. 4)	min. 70 dB; typ. 82 dB
Double beat suppression (DBS)** (Fig. 4)	
DBS ₁	min. 70 dB; typ. 80 dB
DBS ₂	min. 64 dB; typ. 75 dB
DBS ₃	min. 64 dB; typ. 72 dB
Continuous beat suppression (CBS) [▲] (Fig. 5)	min. 56 dB; typ. 62 dB
Minimum input signal (e.m.f.) producing a shift of the oscillator frequency of 20 kHz (75 Ω input impedance)	1 V
Shift of oscillator frequency at a change of the supply voltage of 1 V	max. 30 kHz
Temperature coefficient of the oscillator	see Fig. 6
Oscillator radiation	according to VDE 0872.7 and 0872.8
A.F.C. sensitivity	see Figs 7 and 8
Oscillator sample voltage over 60 Ω	min. 15 mV; typ. 20 mV
Oscillator sample frequency	equal to oscillator frequency

* Suppression of a signal arising by conversion of harmonics of the oscillator signal and those of a strong aerial signal.

** Suppression of a signal arising from two strong aerial signals.

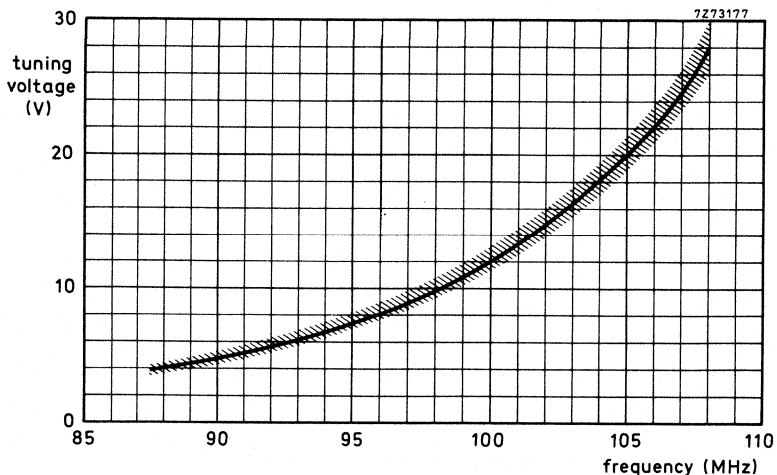
▲ Suppression of a signal arising from the harmonic of two strong aerial signals with a frequency difference equal to the intermediate frequency.

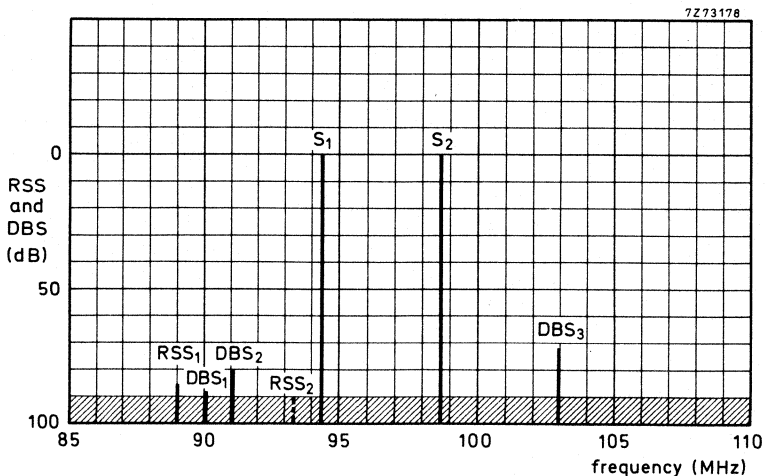

Fig. 4 Location of transmitter frequencies, repeat spots and double beats. Reference signals S1 and S2: 10 μ V.

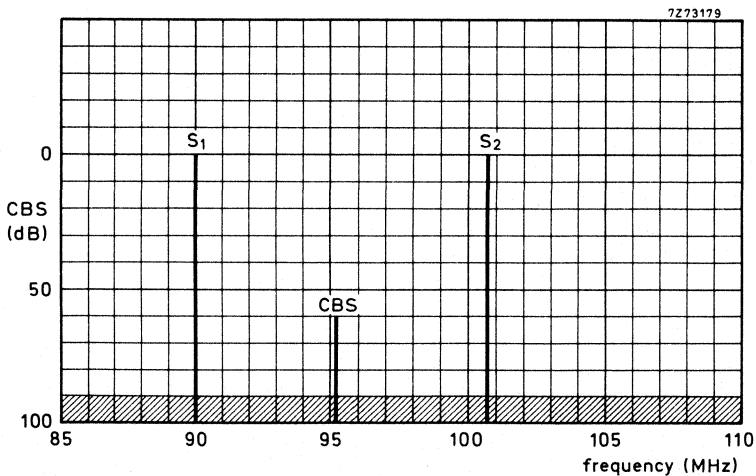

Fig. 5 Location of transmitter frequencies and measuring frequency for measuring the continuous beat suppression (CBS).

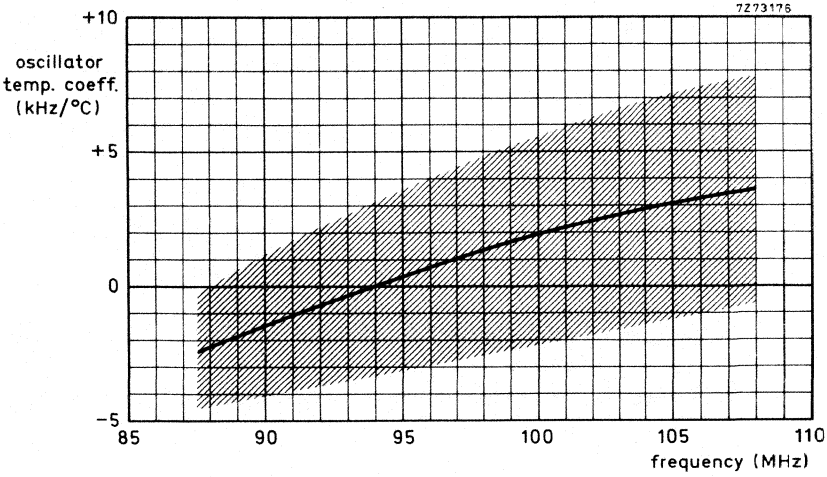

Fig. 6 Oscillator temperature coefficient as a function of signal frequency, measured in the temperature range 15 to 25 °C.

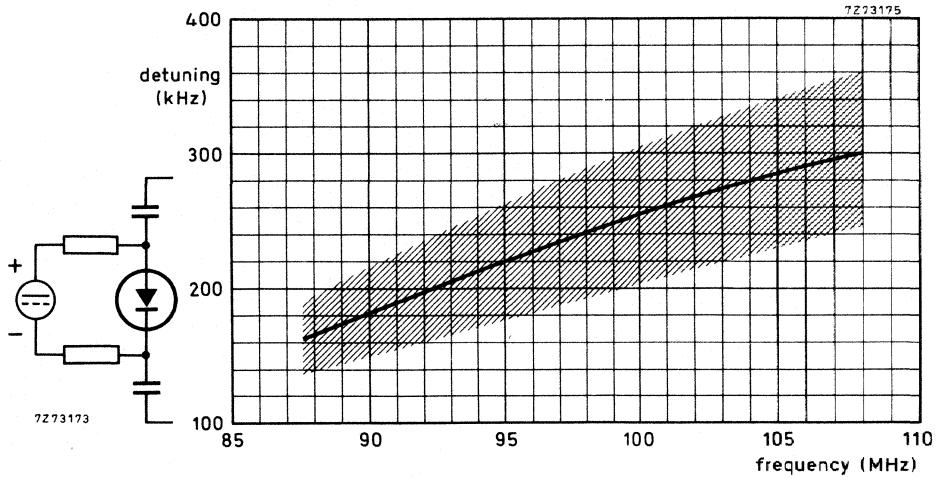

Fig. 7 Detuning as a function of signal frequency at a control voltage change from 0 to +400 mV.

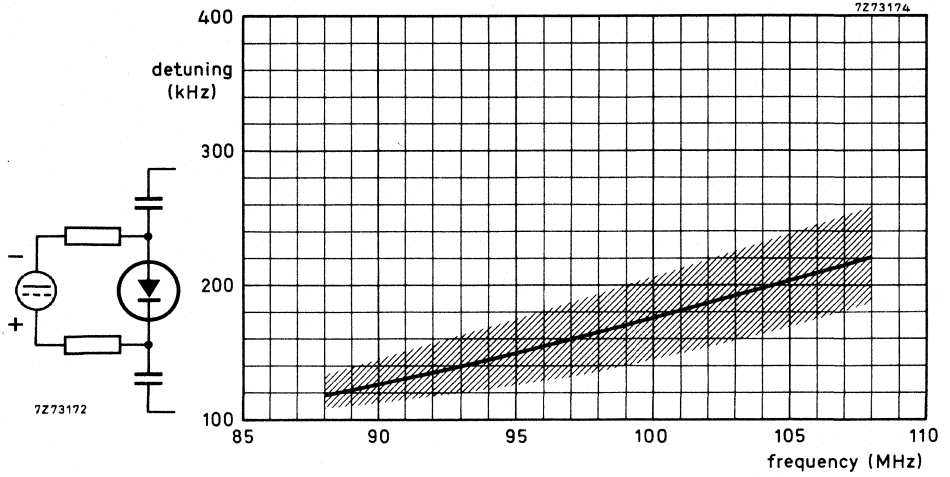

Fig. 8 Detuning as a function of signal frequency at a control voltage change from 0 to -400 mV.

Note: For aligning the i.f. coils, a screwdriver with dimensions as shown in Fig. 9 is recommended.

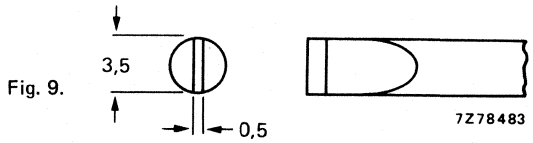

Fig. 9.

APPLICATION INFORMATION

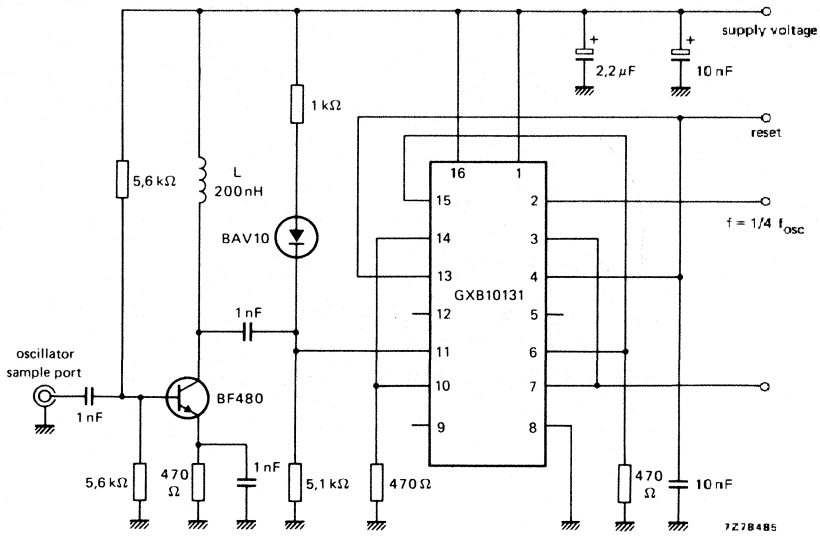

Fig. 10 Recommended circuit of a 4-to-1 divider with preamplifier for connection to the oscillator sample port.

F.M. TUNER

- With diode tuning
- For European and American band
- With automatic frequency control

QUICK REFERENCE DATA

Supply voltage (d.c.)	12 V
Frequency range	87,5 to 108 MHz
Intermediate frequency	10,7 MHz

APPLICATION

This f.m. tuner is designed for use in hi-fi radio receivers.

DESCRIPTION

The FD1B is an f.m. tuner with electronic tuning, covering the v.h.f. band II (frequency range 87,5 to 108 MHz).

Mechanically the tuner is built on a low-loss printed board, carrying all components, in a metal housing of a rectangular frame, and front and rear cover (Fig. 2). All contacts are on a board edge at the underside, which can be inserted into a mounting socket, facilitating set repair. Connections to the tuner can also be directly soldered to the contacts.

The tuner is equipped with silicon transistors and silicon variable capacitance diodes. Thanks to the application of high-current transistors, the tuner has sufficient large-signal properties within the whole frequency range.



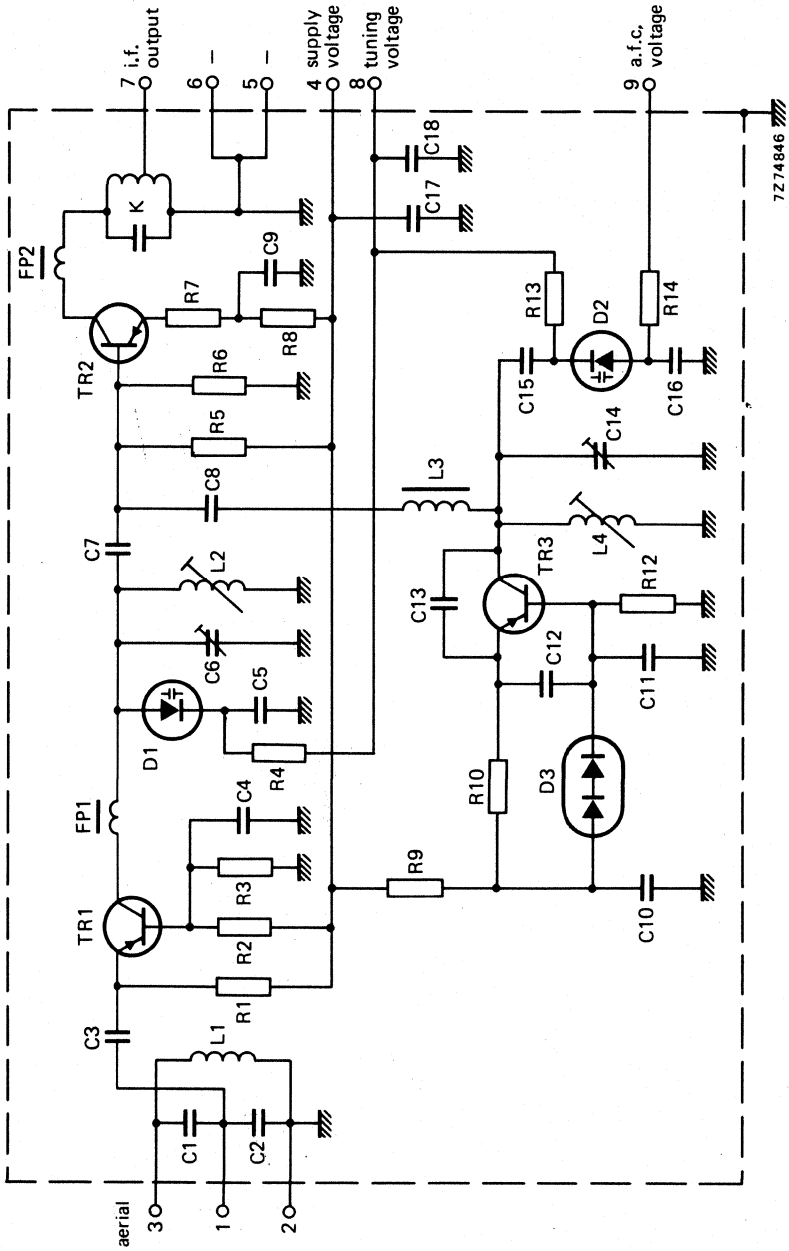

Fig. 1.

MECHANICAL DATA

Dimensions in mm

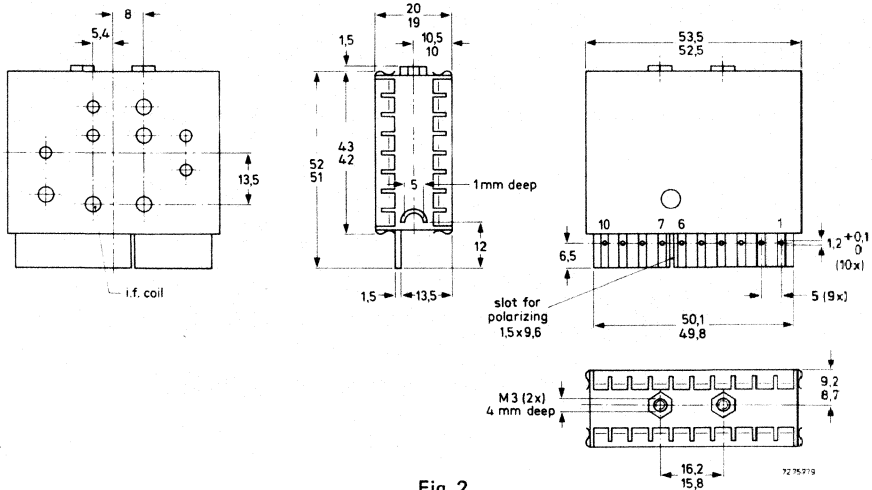

Fig. 2.

- Terminals 1 and 2 = aerial, 75Ω , asymmetrical
- 2 and 3 = aerial, 300Ω , symmetrical
- 4 = supply voltage, + 12 V
- 5 and 6 = earth
- 7 = i.f. output
- 8 = tuning voltage, + 2 to + 12 V
- 9 = a.f.c. voltage

Mounting

The tuner can be inserted into a mounting socket* or soldered directly to a printed board. The tuner may be mounted anywhere in the receiver and there are no restrictions on orientation.

Marking

The f.m. tuners are marked with the type number, the 12-digit catalogue number, and the production code.

* Type 3/6-178.03 for print connection or type 3/6-178.04 for solder connection (manufacturer: Daut und Rietz) is recommended.

ELECTRICAL DATA

Unless otherwise specified all electrical values apply at an ambient temperature of 25 °C, a relative humidity of $60 \pm 15\%$, a supply voltage of 12 V and a signal frequency of 98 MHz.

Semiconductors

r.f. amplifier	BF324
mixer	BF324
oscillator	BF451
tuning diodes	2 x BB110G

Ambient temperature range

operating	0 to +50 °C
storage	-20 to +60 °C

Supply voltage (d.c.)+ 12 \pm 1 V**Current drawn from + 12 V supply**6,4 \pm 0,5 mA**Tuning voltage range (Fig. 3)**

+ 2 to + 12 V

Frequency range

87,5 to 108 MHz

Intermediate frequency10,7 MHz \pm 30 kHz

The oscillator frequency is higher than the signal frequency

I.F. bandwidth (3 dB)230 \pm 60 kHz

Fig. 3 Tuning voltage as a function of signal frequency.

Input impedance	
asymmetrical	75 Ω
symmetrical	300 Ω
Output impedance	470 Ω
Gain at 89 and 102 MHz	min. 34 dB; typ. 38 dB
Noise figure	max. 7,5 dB; typ. 4 dB
I.F. suppression	52 dB
Image rejection	min. 26 dB; typ. 30 dB
Minimum input signal (e.m.f.) producing a shift of the oscillator frequency of 20 kHz (75 Ω input impedance)	1 V
Shift of oscillator frequency at a change of the supply voltage of 1 V	max. 30 kHz
Temperature coefficient of the oscillator	max. 7 kHz/ $^{\circ}$ C; typ. 3 kHz/ $^{\circ}$ C
Oscillator radiation	according to VDE 0872.7 and 0872.8
A.F.C. sensitivity	see Fig. 4

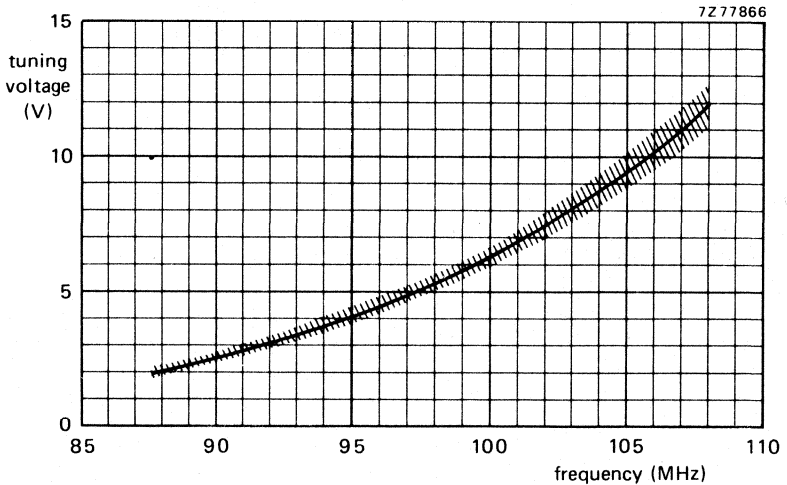
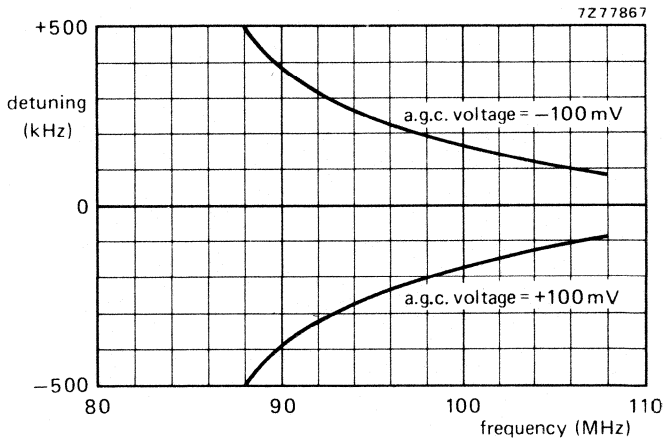

Fig. 4 Detuning as a function of signal frequency.

Note: For aligning the i.f. coil, a screwdriver with dimensions as shown in Fig. 5 is recommended.

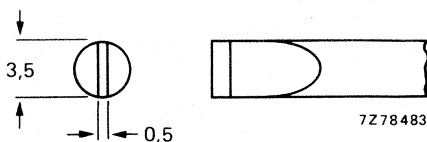

Fig. 5.

F.M. TUNER

- With diode tuning
- For European and American band
- With automatic frequency control

QUICK REFERENCE DATA

Supply voltage (d.c.)	12 V
Frequency range	87,5 to 108 MHz
Intermediate frequency	10,7 MHz

APPLICATION

This f.m. tuner is designed for use in hi-fi radio receivers. The tuner is compatible with tuner FD1A.

DESCRIPTION

The FD1F is an f.m. tuner with electronic tuning, covering the v.h.f. band II (frequency range 87,5 to 108 MHz).

Mechanically the tuner is built on a low-loss printed board, carrying all components, in a metal housing of a rectangular frame, and front and rear cover (Fig. 2). All contacts are on a board edge at the underside, which can be inserted into a mounting socket, facilitating set repair. Connections to the tuner can also be directly soldered to the contacts.

The tuner is equipped with silicon transistors and silicon variable capacitance diodes.

The aerial signal is fed via a tuned input filter to the r.f. amplifier stage, which is equipped with a dual-gate MOS field-effect transistor BF900. Due to the properties of this transistor its gain is so high that the coupling to the tuned input circuit can be loose, resulting in good signal handling capability, low noise and good repeat-spot suppression. At the output the r.f. amplifier is provided with a tunable band-pass filter, whose secondary circuit is loosely coupled via capacitors to the base of mixer transistor BF324, operating in common emitter mode, contributing to good signal handling capability of the mixer stage. The oscillator is equipped with a transistor BF936 in common base mode and coupled to the mixer via a low-pass filter, which effectively suppresses harmonics of the oscillator frequency.

The a.f.c. circuit is provided with variable capacitance diode BB106, which controls the oscillator frequency directly.



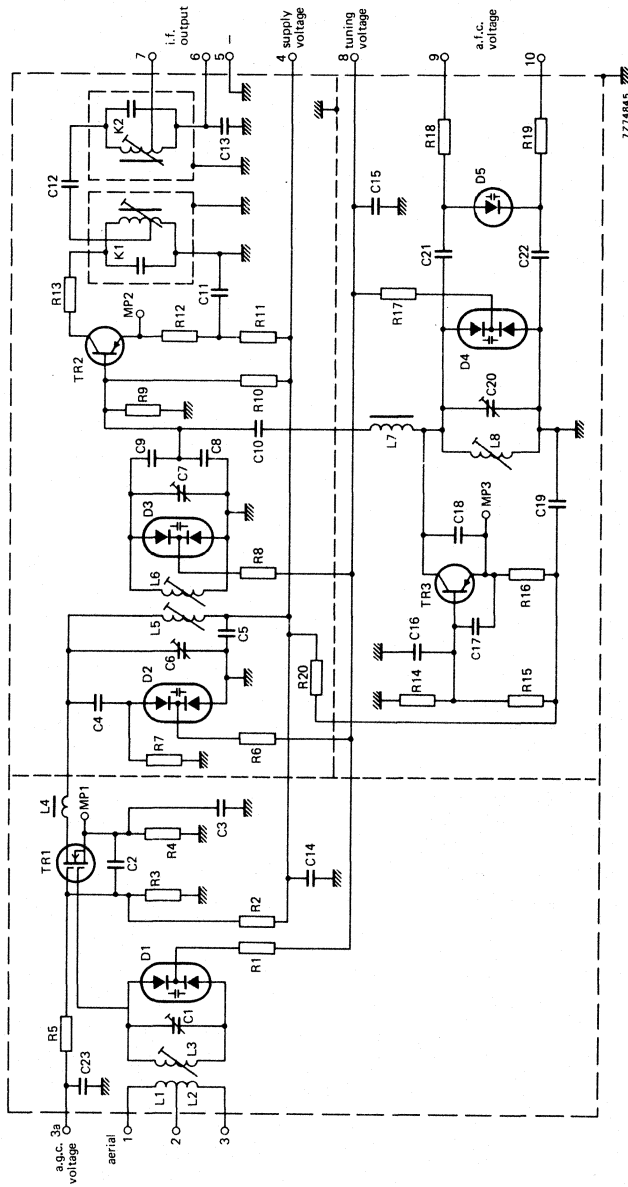

Fig. 1.



MECHANICAL DATA

Dimensions in mm

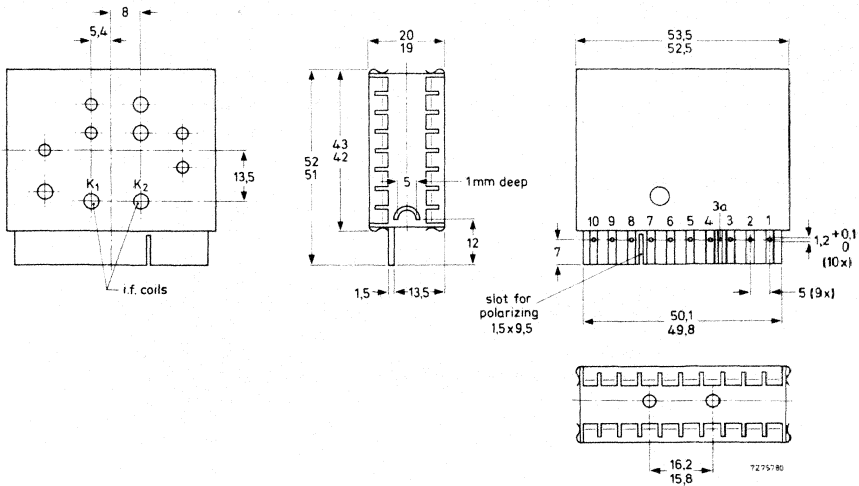

Fig. 2.

- Terminals 1 and 2 = aerial, 75 Ω , asymmetrical
 1 and 3 = aerial, 300 Ω , symmetrical
 3a = a.g.c. voltage, + 4,5 to -4 V
 4 = supply voltage, + 12 V
 5 = earth
 6 and 7 = i.f. output
 8 = tuning voltage, + 3,8 to + 28 V
 9 and 10 = a.f.c. voltage

Mounting

The tuner can be inserted into a mounting socket * or soldered directly to a printed board. The tuner may be mounted anywhere in the receiver and there are no restrictions on orientation.

Marking

The f.m. tuners are marked with the type number, the 12-digit catalogue number, and the production code.

* Type 3/6-178.05 for print connection or type 3/6-178.06 for solder connection (manufacturer: Daut und Rietz) is recommended.

ELECTRICAL DATA

Unless otherwise specified all electrical values apply at an ambient temperature of 25 °C, a relative humidity of $60 \pm 15\%$, a supply voltage of 12 V and a signal frequency of 98 MHz.

Semiconductors

r.f. amplifier	BF900
mixer	BF324
oscillator	BF936
tuning diodes	4 x BB204; 1 x BB106

Ambient temperature range

operating	0 to +50 °C
storage	-20 to +60 °C

Supply voltage (d.c.)

+12 ± 1 V

Current drawn from +12 V supply

typ. 10 mA

Tuning voltage range (Fig. 3)

+3,8 to +28 V

Frequency range

87,5 to 108 MHz

Intermediate frequency

10,7 MHz ± 30 kHz

The oscillator frequency is higher than the signal frequency

I.F. bandwidth (3 dB)

280 ± 30 kHz

A.G.C. voltage

+4,5 to -4 V

A.G.C. range

min. 45 dB; typ. 50 dB

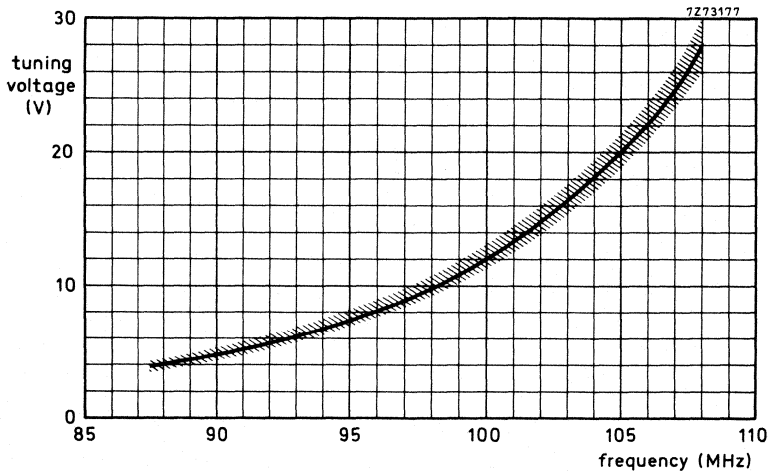

Fig. 3 Tuning voltage as a function of signal frequency.

Input impedance	
asymmetrical	75 Ω
symmetrical	300 Ω
Output impedance	470 Ω
Gain at 89 and 102 MHz	min. 30 dB; typ. 35 dB
Noise figure	max. 6,5 dB; typ. 5 dB
Reflection factor	max. 0,5; typ. 0,35
I.F. suppression	min. 82 dB; typ. 90 dB
Image rejection	min. 74 dB; typ. 84 dB
Repeat spot suppression (RSS) *	min. 70 dB; typ. 82 dB
Double beat suppression (DBS) **	
DBS ₁	min. 70 dB; typ. 80 dB
DBS ₂	min. 64 dB; typ. 75 dB
DBS ₃	min. 64 dB; typ. 72 dB
Continuous beat suppression (CBS) ▲	min. 56 dB; typ. 62 dB
Minimum input signal (e.m.f.) producing a shift of the oscillator frequency of 20 kHz (75 Ω input impedance)	1 V
Shift of oscillator frequency at a change of the supply voltage of 1 V	max. 30 kHz
Drift of oscillator frequency 30 s after switching on	max. 15 kHz
Temperature coefficient of the oscillator	see Fig. 4
Oscillator radiation	according to VDE 0872/7.72 and C.I.S.P.R. 24/3 (1970)
A.F.C. sensitivity	see Figs 5 and 6



* Suppression of a signal arising by conversion of harmonics of the oscillator signal and those of a strong aerial signal.

** Suppression of a signal arising from two strong aerial signals.

▲ Suppression of a signal arising from the harmonic of two strong aerial signals with a frequency difference equal to the intermediate frequency.

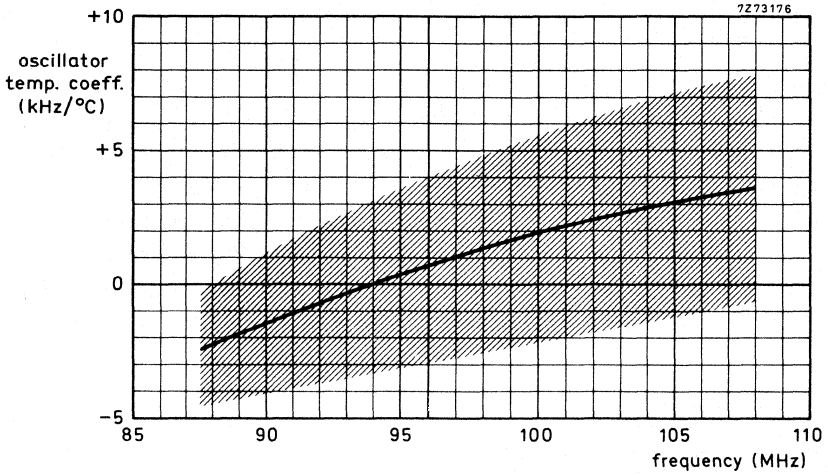

Fig. 4 Oscillator temperature coefficient as a function of signal frequency, measured in the temperature range 15 to 25 °C.

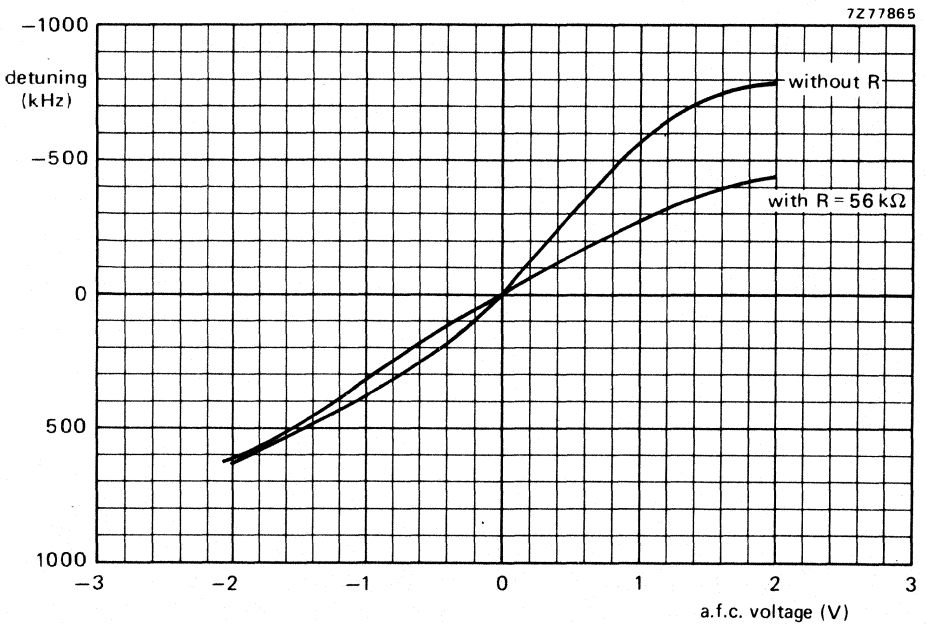

Fig. 5 Detuning as a function of a.f.c. voltage, measured with the measuring circuit shown in Fig. 6.

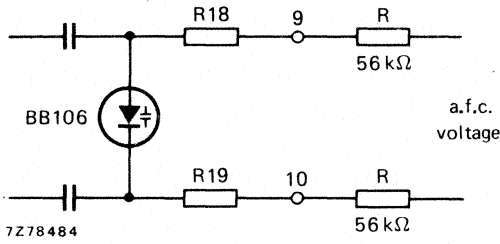

Fig. 6 Circuit for measuring the detuning as a function of a.f.c. voltage.

Note: For aligning the i.f. coils a screwdriver with dimensions as shown in Fig. 7 is recommended.

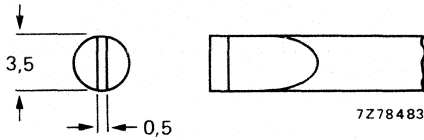

Fig. 7.



F.M. TUNERS

- With diode tuning
- For European and American band
- Suited for digital tuning systems

QUICK REFERENCE DATA

Supply voltages (d.c.)	5 V, 20 V and 30 V
Frequency range	87,5 to 108 MHz
Intermediate frequency	10,7 MHz

APPLICATION

The f.m. tuners FD11 and FD11K are designed for use in high-quality, hi-fi radio receivers.

In the FD11 an output voltage from the local oscillator is made available for driving digital frequency displays and tuning systems. Apart from this both tuners are identical.



DESCRIPTION

The FD11 and FD11K are f.m. tuners with electronic tuning, covering the v.h.f. band II (frequency range 87,5 to 108 MHz).

Mechanically the tuners are built on a low-loss printed board, carrying all components, in a metal housing of a rectangular frame, and front and rear cover. (Fig. 2). All contacts are on a board edge at the bottom, which can be inserted into a mounting socket, facilitating set repair. Connections to the tuner can also be directly soldered to the contacts.

The tuners are equipped with silicon semiconductors. The aerial signal is fed via a double-tuned input filter to the r.f. amplifier stage. This stage is equipped with a dual-gate MOS field-effect transistor BF900, the gain of which can be controlled by an a.g.c. voltage. At the output the r.f. amplifier is provided with a double-tuned band filter, transferring the signal to the mixer stage, which is built-up with the integrated circuit TCA240. At the output the mixer has a 10,7 MHz band filter (L8, K1), which can be aligned if adaptation to the receiver is necessary.

The oscillator is equipped with a transistor BF451. The stability of the oscillator frequency has been increased to a high degree by special means. The influence of supply voltage variations has been reduced by a separate stabilizing of the oscillator supply, while temperature influences on coils, transistors, board material and trimmers are compensated by the careful choice of the temperature coefficients of the capacitors of the tuned circuit and of the feedback capacitors. Moreover the influence of drift of the capacitance diodes is compensated by travelling the tuning-voltage signal via an emitter follower. By loosely coupling the oscillator to the mixer, the pulling is very small.

A rectifier circuit, which is connected to the secondary of the i.f. output filter, provides an internal a.g.c. (terminals 1 and 7 interconnected). If in the case of weak signal reception, the controlling is disturbed by neighbouring carriers, the a.g.c. can be switched off, or be provided by an external a.g.c. voltage, generated in the receiver. Without a.g.c. the power gain is maximum.

The oscillator signal is brought to ECL level via a transistor BF199. The frequency (f_0) is changed to $f_0/4$ by a 4 : 1 divider (GXB10131). The sample signal, which is coupled out symmetrically, can be applied to standard circuits for digital frequency display without any difficulty. By means of a signal to the reset input the divider can be stopped (terminals 17 and 18 on the same potential).

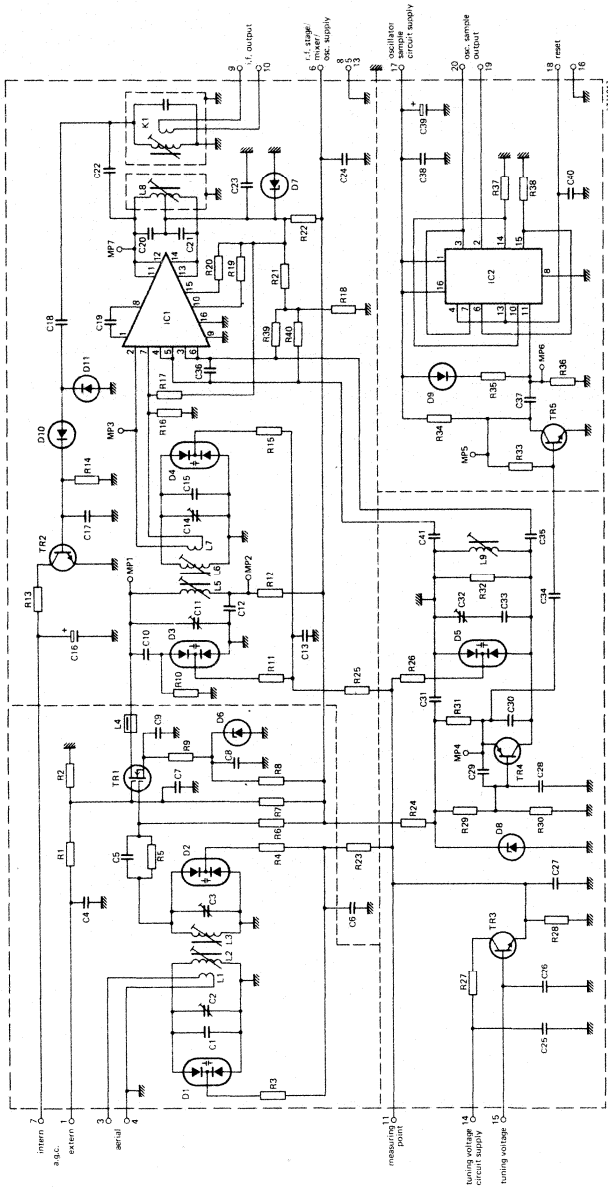

Fig. 1.



MECHANICAL DATA

Dimensions in mm

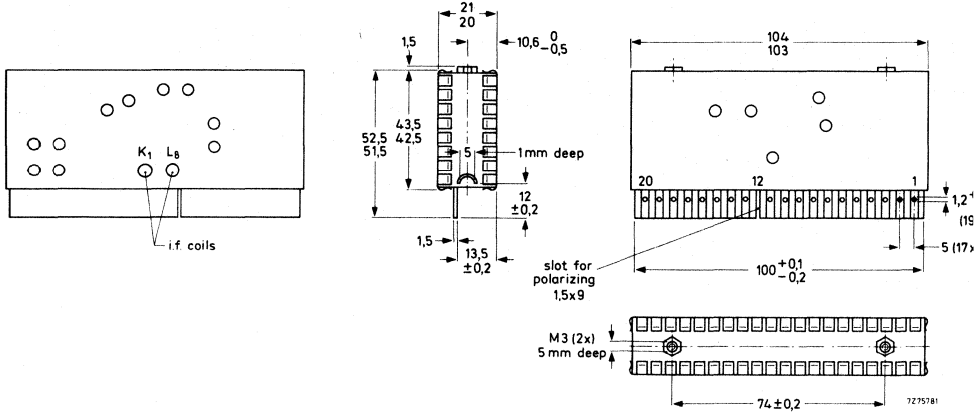

Fig. 2.

- Terminals: 1 = a.g.c. voltage, 10 to 0 V
 3 and 4 = aerial, 75 Ω
 5, 8, 13, 16 = earth
 6 = r.f. stage, mixer and oscillator supply
 7 = internal a.g.c. voltage
 9 and 10 = i.f. output
 14 = tuning voltage circuit supply
 15 = tuning voltage, + 3,8 to + 27 V
 17 = oscillator sample circuit supply
 18 = reset
 19 and 20 = oscillator sample output
 11 = measuring point

Mounting

The tuner can be inserted into a mounting socket or soldered directly to a printed board. It can be fitted by means of two screws M3. The tuner may be mounted anywhere in the receiver and there are no restrictions on orientation.

Marking

The f.m. tuners are marked with the type number, the 12-digit catalogue number and the production code.

ELECTRICAL DATA

Unless otherwise specified all electrical values apply at an ambient temperature from 20 to 25 °C, a relative humidity of 60 ± 15% and supply voltages as given below.

Semiconductors	BF451, BC547B, BC548C, BF199, BF900, 3 x BAV10, 2 x BZX79-C12, BZX79-C5V1, 4 x BB204B, BB204G
Ambient temperature range	
operating	+ 10 to + 50 °C
storage	-25 to + 60 °C
Supply voltage (d.c.)	
r.f. amplifier, mixer and oscillator	+ 20 ± 1 V
tuning circuit	+ 30 ± 1 V
oscillator sample circuit	+ 5 ± 0,25 V
Current drawn from	
r.f. amplifier, mixer and	
oscillator supply	22 to 32 mA
tuning circuit supply	0,15 to 1,4 mA
oscillator sample circuit supply	80 mA*
Tuning voltage range (Fig. 3)	+ 3,8 to + 27 V
Frequency range	87,5 to 108 MHz
Intermediate frequency	10,7 MHz ± 30 kHz The oscillator frequency is higher than the signal frequency

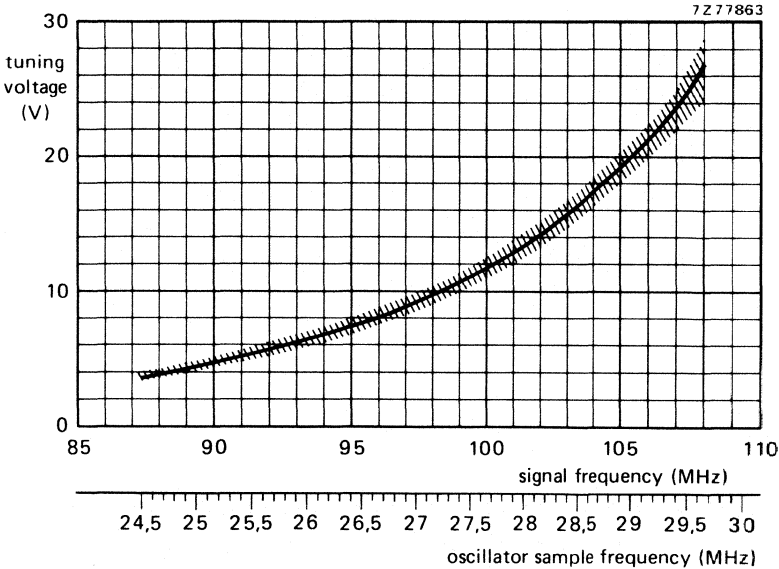

Fig. 3 Tuning voltage as a function of signal frequency.

* Terminals 19 and 20 each connected via a 470 Ω resistor to terminal 16 (earth).

I.F. bandwidth (3 dB)	300 ± 30 kHz
Tuning range of i.f. filter	± 100 kHz
Input impedance, asymmetrical	75 Ω
Output impedance	330 Ω
Gain	min. 36 dB; typ. 40 dB
Noise figure	max. 6 dB; typ. 4,8 dB
Reflection factor	max. 0,3
A.G.C. voltage	10 to 0 V
A.G.C. current	100 to 0 μA
A.G.C. range	50 dB
Minimum input signal for internal a.g.c.	65 dB (μV)
I.F. suppression	100 dB
Image rejection	min. 90 dB
Repeat spot suppression* (RSS, Fig. 4)	min. 100 dB
Double beat suppression** (Fig. 4)	
DBS1	80 dB
DBS2	100 dB
DBS3	80 dB
Continuous beat suppression▲ (CBS)	min. 100 dB
Pulling	
Input signal of tuned frequency producing a shift of the oscillator frequency of 5 kHz	min. 120 dB (μV)
Shift of oscillator frequency at a change of the supply voltage of 1 V	max. 5 kHz
Drift of oscillator frequency at a change of the ambient temperature from + 15 to + 35 °C 30 s after switching on	max. 2 kHz/°C max. 15 kHz
Oscillator radiation	according to CISPR 24/3 and VDE 0872/7.72
Oscillator sample voltage over 470 Ω	650 mV (p-p)
Oscillator sample frequency	¼ of oscillator frequency

* Suppression of a signal arising by conversion of harmonics of the oscillator signal and those of a strong aerial signal; reference level 14 dB (μV).

** Suppression of a signal arising from two strong aerial signals; reference level 14 dB (μV).

▲ Suppression of a signal arising from the harmonic of two strong aerial signals with a frequency difference equal to the intermediate frequency; reference level 14 dB (μV).

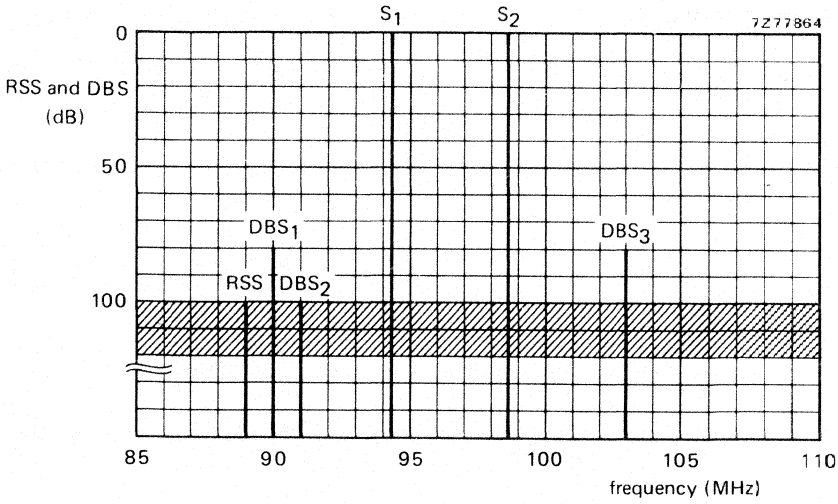

Fig. 4 Location of transmitter frequencies, repeat spots and double beats.

Note: For aligning the i.f. coils, a screwdriver with dimensions as shown in Fig. 5 is recommended.

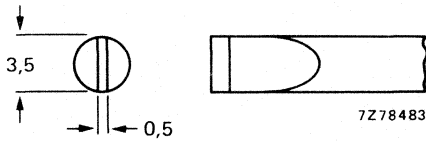

Fig. 5.

APPLICATION INFORMATION

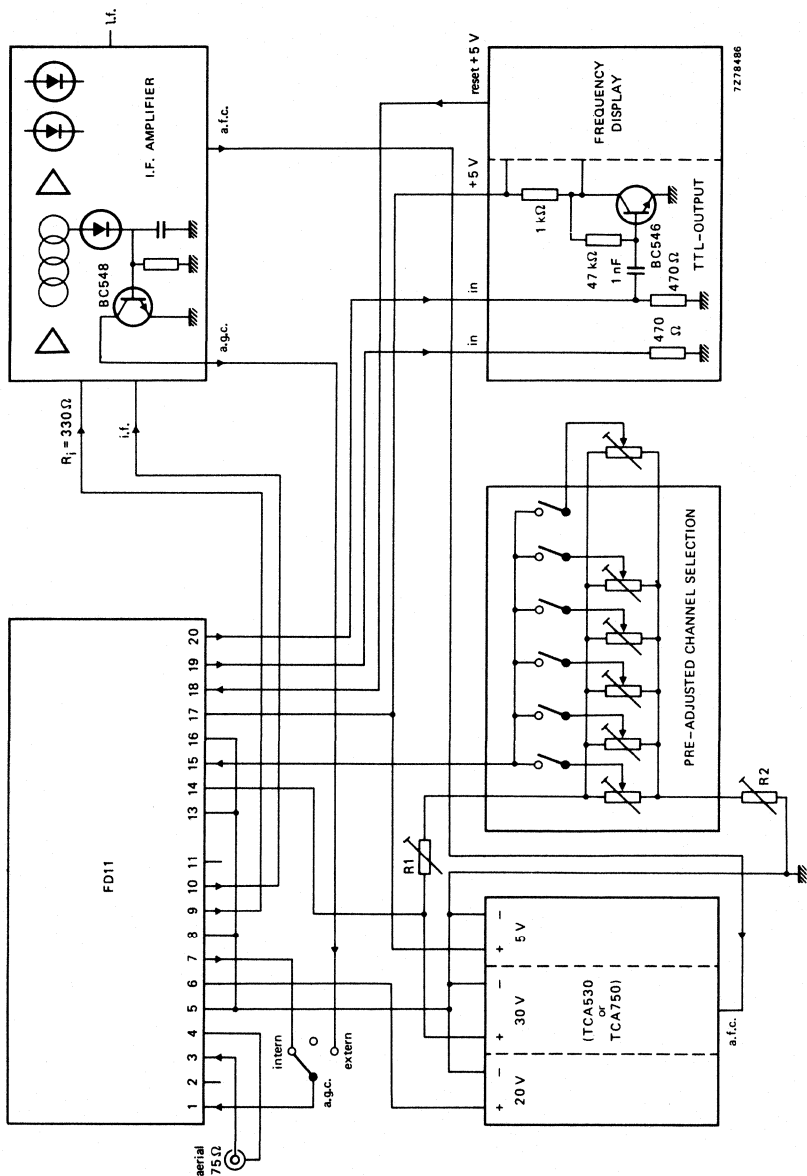

Fig. 6 Application example for FD11 with digital frequency display. The built-in 4 : 1 divider applies the oscillator sample signal on ECL level; a simple circuit with a transistor BC546 converts it to TTL level. Connections should be symmetrically to avoid radiation. The limits of the frequency range are adjusted with resistors R1 and R2.

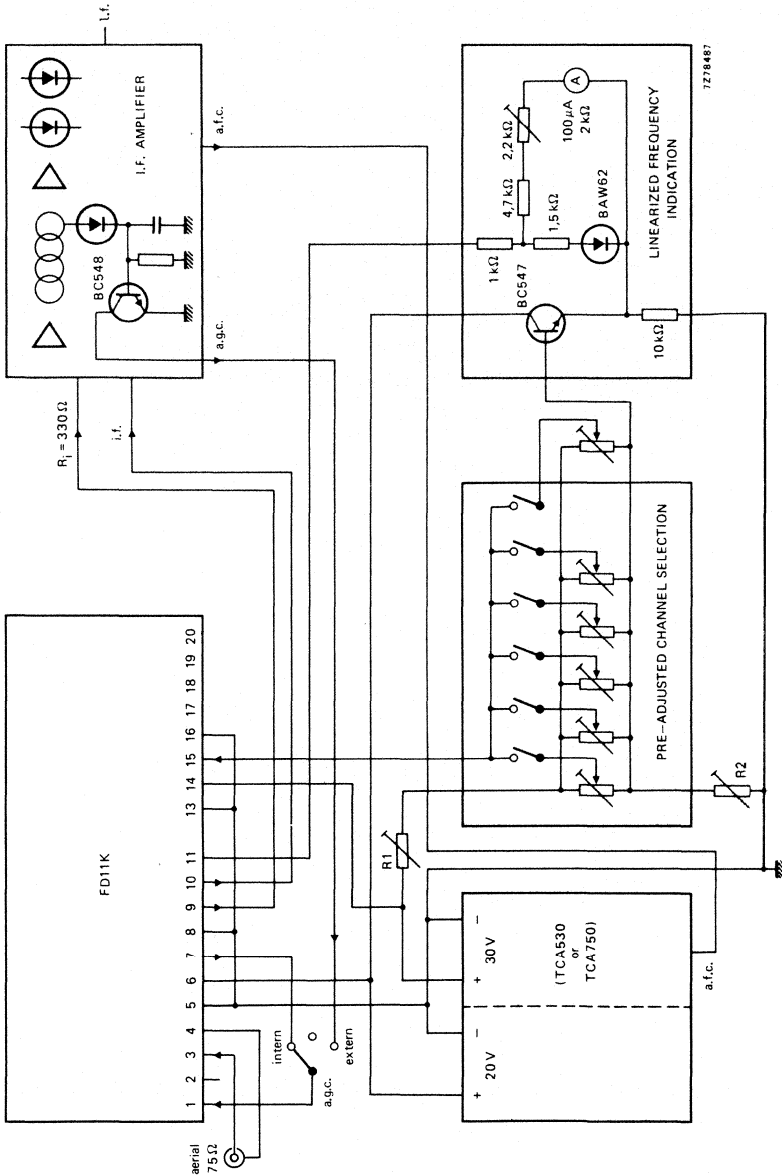

Fig. 7 Application example for FD11K with analogue frequency indication. The linearizing circuit with transistor BC547 and diode BAW62 adapts the oscillator signal to the indicating instrument. With this circuit the specified values for the drift of the oscillator frequency could be exceeded.



**Television tuners
and aerial input assemblies**



V.H.F. TELEVISION TUNER

with diode tuning

QUICK REFERENCE DATA

Systems	C. C. I. R. systems A, B and I		
	<u>system A</u>	<u>system B</u>	<u>system I</u>
Channels			
band I	B1 to B5	E2 to E4	IA to IC
band III	B6 to B14	E5 to E12	ID to IJ
Intermediate frequencies			
picture	34,65 MHz	38,9 MHz	39,5 MHz
sound	38,15 MHz	33,4 MHz	33,5 MHz

APPLICATION

Designed to cover 405 line v.h.f. and 625 line (wired distribution) channels, and the v.h.f. channels of C. C. I. R. system B.



DESCRIPTION

The ELC1042/05 is a v.h.f. tuner with electronic tuning and band switching, covering the v.h.f. band I (frequency range 41,5 to 68 MHz), and the v.h.f. band III (frequency range 174 to 230 MHz).

Mechanically the tuner is built on a low-loss printed-wiring board, carrying all components in a metal housing made of a rectangular frame and front and rear cover (see Fig.2). The aerial connection is on the frame side, all other connections (supply voltages, a.g.c. voltage, tuning and switching voltages) are made via feedthrough capacitors in the underside. The mounting method is shown in Figs.3 and 4.

The v.h.f. aerial signal is fed via an i.f. trap to a tuned input circuit, which is connected to the emitter of the input transistor BF264. The collector load of this transistor is formed by a double tuned circuit, transferring the signal to the base of the mixer transistor BF195. The oscillator is equipped with a BF194 transistor. The three r.f. circuits are tuned by three capacitance diodes BB105G. Switching between v.h.f. I and III is achieved by five switching diodes BA182.

The collector circuit of the mixer transistor is a single tuned i.f. resonant circuit, at the low end of which the i.f. signal is capacitively coupled out of the tuner.

The tuner requires transistor supply voltages of +12 V, a switching voltage of +12 V, a.g.c. voltages, variable from +2,5 V (normal operating point) to about +6 V (maximum a.g.c.) and a tuning voltage, variable from +0,3 V to +25 V.

The aerial input of the tuner is asymmetrical. For use in symmetrical aerial systems, aerial transformers (baluns) are available (see ACCESSORIES).

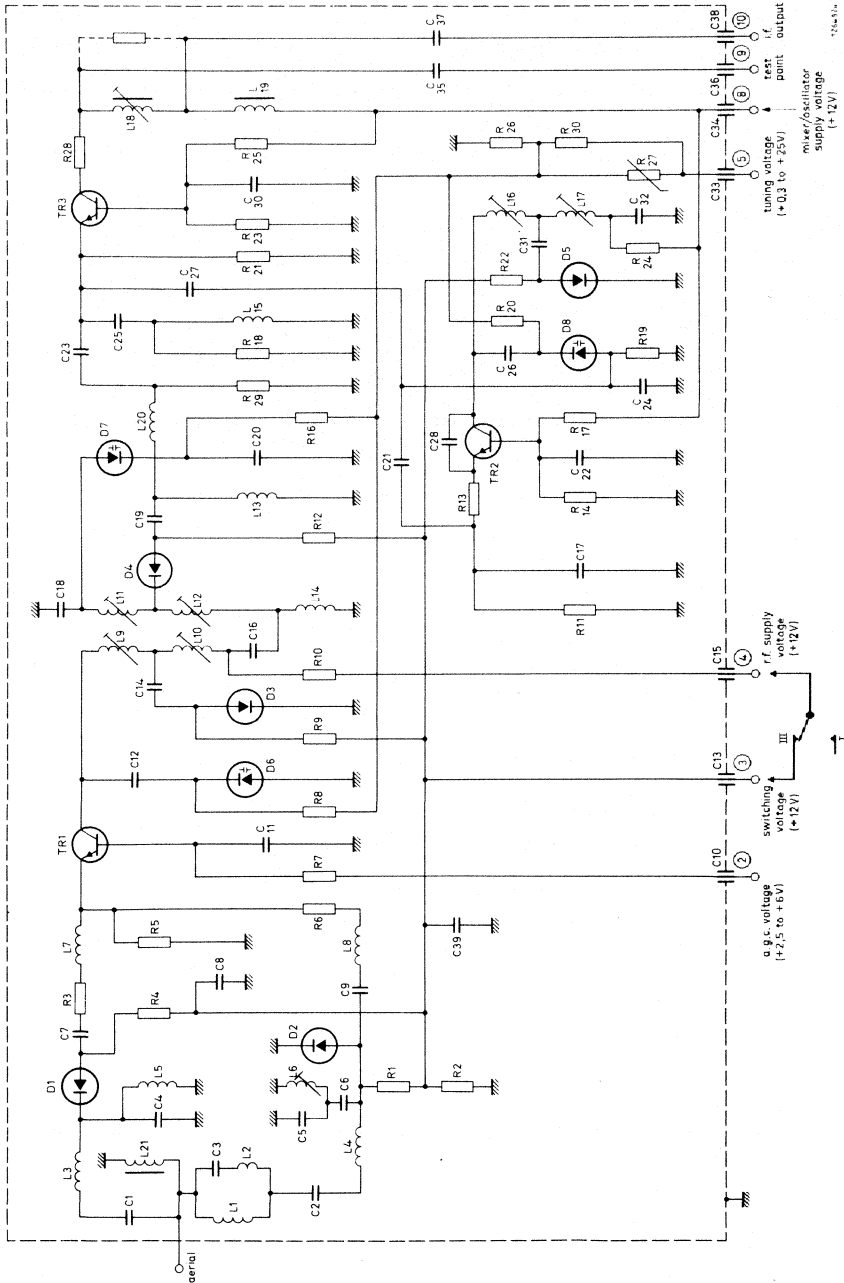
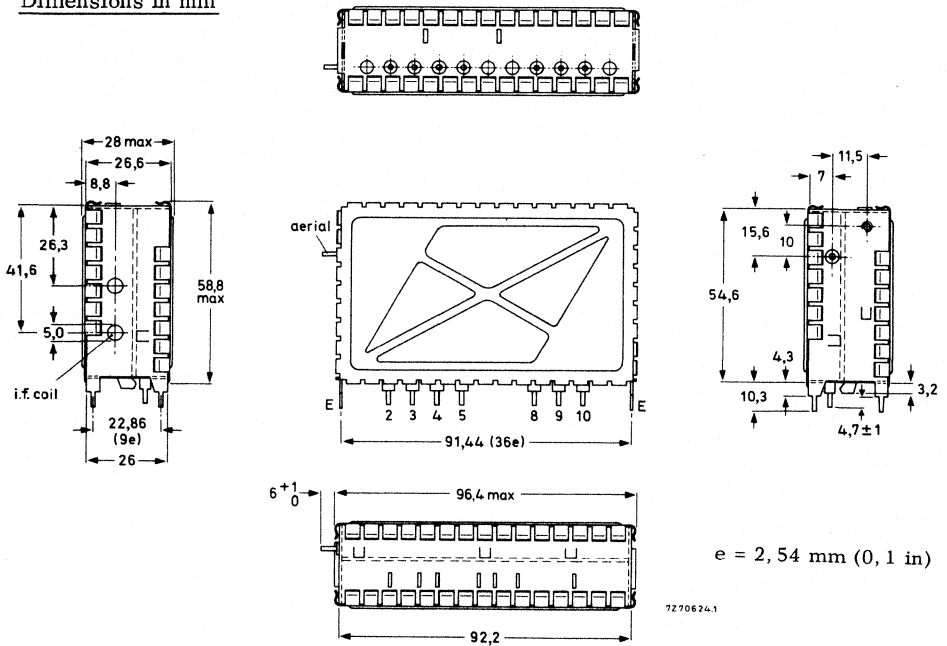

Fig. 1.



MECHANICAL DATA

Dimensions in mm



e = 2,54 mm (0,1 in)

Fig. 2

- Terminal 2 = a. g. c. voltage, +2,5 to +6,0 V
- 3 = switching voltage, v. h. f. III, +12 V (approx. 12,5 mA)
- 4 = r. f. supply voltage, +12 V (approx. 3,2 to 10 mA)
- 5 = tuning voltage, +0,3 to +25 V
- 8 = mixer/oscillator supply voltage, +12 V (approx. 6,7 mA)
- 9 = test point
- 10 = i. f. output
- E = earth

Mounting

The tuner may be mounted by soldering it on to a printed-wiring board, using the piercing diagram shown in Fig. 3. (The tuner may also be mounted by means of a snap-in mount or a bracket. Information will be supplied upon request).
The tuner may be mounted anywhere in the receiver and there are no restrictions on orientation.

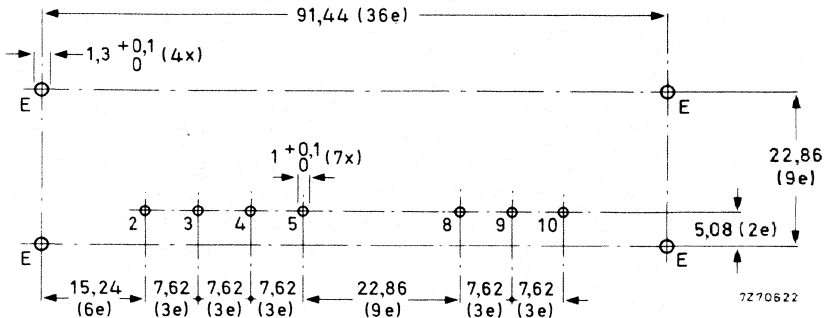

Fig. 3 Piercing diagram viewed from solder side of board; e = 2,54 mm (0,1 in)

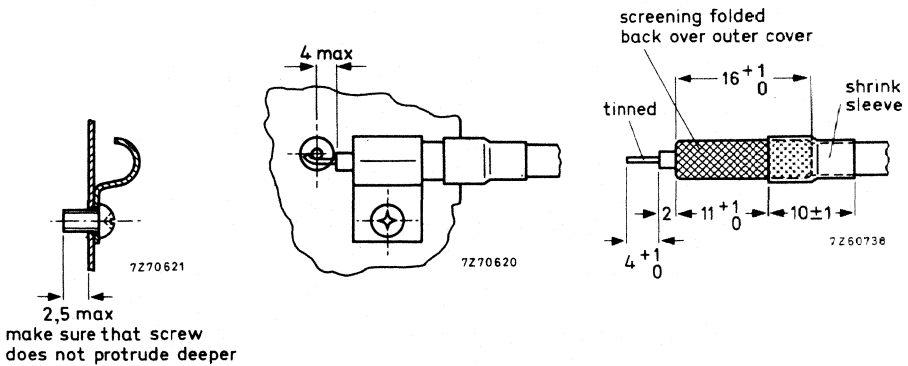

Fig. 4 Recommended fixing method of the aerial cable. Use a self-tapping screw.

ELECTRICAL DATA

Unless otherwise specified all electrical values apply at an ambient temperature of $25 \pm 5 \text{ }^\circ\text{C}$ and a supply voltage of $12 \pm 0,3 \text{ V}$.

Semiconductors, r.f. amplifier	BF264
mixer	BF195
oscillator	BF194
tuning diodes	3 x BB105G
switching diodes	5 x BA182
Ambient temperature range	
operating	+5 to +55 $^\circ\text{C}$
storage	-25 to +85 $^\circ\text{C}$
Supply voltage	+12 V \pm 10%
Current drawn from +12 V supply	
band I	10 to 16,5 mA
band III	22,5 to 29 mA
	} depending on a.g.c. voltage
A.G.C. voltage (Figs.5 and 6)	
band I, at nominal gain	+2,5 V
at 40 dB gain reduction	+4,9 V (typical)
band III, at nominal gain	+2,5 V
at 40 dB gain reduction	+4,3 V (typical)
A.G.C. current at 40 dB gain reduction	
band I	max. 0,8 mA
band III	max. 0,6 mA
Tuning voltage range (Figs. 7 and 8)	
Current drawn from 25 V tuning voltage supply	+0,3 to +25 V
	max. 30 μA
Switching voltage	
band I	open circuit
band III	+12 V, \pm 10%

Frequency ranges	<u>system A</u>	<u>system B</u>	<u>system I</u>
band I	channel B1 (picture carrier 45 MHz) to channel B5 (picture carrier 66,75 MHz)	channel E2 (p.c. 48,25 MHz) to channel E4 (p.c. 62,25 MHz)	channel IA (p.c. 45,75 MHz) to channel IC (p.c. 61,75 MHz)
band III	channel B6 (picture carrier 179,75 MHz) to channel B14 (picture carrier 219,75 MHz)	channel E5 (p.c. 175,25 MHz) to channel E12 (p.c. 224,25 MHz)	channel ID (p.c. 175,25 MHz) to channel IJ (p.c. 215,25 MHz)
Intermediate frequencies			
picture	34,65 MHz	38,9 MHz	39,5 MHz
sound	38,15 MHz	33,4 MHz	33,5 MHz

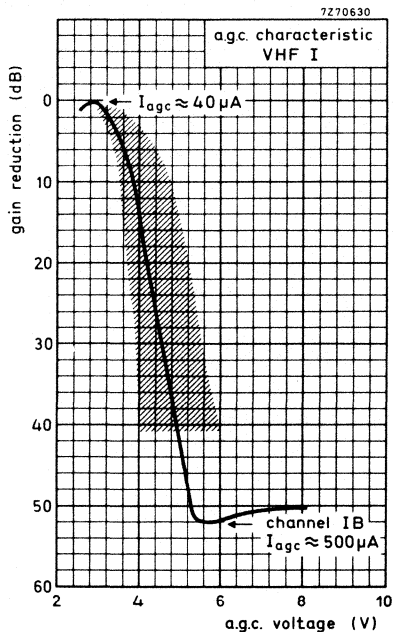

Fig. 5.

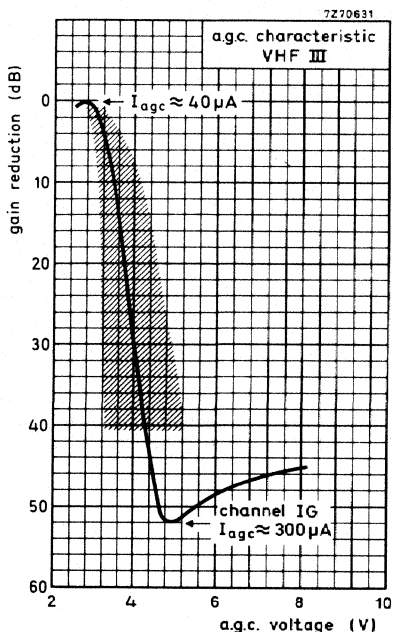

Fig. 6.

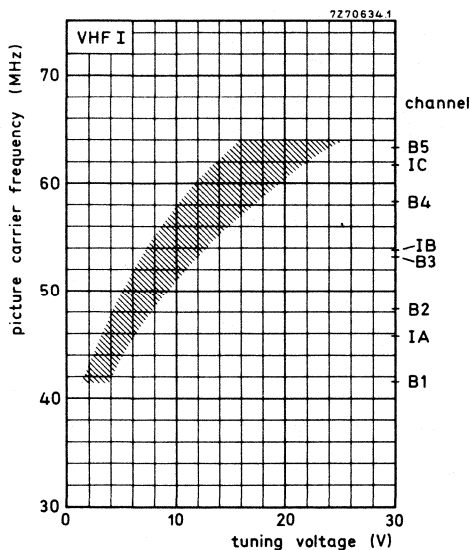

Fig. 7.

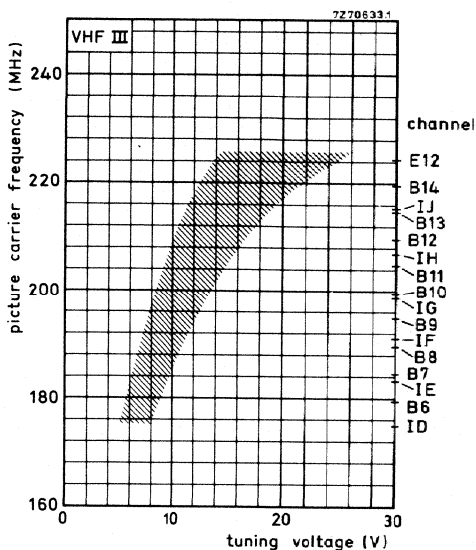

Fig. 8.



Input impedance	75 Ω	
asymmetrical	300 Ω (see ACCESSORIES)	
symmetrical		
V. S. W. R. (between picture carrier and sound carrier)	v. s. w. r. at nom. gain	max. v. s. w. r. during gain control
band I (except channel B1)	max. 3,5	max. 3,5
band III	max. 3,5	max. 3,5
A. G. C. range		
band I		min. 40 dB
band III		min. 40 dB
R. F. curves		
bandwidth, band I, except channel B1		typ. 10 to 12 MHz
band III		typ. 9 to 20 MHz
tilt, band I, except channel B1		max. 3 dB
band III, except channel E12		max. 3 dB
Power gain (see also ADDITIONAL INFORMATION)		
band I, except channel B1		min. 18 dB
channel B1		min. 16 dB
channel IA		typ. 20 dB
channel IC		typ. 22 dB
band III		min. 18 dB
channel ID		typ. 25 dB
channel IJ		typ. 24 dB
Noise figure		
band I, except channel B1		max. 10 dB
channel IB		typ. 7,5 dB
band III		max. 10 dB
channel IG		typ. 7,0 dB
I. F. rejection		
band I, channel B2		min. 30 dB
channel B5		min. 40 dB
band III		min. 60 dB
Image rejection		
band I		min. 60 dB
band III		min. 40 dB



Signal handling (see also Figs. 9 and 10)

Minimum input signal (e. m. f.) producing
cross modulation (1%) at nominal gain,
in channel

(wanted signal: picture carrier frequency,
interfering signal: sound carrier
frequency), v. h. f. I
v. h. f. III

typ. 8 to 14 mV }
typ. 6 to 10 mV } Note 1

in band

(wanted signal: picture carrier frequency
of channel X,
interfering signal: picture carrier of
channel X-2

v. h. f. I }
v. h. f. III } typ. 60 to 100 mV }
typ. 20 to 30 mV } Note 1

Minimum input signal (e. m. f.) producing
overloading, at nominal gain

v. h. f. I }
v. h. f. III } typ. 20 mV }
typ. 13 mV } Note 2

at maximum a. g. c.

v. h. f. I }
v. h. f. III } min. 200 mV }
min. 200 mV } Note 2

Minimum input signal (e. m. f.) at nominal
gain producing a shift of the oscillator
frequency of 20 kHz

typ. 20 to 50 mV (Note 3)

Detuning of the i. f. output circuit as a
result of bandswitching and tuning

max. 200 kHz

Shift of oscillator frequency

at a change of the supply voltage of 10%

band I }
band III } max. 300 kHz }
max. 300 kHz }

during warm-up time (measured between 3 s
and 60 s after switching on)

band I }
band III } max. 50 kHz }
max. 50 kHz }

Note 1 - This e. m. f. is referred to an impedance of 75 Ω .

1% cross modulation means that 1% of the modulation depth of the interfering
signal is transferred to the wanted signal.

Note 2 - This e. m. f. is referred to an impedance of 75 Ω .

Criterion of overloading: 30% compression of the synchronization pulses of a
standard television signal or a noticeable deterioration of the picture quality.

Note 3 - This e. m. f. is referred to an impedance of 75 Ω .



Drift of oscillator frequency

at a change of the ambient temperature
from 25 to 40 °C

band I

max. 400 kHz

band III

max. 400 kHz

**Oscillator radiation (oscillator voltages at
the aerial terminal)**

The oscillator radiation will be within the limits of BS905: 1969 provided no connection has been made to the test point and the circuit connected to the i. f. output is carefully shielded.

For the oscillator fundamentals use is made of the relaxed limits, assuming that the design of the i. f. amplifier of the receiver is such that a detuning of the oscillator of -2, 0 MHz or +0, 6 MHz from the nominal frequency will result in unacceptable picture and/or sound degradation.

Immunity from radiated interference

If the tuner, including the aerial connection (see Fig. 4) is installed in a professional manner, the immunity from radiated interference will be within the limits specified in BS905: 1969.

If a higher safety margin, or another cable connection is required, use can be made of an immunity shield (see ACCESSORIES).

Microphonics

If the tuner is installed in a professional manner, there will be no noticeable microphonics.

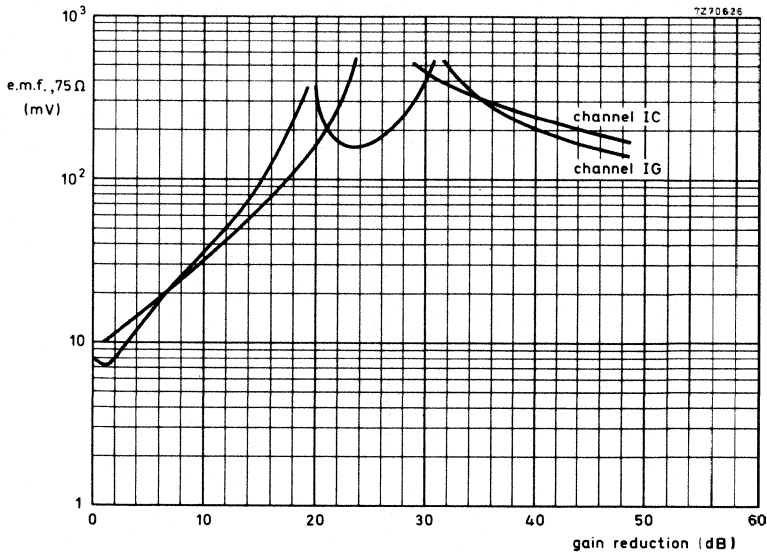

Fig. 9. Cross modulation, in channel.

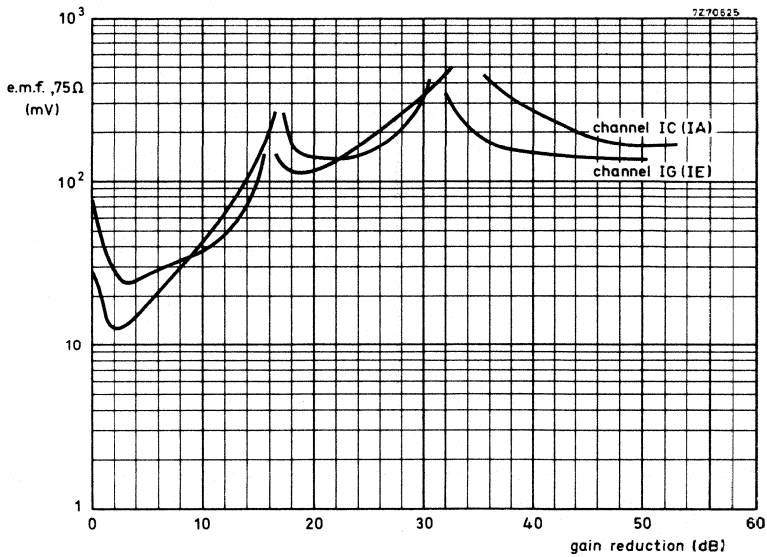

Fig. 10. Cross modulation, in band; the interfering channels are given between brackets.



ADDITIONAL INFORMATION

Measuring method of power gain

The i.f. output of the tuner should be terminated with the circuit given below, the test-point (terminal 9) not being connected.

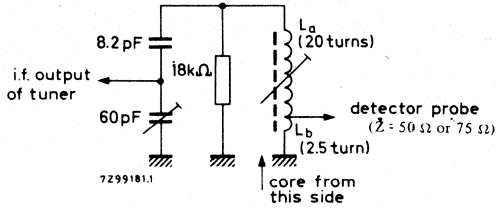

Fig. 11.

Feed an i.f. sweep signal to the v.h.f. I-mixer coupling coil.

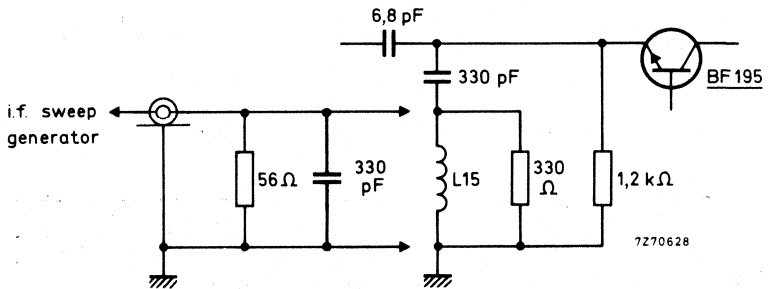

Fig. 12.

Adjust the trimmer (Fig. 11), tunable coil La/Lb, i.f. output coil of the tuner L18 (Fig. 1), and the coupling between La and Lb to get the resonant curve as given below.

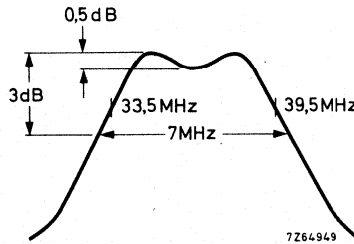

Fig. 13

Display the r. f. + i. f. curve of the tuner at 190 MHz (picture carrier frequency) and make, if necessary, small corrections in the alignment of the i. f. coils (L_a/L_b and L18) to get the markers 39,5 MHz and 33,5 MHz symmetrically on the slopes of the curve, and the peaks at equal amplitude.

Because the output impedance of the dummy circuit is 50 to 75 Ω , the power gain can be measured in the conventional manner by inserting tuner and dummy circuit between a 75 Ω source and a 75 Ω detector (or between a 50 Ω source and matching pad 50/75 Ω and a 50 Ω detector).

ACCESSORIES

Aerial input transformer ELC 1094, catalogue number 3122 107 10121, for converting the aerial input from 75 Ω asymmetric to 300 Ω symmetric.

Immunity shield for screening the aerial connection, consisting of:
shield, catalogue number 4313 132 01910
clamp, catalogue number 4313 132 01890

OTHER AVAILABLE VERSION

ELC1042 - catalogue number 2422 542 10421.

This tuner is identical with the ELC1042/05 except that the i. f. coil L18 of the ELC1042 has four additional turns.



U.H.F. TELEVISION TUNER

with diode tuning

QUICK REFERENCE DATA

Systems	C. C. I. R systems G and I	
Channels	21 to 69	
Intermediate frequencies	<u>system G</u>	<u>system I</u>
picture	38,9 MHz	39,5 MHz
sound	33,4 MHz	33,5 MHz

APPLICATION

Designed to cover the u. h. f. channels 21 to 69 of C. C. I. R. systems G and I.



DESCRIPTION

The ELC1043/05 is an u.h.f. tuner with electronic tuning covering the u.h.f. bands IV and V (frequency range 470 to 860 MHz).

Mechanically the tuner is built on a low-loss printed-wiring board, carrying all components, in a metal housing made of a rectangular frame and front and rear cover (see Fig. 2). The aerial connection is on the frame side, all other connections (supply voltages, a.g.c. voltage and tuning voltage) are made via feedthrough capacitors in the under side. The mounting method is shown in Figs. 3 and 4.

The tuner is of the three transistor type, comprising two r.f. stages and an oscillator/mixer. The input circuit is untuned, so that optimum noise figures may be realised, whilst the additional r.f. stage compensates for the increased insertion loss associated with diode tuned circuits.

Coupling between the first and second r.f. stages is by a half-wave tuned line, between the second r.f. stage and the mixer is by bandpass half-wave tuned lines. The secondary of the bandpass is coupled to the emitter of the oscillator/mixer stage via a coupling loop, which also provides the inductive feedback of the oscillator.

Half-wave lines, terminated at one end by a fixed capacitor and tuned at the other end by a variable capacitance diode, are used throughout.

The tuner requires transistor supply voltages of +12 V, a.g.c. voltages, variable from +2,5 V (normal operating point) to about +7,5 V (maximum a.g.c.) and a tuning voltage, variable from +0,3 V to +25 V.

The aerial input of the tuner is asymmetrical. For use in symmetrical aerial systems, aerial transformers (baluns) are available (see ACCESSORIES).

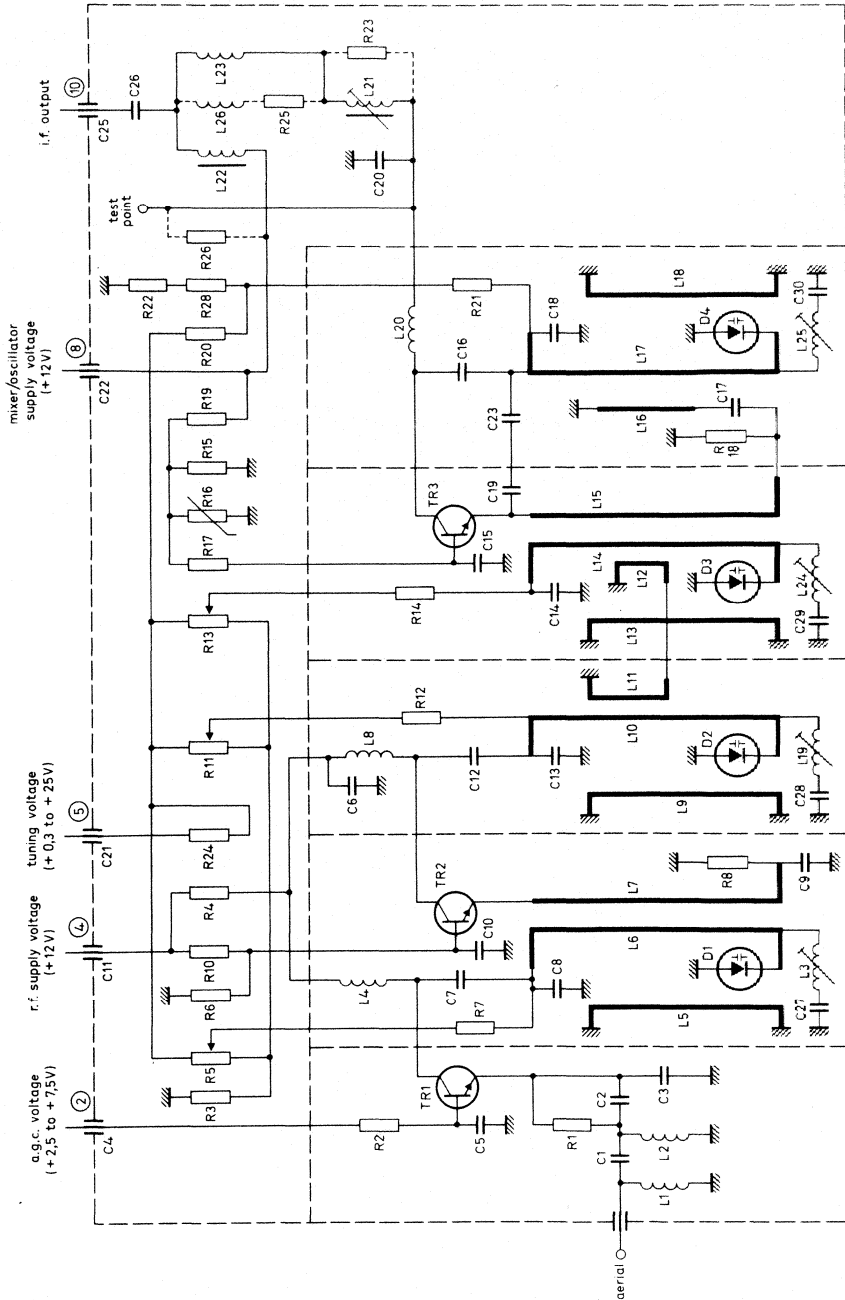
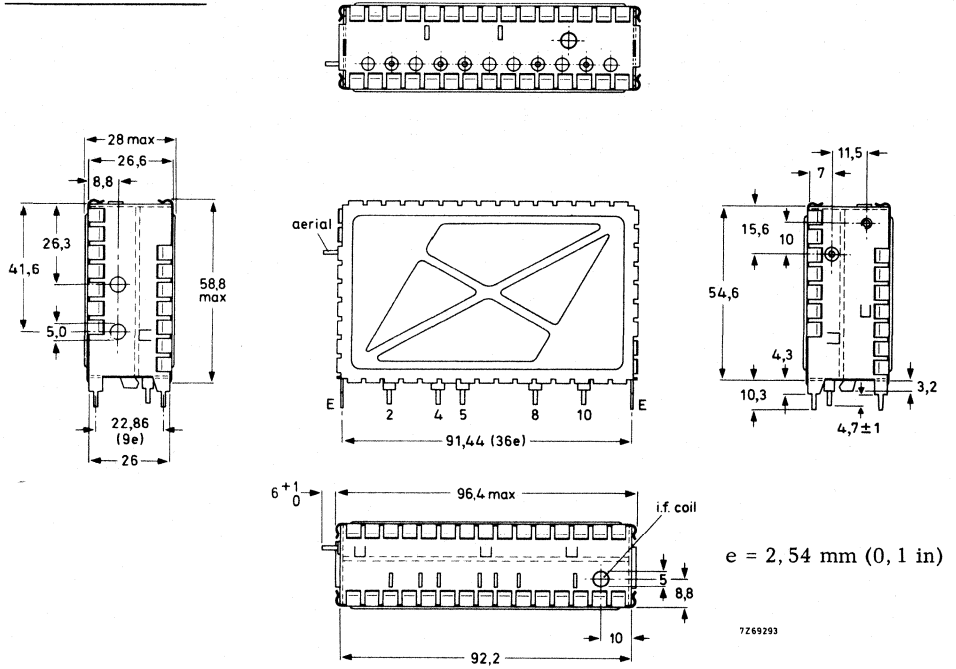

Fig. 1.



MECHANICAL DATA

Dimensions in mm



Terminal 2 = a. g. c. voltage, +2,5 to +7,5 V

4 = r. f. supply voltage, +12 V (approx. 8,8 to 13 mA)

5 = tuning voltage, +0,3 to +25 V

8 = mixer/oscillator supply voltage, +12 V (approx. 3,6 mA)

10 = i. f. output

E = earth

Mounting

The tuner may be mounted by soldering it on to a printed-wiring board, using the piercing diagram shown in Fig. 3. (The tuner may also be mounted by means of a snap-in mount or a bracket. Information will be supplied upon request).

The tuner may be mounted anywhere in the receiver and there are no restrictions on orientation.

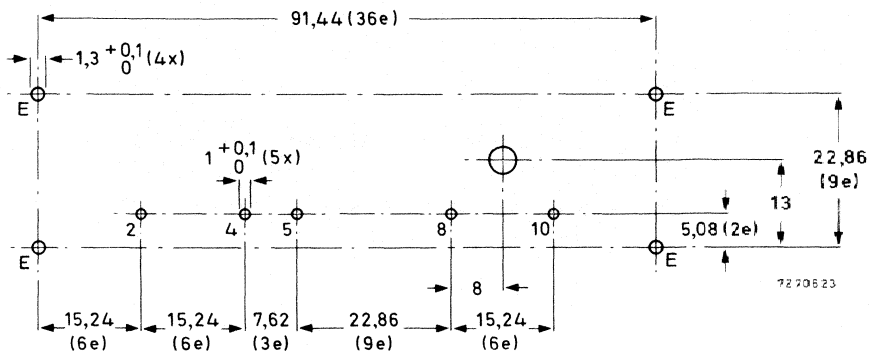

Fig. 3. Piercing diagram viewed from solder side of board; $e = 2,54 \text{ mm (0,1 in)}$

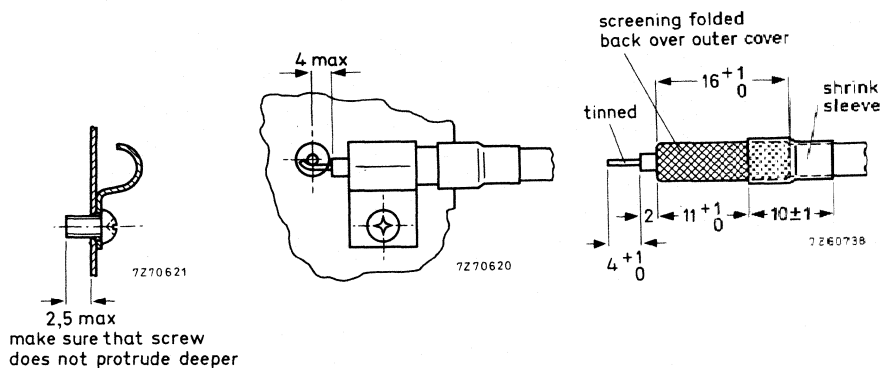

Fig. 4 Recommended fixing method of the aerial cable. Use a self-tapping screw.

ELECTRICAL DATA

Unless otherwise specified all electrical values apply at an ambient temperature of 25 ± 5 °C and a supply voltage of $12 \pm 0,3$ V

Semiconductors, r. f. amplifiers	2 x BF362	
mixer/oscillator	BF363	
tuning diodes	4 x BB205B	
Ambient temperature range		
operating	+5 to +55 °C	
storage	-25 to +85 °C	
Supply voltage	+12 V \pm 10%	
Current drawn from +12 V supply		
r. f. amplifiers	8,8 mA (at nominal gain) to 12 - 17 mA (at 30 dB gain reduction)	
mixer/oscillator	3,6 mA	
A.G.C. voltage (Fig. 5, typical curves)		
at nominal gain	+2,5 V	
at 30 dB gain reduction	approx. 6,0 V (max. 7,5 V)	
A.G.C. current at 30 dB gain reduction	max. 1,2 mA	
Tuning voltage range	+0,3 to +25 V	
Slope of tuning characteristic	min. 5 MHz/V	
Current drawn from 25 V tuning voltage supply	max. 20 μ A	
Frequency range	channel 21 (picture carrier 471,25 MHz) to channel 69 (picture carrier 855,25 MHz). Margin at the extreme channels min. 3 MHz	
Intermediate frequencies	<u>system G</u>	<u>system I</u>
picture	38,9 MHz	39,5 MHz
sound	33,4 MHz	33,5 MHz
Input impedance		
asymmetrical	75 Ω	
symmetrical	300 Ω (see ACCESSORIES)	
V.S.W.R. (between picture carrier and sound carrier)	v. s. w. r. at nom. gain, without a. g. c.	max. v. s. w. r. during gain con- trol up to 30 dB
	max. 4,0	max. 6,0

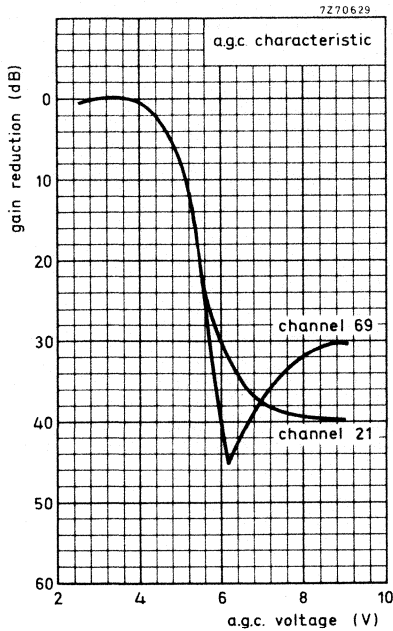

Fig. 5

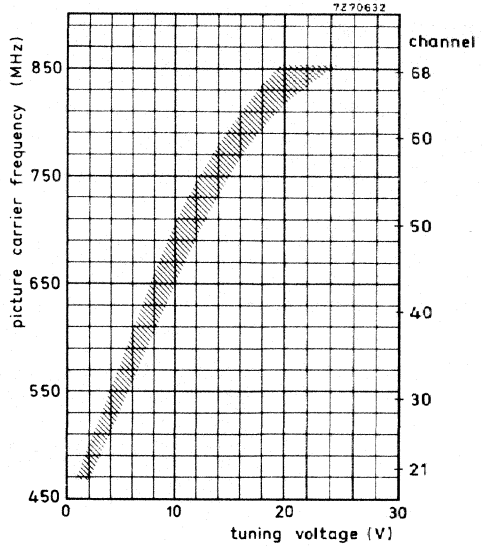

Fig. 6

A.G.C. range	min. 30 dB
R.F. curves	
bandwidth	typ. 10 to 20 MHz
tilt	max. 4,0 dB (0 to 2 dB typical)
Power gain (see also ADDITIONAL INFORMATION)	min. 17 dB
channel 21	typ. 22 dB
channel 50	typ. 22 dB
channel 68	typ. 22 dB
Noise figure	max. 10 dB
channel 21	typ. 6,0 dB
channel 50	typ. 6,5 dB
channel 68	typ. 7,0 dB
I.F. rejection	min. 60 dB
Image rejection, channels 21 to 61	min. 53 dB
n + 4 rejection	min. 53 dB
(Obtained between the picture carrier of the wanted channel n and the sound carrier of an unwanted signal spaced 4 channels above the wanted channel.)	



Signal handling

Minimum input signal (e. m. f.) producing cross modulation (1%) at nominal gain, in channel
(wanted signal: picture carrier frequency, interfering signal: sound carrier frequency).

typ. 8 mV (Note 1)

in band
(wanted signal: picture carrier frequency of channel X, interfering signal: picture carrier of channel X-5)

typ. 25 mV (Note 1)

Minimum input signal (e. m. f.) producing overloading, at nominal gain at maximum a. g. c.

typ. 15 to 20 mV (Note 2)
min. 250 mV (Note 2)

Minimum input signal (e. m. f.) at nominal gain producing a shift of the oscillator frequency of 20 kHz

typ. 5 to 15 mV (Note 3)

Detuning of the i. f. output circuit as a result of tuning

max. 150 kHz

Shift of oscillator frequency at a change of the supply voltage of 10%

max. 500 kHz

during warm-up time (measured between 3 s and 60 s after switching on)

max. 200 kHz

at a gain reduction of 30 dB

max. 100 kHz

Drift of oscillator frequency

at a change of the ambient temperature from 25 to 50 °C

max. 1000 kHz

Note 1- This e. m. f. is referred to an impedance of 75 Ω.

1% cross modulation means that 1% of the modulation depth of the interfering signal is transferred to the wanted signal.

Note 2- This e. m. f. is referred to an impedance of 75 Ω.

Criterion of overloading: 30% compression of the synchronization pulses of a standard television signal or a noticeable deterioration of the picture quality.

Note 3- This e. m. f. is referred to an impedance of 75 Ω.

Oscillator radiation (oscillator voltages at the aerial terminal)

The oscillator radiation will be within the limits of BS905:1969 provided the circuit connected to the i. f. output is carefully shielded.

For the oscillator fundamentals use is made of the relaxed limits, assuming that the design of the i. f. amplifier of the receiver is such that a detuning of the oscillator of - 2,0 MHz or +0,6 MHz from the nominal frequency will result in unacceptable picture and/or sound degradation.

Immunity from radiated interference

If the tuner, including the aerial connection (see Fig. 4) is installed in a professional manner, the immunity from radiated interference will be within the limits specified in BS905:1969.

If a higher safety margin, or another cable connection is required, use can be made of an immunity shield (see ACCESSORIES).

Microphonics

If the tuner is installed in a professional manner, there will be no noticeable microphonics.



ADDITIONAL INFORMATION

Measuring method of power gain

The i. f. output of the tuner should be terminated with the circuit given below.

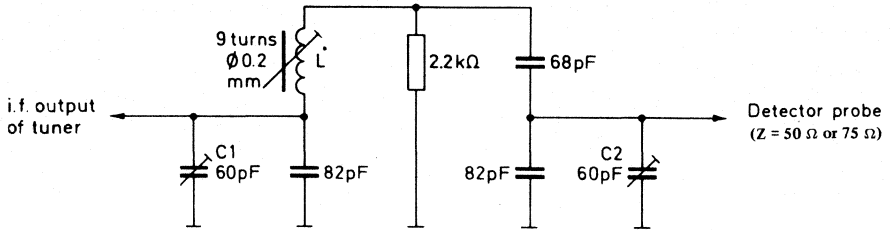

Fig. 7.

Feed an i. f. sweep signal to the emitter of the BF363 (mixer/oscillator) and make the oscillator inoperative (e.g. ferrite core in resonant chamber).

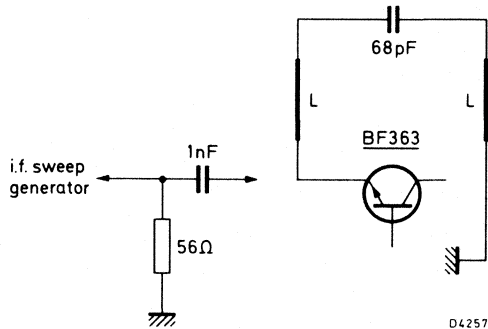

Fig. 8.

Adjust the trimmers C1 and C2, coil L (Fig. 7) and the i. f. output coil of the tuner (L21) to get the resonant curve with maximum gain as shown below.

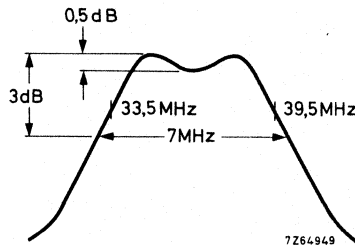

Fig. 9

7264948

Display the r.f. + i.f. curve of the tuner at 470 MHz and make, if necessary, small corrections in the alignment of C1, C2, L and L21 to get the markers 33,5 MHz and 39,5 MHz symmetrically on the slopes of the curve, and the peaks at equal amplitude.

Because the output impedance of the dummy circuit is 50 to 75 Ω , the power gain can be measured in the conventional manner by inserting tuner and dummy circuit between a 75 Ω source and a 75 Ω detector (or between a 50 Ω source and matching pad 50/75 Ω and a 50 Ω detector).

ACCESSORIES

Aerial input transformer ELC 1095, catalogue number 2422 542 10951, for converting the aerial input from 75 Ω asymmetric to 300 Ω symmetric.

Immunity shield for screening the aerial connection, consisting of:
shield, catalogue number 4313 132 01910
clamp, catalogue number 4313 132 01890

OTHER AVAILABLE VERSION

ELC1043/06 - See the relevant data sheet.



U.H.F. TELEVISION TUNER with diode tuning

These data should be read in conjunction with data on ELC 1043/05.

This type is identical to ELC 1043/05 except for the following:

- The i.f. output circuit consists of an i.f. coil with increased turns damped by a 680Ω resistor. This changes the tuning range and Q of the i.f. output coil, making it suitable for coupling to a block filter input i.f. amplifier.
- The power gain is reduced to a nominal of 12 dB and a minimum of 9 dB by the damping resistor mentioned above.
- The same dummy circuit is used for measuring power gain but, as a result of damping the i.f. coil, a single tuned response will appear at the output, instead of the double tuned response, as in the case of ELC 1043/05 (see below).

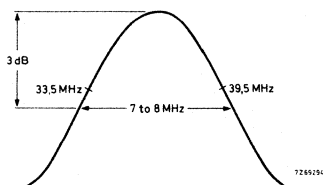

Fig. 1

V.H.F./U.H.F. TELEVISION TUNER

with diode tuning

QUICK REFERENCE DATA

Systems	C. C. I. R. systems B and G
Channels	E2 to C (band I) E5 to E12 (band III) E21 to E69 (bands IV and V)
Intermediate frequencies	
picture	38,9 MHz
sound	33,4 MHz

APPLICATION

Designed to cover the v. h. f. and u. h. f. channels of C. C. I. R. systems B and G, including the italian channels.



DESCRIPTION

The ELC 2000 is a combined v.h.f. /u.h.f. tuner with electronic tuning and band switching, covering the v.h.f. band I including the Italian channel C (frequency range 47 to 88 MHz), the v.h.f. band III (frequency range 174 to 230 MHz), and the u.h.f. band (frequency range 470 to 860 MHz).

Mechanically, the tuner is built on a low-loss printed-wiring board, carrying all components, in a metal housing made of a rectangular frame and front and rear cover (see Fig. 2). The two aerial connections (v.h.f. and u.h.f.) are on the two frame sides, all other connections (supply voltages, a.g.c. voltage, tuning and switching voltages) are made via feedthrough capacitors in the under side. The mounting method is shown in Figs. 3 and 4.

Electrically, the tuner consists of a v.h.f. and u.h.f. part. The v.h.f. aerial signal is fed via an i.f. trap, combined with a high pass filter, to a tuned input circuit, which is connected to the emitter of the input transistor BF 200. The collector load of this transistor is formed by a double tuned circuit, transferring the signal to the base of the mixer transistor BF 182. The oscillator is equipped with a transistor BF 194. The four r.f. circuits are tuned by four capacitance diodes BB 106. Switching between v.h.f. I and III is achieved by four switching diodes BA 243/244.

The collector circuit of the mixer transistor is a single tuned i.f. resonant circuit, at the low end of which the i.f. signal is capacitively coupled out of the tuner.

An i.f. injection point is provided at the collector of the mixer, for aligning this circuit together with the i.f. amplifier of the television receiver.

The u.h.f. part of the tuner consists of a tuned input circuit, connected to the emitter of the amplifier transistor BF 180. The interstage network between this transistor and the self-oscillating mixer stage is formed by a double tuned circuit. A transistor BF 181 acts as a self-oscillating mixer. The four tuned u.h.f. circuits are tuned by four capacitance diodes BB 105B.

The output of the self-oscillating mixer is fed to a double tuned i.f. circuit which is connected to the emitter of the v.h.f. mixer transistor BF 182, now operating as an i.f. amplifier in grounded base configuration. Band switching between v.h.f. and u.h.f. is achieved by another diode BA 243.

The tuner requires transistor supply voltages of +12 V, a switching voltage of +12 V, a.g.c. voltages, variable from +2,4 V (normal operating point) to about +7,5 V (maximum a.g.c.) and a tuning voltage, variable from +0,5 V to +28 V.

The aerial inputs of the tuner are asymmetrical. For use in symmetrical aerial systems, aerial transformers (baluns) are available (see ACCESSORIES).

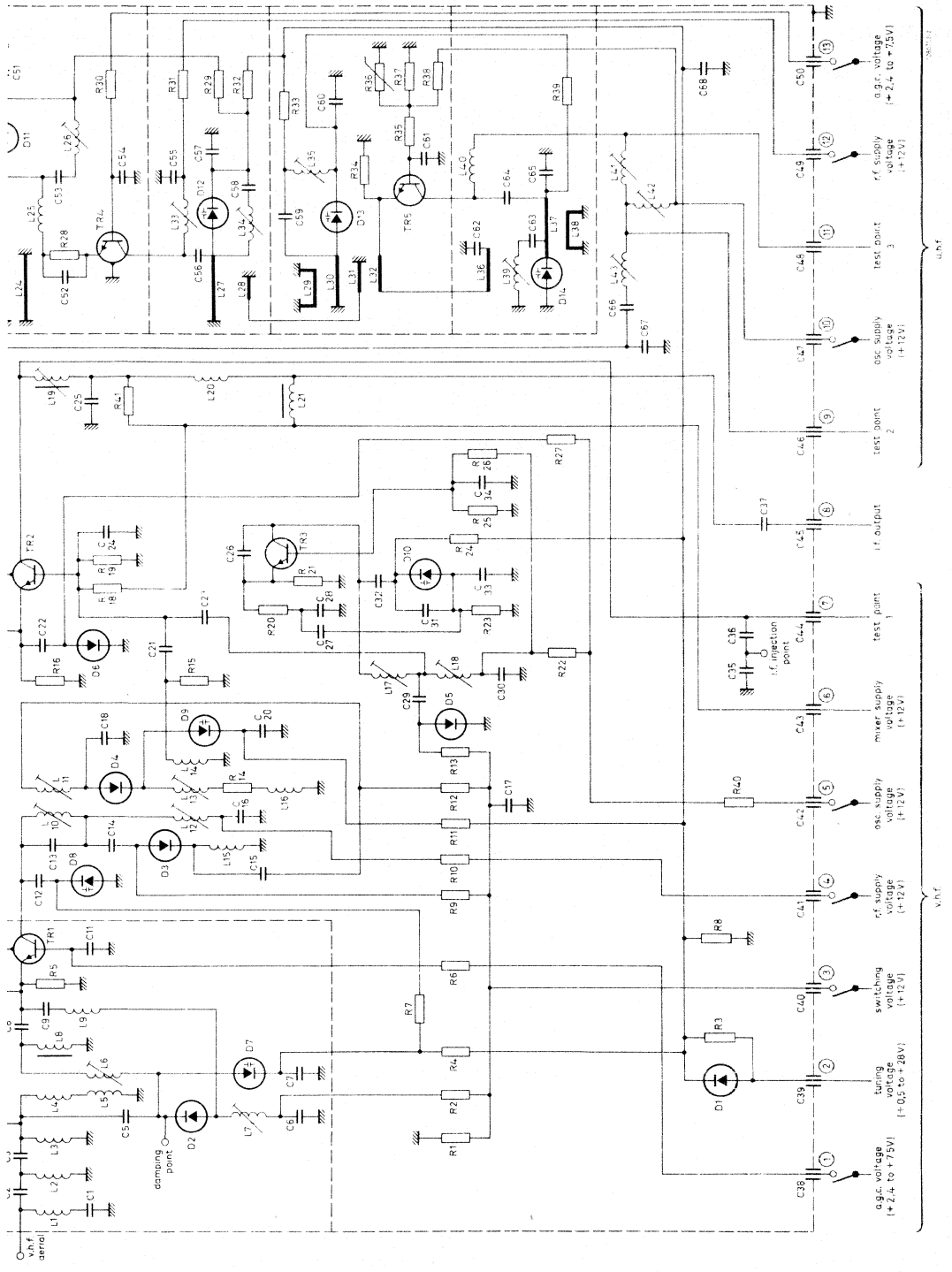

MECHANICAL DATA

Dimensions in mm

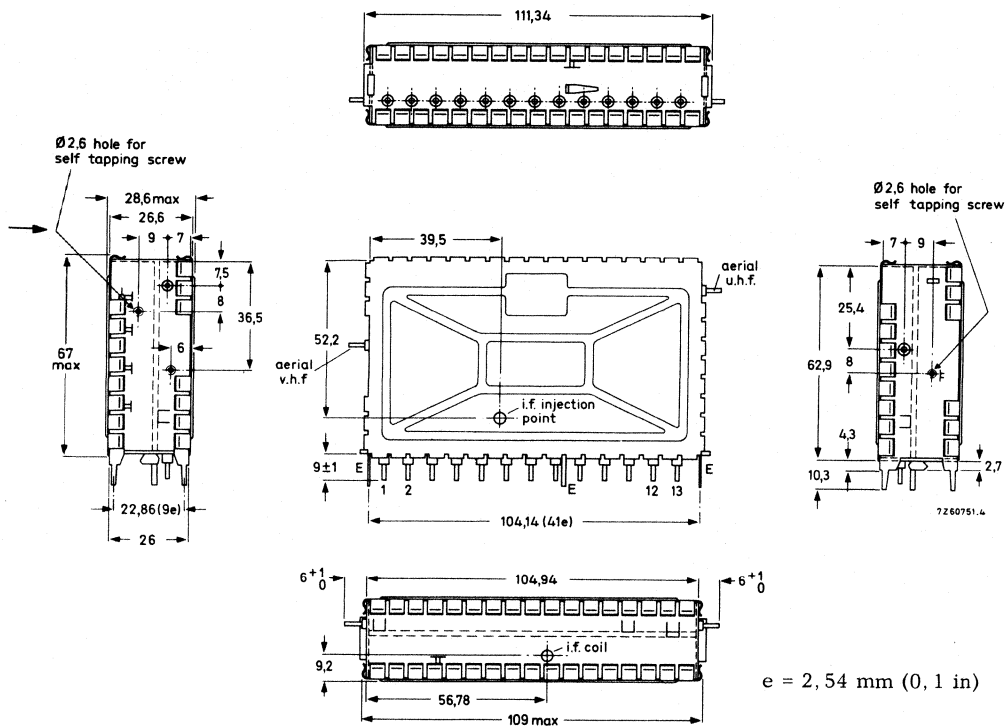

e = 2,54 mm (0,1 in)

Fig. 2

- Terminal 1 = a. g. c. voltage, v. h. f. , + 2,4 to + 7,5 V
- 2 = tuning voltage, + 0,5 to + 28 V
- 3 = switching voltage, + 12 V (approx. 20 mA)
- 4 = r. f. supply voltage, v. h. f. . + 12 V (approx. 3 to 10 mA)
- 5 = oscillator supply voltage, v. h. f. , + 12 V (approx. 6 mA)
- 6 = mixer supply voltage, v. h. f. . + 12 V (approx. 5 mA)
- 7 = test point 1, v. h. f.
- 8 = i. f. output
- 9 = test point 2 (alignment short)
- 10 = oscillator supply voltage, u. h. f. , + 12 V (approx. 4 mA)
- 11 = test point 3, u. h. f.
- 12 = r. f. supply voltage, u. h. f. , + 12 V (approx. 2,5 to 9,5 mA)
- 13 = a. g. c. voltage, u. h. f. , + 2,4 to + 7,5 V
- E = earth

Mounting

The tuner may be mounted by soldering it on to a printed-wiring board, using the piercing diagram shown in Fig. 3. (The tuner may also be mounted by means of a snap-in mount or a bracket. Information will be supplied upon request).

The tuner may be mounted anywhere in the receiver and there are no restrictions on orientation.

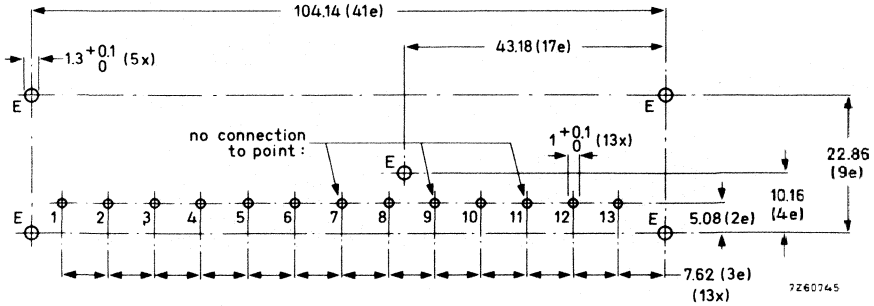

Fig. 3. Piercing diagram viewed from solder side of board; e = 2,54 mm (0,1 in).
No connection must be made to the points 7, 9 and 11, as otherwise the oscillator radiation would increase.

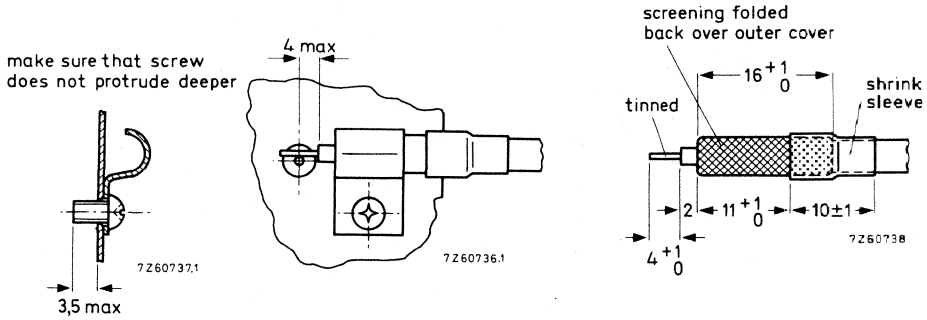

Fig. 4 Recommended fixing method of the aerial cables. Use a self-tapping screw.

ELECTRICAL DATA

Unless otherwise specified all electrical values apply at an ambient temperature of $25 \pm 5 \text{ }^\circ\text{C}$ and a supply voltage of $12 \pm 0,3 \text{ V}$.

Semiconductors

bands I and III, r. f. amplifier	BF200
mixer	BF 182
oscillator	BF 194
tuning diodes	4 x BB106
switching diodes	5 x BA243/244
bands IV and V, r. f. amplifier	BF 180
mixer/oscillator	BF 181
tuning diodes	4 x BB105B
drift compensating diode	BAW62

Ambient temperature range

operating	+5 to +55 $^\circ\text{C}$
storage	-25 to +85 $^\circ\text{C}$

Supply voltage

Current drawn from + 12 V supply + 12 V \pm 10%

band I	14 to 21 mA	} depending on a. g. c. voltage
band III	34 to 41 mA	
bands IV and V	31,5 to 38 mA	

A. G. C. voltage (Figs 5, 6 and 7)

band I, at nominal gain	2,4 V
at 40 dB gain reduction	5,5 V (typical)
band III, at nominal gain	2,4 V
at 40 dB gain reduction	4,5 V (typical)
bands IV and V, at nominal gain	2,4 V
at 30 dB gain reduction	5,0 V (typical)

A. G. C. current

band I	} at 40 dB gain reduction	max. 0,8 mA
band III		max. 0,6 mA
bands IV and V, at 30 dB gain reduction		max. 0,7 mA

Tuning voltage range (Figs. 8, 9 and 10)

Current drawn from 28 V tuning voltage supply + 0,5 to +28 V
max. 36 μA

Switching voltage

band I	open circuit
band III	+ 12 V
bands IV and V	+ 12 V

Note: In the band I position, the tuner produces a negative voltage (1 to 5 V) at terminal 3; this terminal must not be loaded with an external resistance below 10 M Ω .

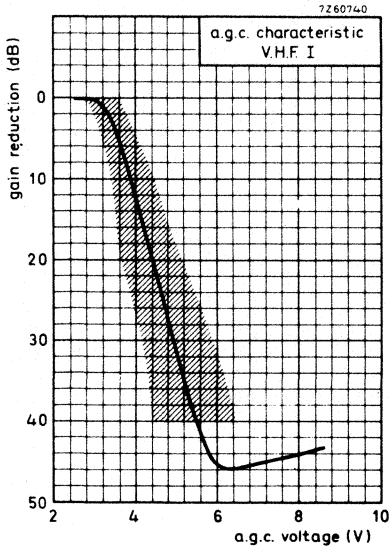

Fig. 5.

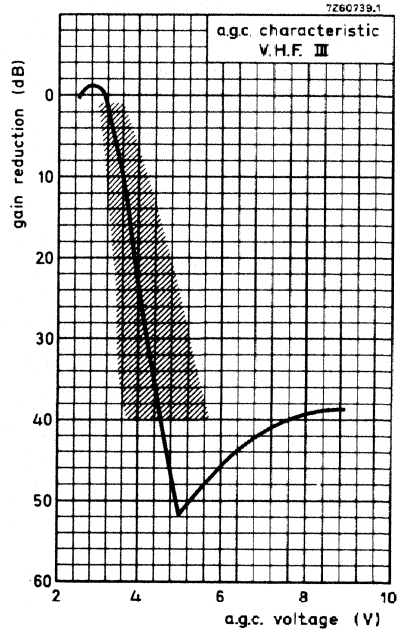

Fig. 6.

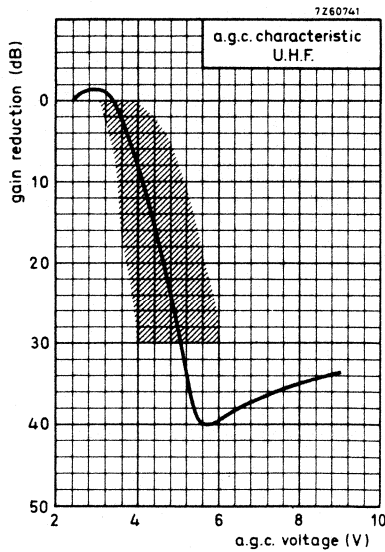

Fig. 7.



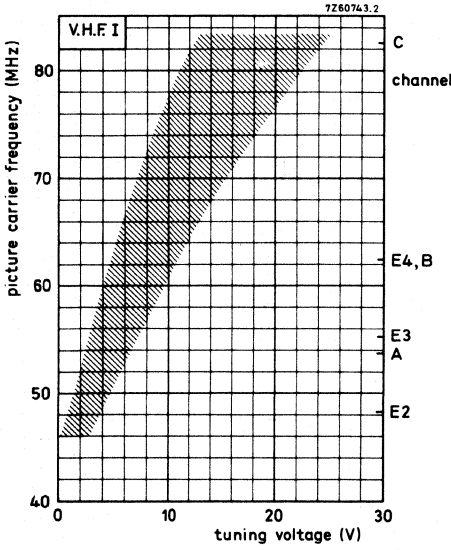

Fig. 8.

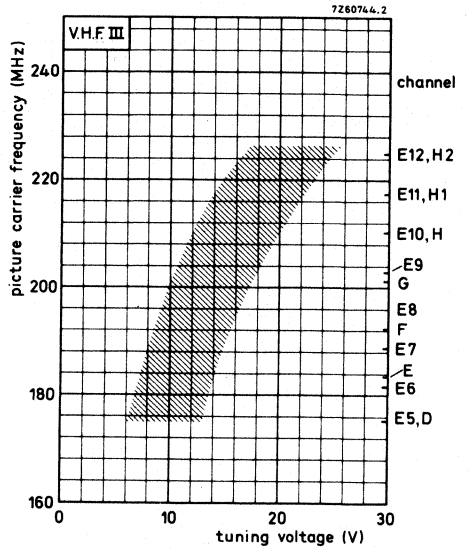

Fig. 9.

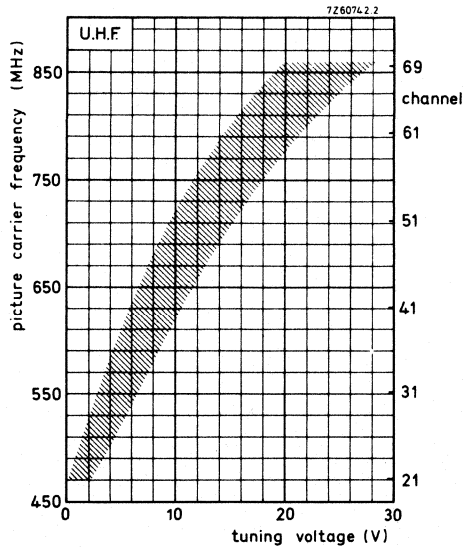

Fig. 10.

Frequency ranges

band I

channel E2 (picture carrier 48,25 MHz)
to channel C (picture carrier 82,25 MHz).
Margin at the extreme channels : min.
1,2 MHz.

band III

channel E5 (picture carrier 175,25 MHz)
to channel E12 (picture carrier 224,25 MHz).
Margin at the extreme channels : min.
2 MHz.

bands IV and V

channel E21 (picture carrier 471,25 MHz)
to channel E69 (picture carrier 855,25 MHz).
Margin at the extreme channels : min.
3 MHz.

Intermediate frequencies

picture

38,9 MHz

sound

33,4 MHz

Input impedance

asymmetrical

75 Ω

symmetrical

300 Ω (see ACCESSORIES)V. S. W. R. (between picture carrier
and sound carrier)v. s. w. r. at nom.
gainmax. v. s. w. r.
during gain
control

min. 1) max. 2)

min. 1) max. 2)

band I (except channel C)

max. 3 max. 4

max. 4 max. 5

band III (except channel E12)

max. 3 max. 4

max. 4 max. 5

bands IV and V

max. 4

max. 5

A. G. C. range

band I

min. 40 dB

band III

min. 40 dB

bands IV and V

min. 30 dB

1) Best value of V. S. W. R. between picture carrier and sound carrier.

2) Worst value of V. S. W. R. between picture carrier and sound carrier.

R. F. curves	
bandwidth, band I	typ. 10 to 15 MHz
band III	typ. 10 to 15 MHz
bands IV and V	typ. 15 to 25 MHz
tilt, band I	max. 3 dB
band III	max. 3 dB
bands IV and V, channels E21 to E60	max. 3 dB
channels E61 to E69	max. 4 dB
Power gain (see also MEASURING METHOD OF POWER GAIN)	
band I	min. 26 dB
channel E2	typ. 29 dB
channel C	typ. 32 dB
band III	min. 25 dB
channel E5	typ. 28 dB
channel E11	typ. 28 dB
bands IV and V	min. 25 dB
channel E21	typ. 32 dB
channel E31	typ. 29 dB
channel E69	typ. 33 dB
Noise figure	
band I	max. 8,5 dB
channel E4	typ. 6,5 dB
band III	max. 8 dB
channel E9	typ. 6,5 dB
bands IV and V	max. 12 dB
channel E21	typ. 8,0 dB
channel E51	typ. 9,5 dB
channel E69	typ. 10,5 dB
I. F. rejection	
band I, channel E2	min. 40 dB
channel C	min. 60 dB
band III	min. 60 dB
bands IV and V	min. 60 dB
Image rejection	
band I	min. 40 dB
band III	min. 60 dB
bands IV and V	min. 40 dB

Signal handling (see also Figs. 12 and 13)

Minimum input signal (e. m. f.) producing
cross modulation (1%) at nominal
gain, in channel

(wanted signal: picture carrier frequency,
interfering channel: sound carrier
frequency), v. h. f. I

v. h. f. III

u. h. f.

typ. 4 mV

typ. 4 mV

typ. 5 to 10 mV

} Note 1

in band

(wanted signal: picture carrier frequency
of channel X,

interfering signal: picture carrier of
channel X-2 (v. h. f.), X-5 (u. h. f.)

v. h. f. I

v. h. f. III

u. h. f.

typ. 15 to 60 mV

typ. 10 to 50 mV

typ. 15 to 50 mV

} Note 1

Minimum input signal (e. m. f.) producing
overloading, at nominal gain
at maximum a. g. c.

typ. 10 mV

typ. >200 mV

} Note 2

Minimum input signal (e. m. f.) at nominal
gain producing a shift of the oscillator
frequency of 10 kHz, band I

band III

bands IV and V

typ. >25 mV

typ. >25 mV

typ. 10 to 20 mV

} Note 3

Detuning of the i. f. output circuit as a result of
bandswitching and tuning with respect of channel E8

max. 400 kHz

Shift of oscillator frequency

at a change of the supply voltage of 10%

band I

band III

bands IV and V

max. 300 kHz

max. 300 kHz

max. 600 kHz

Note 1 - This e. m. f. is referred to an impedance of 75 Ω .

1% cross modulation means that 1% of the modulation depth of the interfering
signal is transferred to the wanted signal.

Note 2 - This e. m. f. is referred to an impedance of 75 Ω .

Criterion of overloading: 30% compression of the synchronization pulses of a
standard television signal or a noticeable deterioration of the picture quality.

Note 3 - This e. m. f. is referred to an impedance of 75 Ω .

during warm-up time (measured between 5 s and 15 min after switching on)

band I	max. 100 kHz
band III	max. 100 kHz
bands IV and V	max. 250 kHz
at a gain reduction of 30 dB	max. 100 kHz

Drift of oscillator frequency at a change of the ambient temperature from 25 to 40 °C

band I	max. 300 kHz
band III	max. 300 kHz
bands IV and V	max. 500 kHz

Oscillator radiation

The tuner is in conformity with the radiation requirements of C. I. S. P. R. Recommendation No. 24/3, provided the following conditions are fulfilled:

- A low-pass filter (Fig. 11) with a cut-off frequency of about 300 MHz has to be inserted between the v. h. f. aerial terminal of the tuner and the aerial terminal of the receiver. Television receivers with a common v. h. f. /u. h. f. connector in combination with a low-pass/high-pass splitter do not need this additional filter.

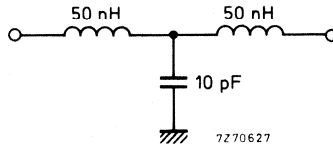

Fig. 11.

- No connections must be made to the terminals 7, 9, and 11.
- Earthing of the tuner and connections to the i. f. amplifier have to be made in such a way, that additional radiation is prevented.

Microphonics

If the tuner is installed in a professional manner, there will be no microphonics.

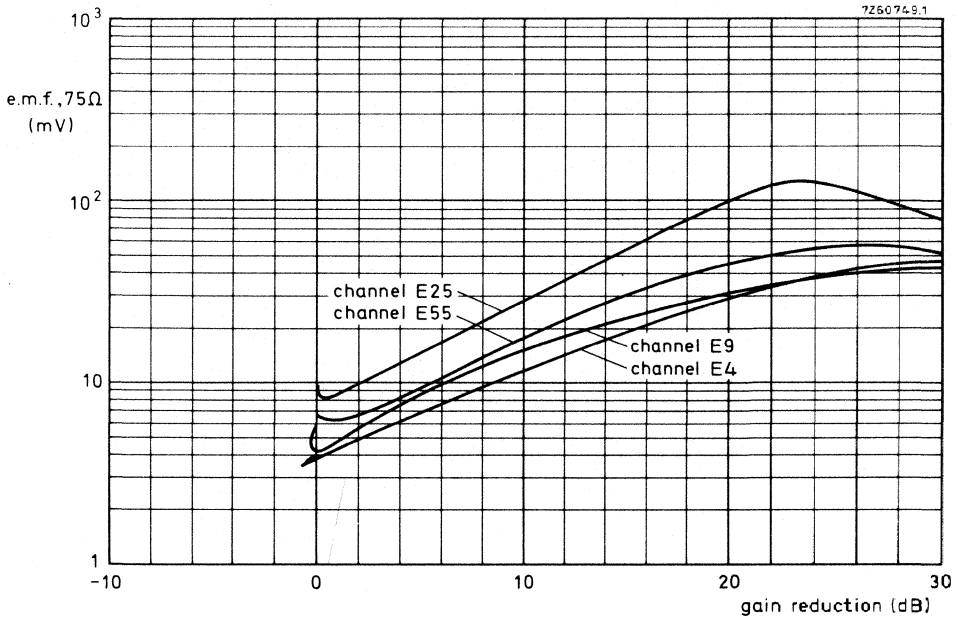

Fig. 12. Cross modulation, in channel.

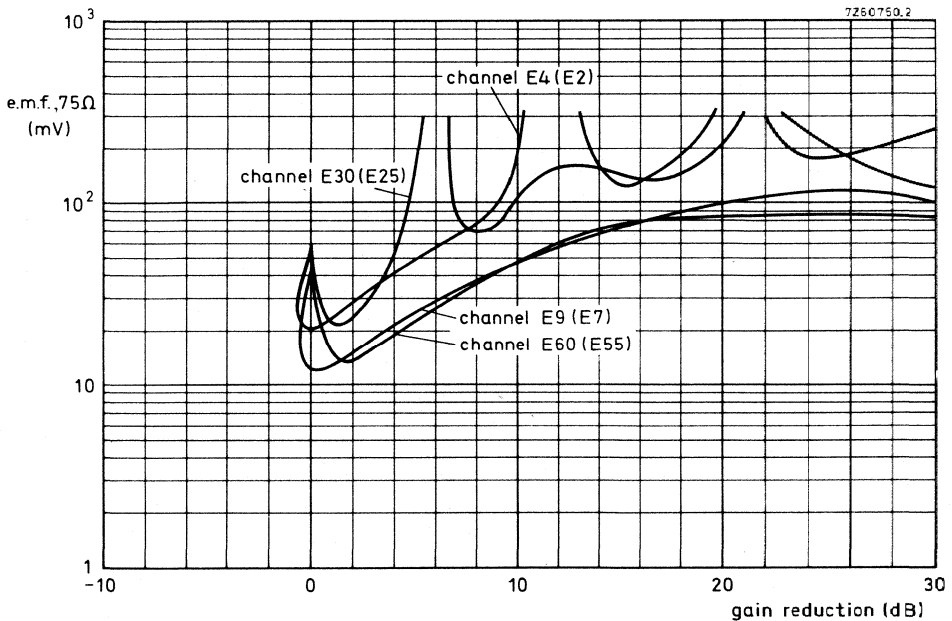

Fig. 13. Cross modulation, in band; the interfering channels are given between brackets.

APPLICATION INFORMATION

Connection of the tuner

For connection of the tuner the terminal location, Fig. 2, should be consulted. If the tuner is used in receivers the chassis of which is connected to the mains, isolating capacitors according to the safety rules have to be inserted in the aerial leads. Five ways of connecting, depending on the number of switches available, are given below.

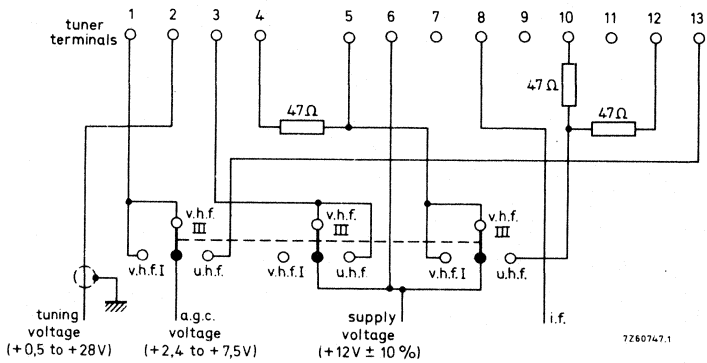

Fig. 14. Connection diagram with three switches.

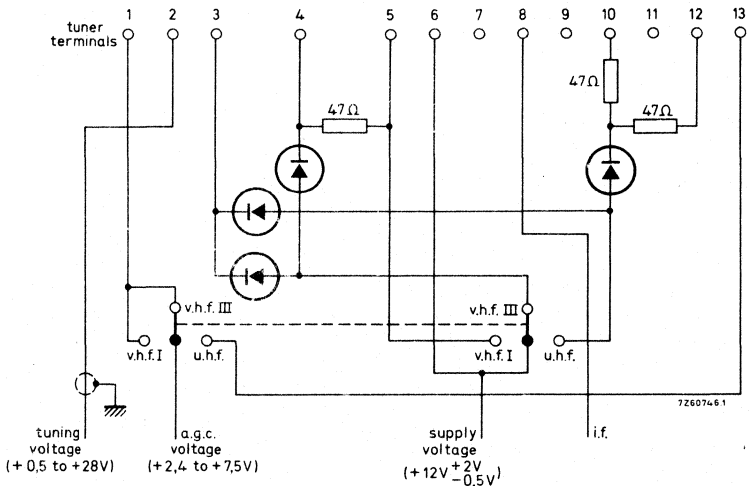

Fig. 15. Connection diagram with two switches.
All diodes: BAX13, BA217 or comparable silicon diodes.

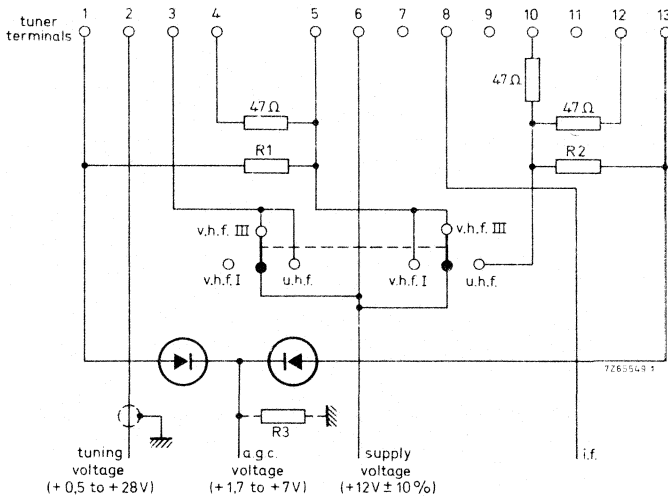

Fig. 16. Connection diagram with two switches.

All diodes: BAX13, BA217 or comparable silicon diodes.

The values of R₁, R₂ and R₃ are depending on a. g. c. circuit.

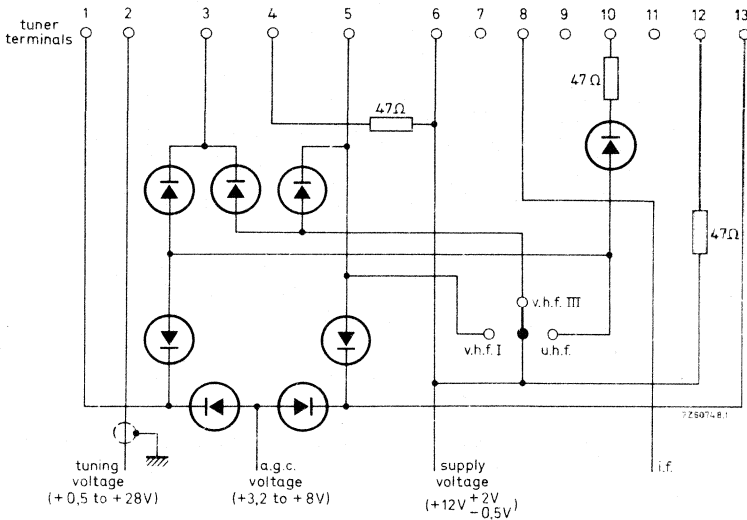

Fig. 17. Connection diagram with one switch.

All diodes: BAX13, BA217 or comparable silicon diodes.

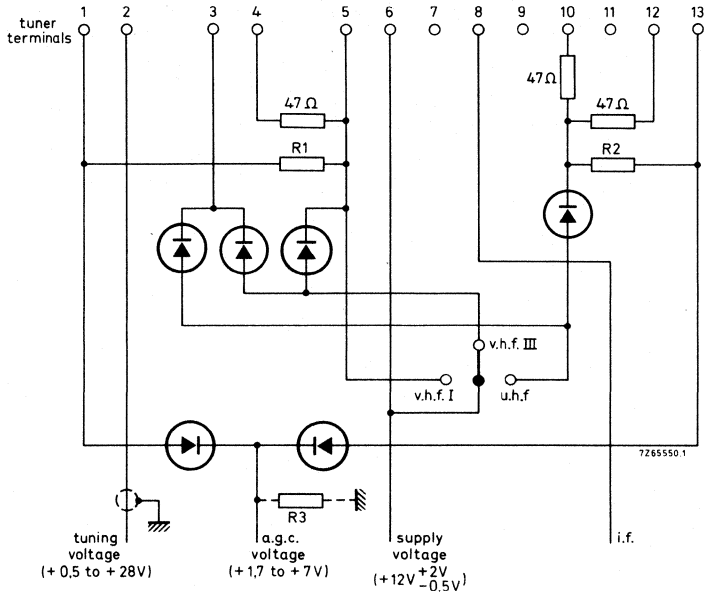

Fig. 18. Connection diagram with one switch.
All diodes: BAX13, BA217 or comparable silicon diodes. The values of R₁, R₂ and R₃ are depending on a.g.c. circuit.

Alignment of the i. f. circuit

The tuner is provided with an i. f. injection point at the collector of the mixer for aligning the i. f. circuit together with the i. f. amplifier of the television receiver (for the position of the i. f. injection point see Fig. 2).

The aligning should be done with the v. h. f. III band tuned. The tuning voltage should be 15 to 20 V.

If this injection method cannot be employed in the television receiver (e. g. because the injection point is not accessible or there is not enough i. f. signal available) use can be made of feeding the i. f. signal to test point 3 (terminal 11) via a capacitor of 0, 82 to 1pF. The tuner must be switched to the u. h. f. position; the tuning voltage should be approx. 10 V. This injection method requires approx. 14 dB less signal than the first method. No permanent connection must be made to test point 3, otherwise the tuner may exceed the oscillator radiation limits.

MEASURING METHOD OF POWER GAIN

The i. f. output of the tuner should be terminated with the circuit given below.
The terminals 7, 9 and 11 should be not connected.

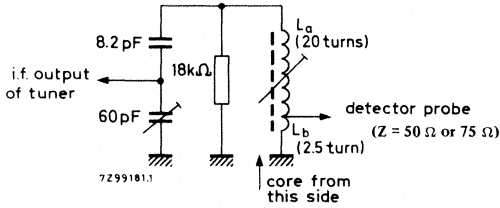

Fig. 19

Switch the tuner to the v. h. f. III band; the tuning voltage should be 15 to 20 V.
Feed an i. f. sweep signal (e. m. f. 500 to 1000 mV) to the i. f. injection point.
Adjust the trimmer (Fig. 19), tunable coil (L_a/L_b), i. f. output coil of the tuner L19
(Fig. 1) and the coupling between L_a and L_b to get the resonant curve as given below.

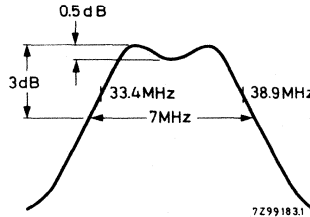

Fig. 20

Then display the r. f. + i. f. curve of the tuner at 190 MHz (picture carrier frequency) and make small corrections in the alignment of the i. f. coils (L_a/L_b and L19, if necessary, to get the markers 38,9 MHz and 33,4 MHz symmetrically on the slopes of the curve, and the peaks at equal amplitude.

Because the output impedance of the dummy circuit is 50 to 75 Ω , the power gain can be measured in the conventional manner by inserting tuner and dummy circuit between a 75 Ω source and a 75 Ω detector (or between a 50 Ω source and matching pad 50/75 Ω and a 50 Ω detector).

ACCESSORIES

Aerial input transformer ELC1094, v. h. f. , catalogue number: 2422 542 10941

Aerial input transformer ELC2092, u. h. f. , catalogue number: 2422 542 12921

V.H.F./U.H.F. TELEVISION TUNER**QUICK REFERENCE DATA**

Systems	C.C.I.R. systems B and G
Channels	New Zealand 1 to R4 (band I) M4 to E12 (band III) E21 to E69 (bands IV and V)
Intermediate frequencies	
picture	38,9 MHz
sound	33,4 MHz

APPLICATION

Designed to cover the v.h.f. and u.h.f. channels of C.C.I.R. systems B and G, with extended v.h.f. frequency ranges. This tuner is basically interchangeable with the ELC2000.



DESCRIPTION

The ELC2004 is a combined v.h.f./u.h.f. tuner with electronic tuning and band switching, covering the v.h.f. band I including the New Zealand channel 1, the Italian channel C and the OIRT channel R4 (frequency range 44 to 92 MHz), the v.h.f. band III including the Morocco channel M4 (frequency range 162 to 230 MHz), and the u.h.f. band (frequency range 470 to 861 MHz).

Mechanically, the tuner is built on a low-loss printed-wiring board, carrying all components, in a metal housing made of a rectangular frame and front and rear cover (see Fig. 2). The two aerial connections (v.h.f. and u.h.f.) are on the two frame sides, all other connections (supply voltages, a.g.c. voltage, tuning and switching voltages) are made via feed-through capacitors in the underside. The mounting method is shown in Figs 3 and 4.

Electrically, the tuner consists of v.h.f. and u.h.f. parts. The v.h.f. aerial signal is fed via an i.f. trap, combined with a high-pass filter and switchable bandpass filters, to the emitter of the input transistor BF200. The collector load of this transistor is formed by a double tuned circuit, transferring the signal to the base of the mixer transistor BF199. The oscillator is equipped with a transistor BF494. The three r.f. circuits are tuned by three capacitance diodes BB109G. Switching between v.h.f. I and III is achieved by five switching diodes BA243/244/182.

The collector circuit of the mixer transistor is a single tuned i.f. resonant circuit, at the low end of which the i.f. signal is capacitively coupled out of the tuner. A test point at the collector of the mixer can be used for i.f. injection to align the i.f. output circuit of the tuner together with the i.f. amplifier of the television receiver.

The u.h.f. part of the tuner consists of a high-pass input circuit, connected to the emitter of the amplifier transistor BF180. The interstage network between this transistor and the self-oscillating mixer stage is formed by a double tuned circuit. A transistor BF181 acts as a self-oscillating mixer. The three tuned u.h.f. circuits are tuned by three capacitance diodes BB105B. The output of the self-oscillating mixer is fed to a double tuned i.f. circuit which is connected to the base of the v.h.f. mixer transistor BF199, now operating as an i.f. amplifier.

The tuner requires transistor supply voltages of + 11 V, a switching voltage of + 11 V, a.g.c. voltages, variable from + 2,4 V (normal operating point) to about + 9 V (maximum a.g.c.) and a tuning voltage, variable from + 0,5 V to + 28 V.

The aerial inputs of the tuner are asymmetrical. For use in symmetrical aerial systems, aerial transformers (baluns) are available (see Accessories).

The ELC2004 tuner is basically interchangeable with the ELC2000. Small modifications in the receiver with respect to a.g.c. and supply voltages may be necessary.

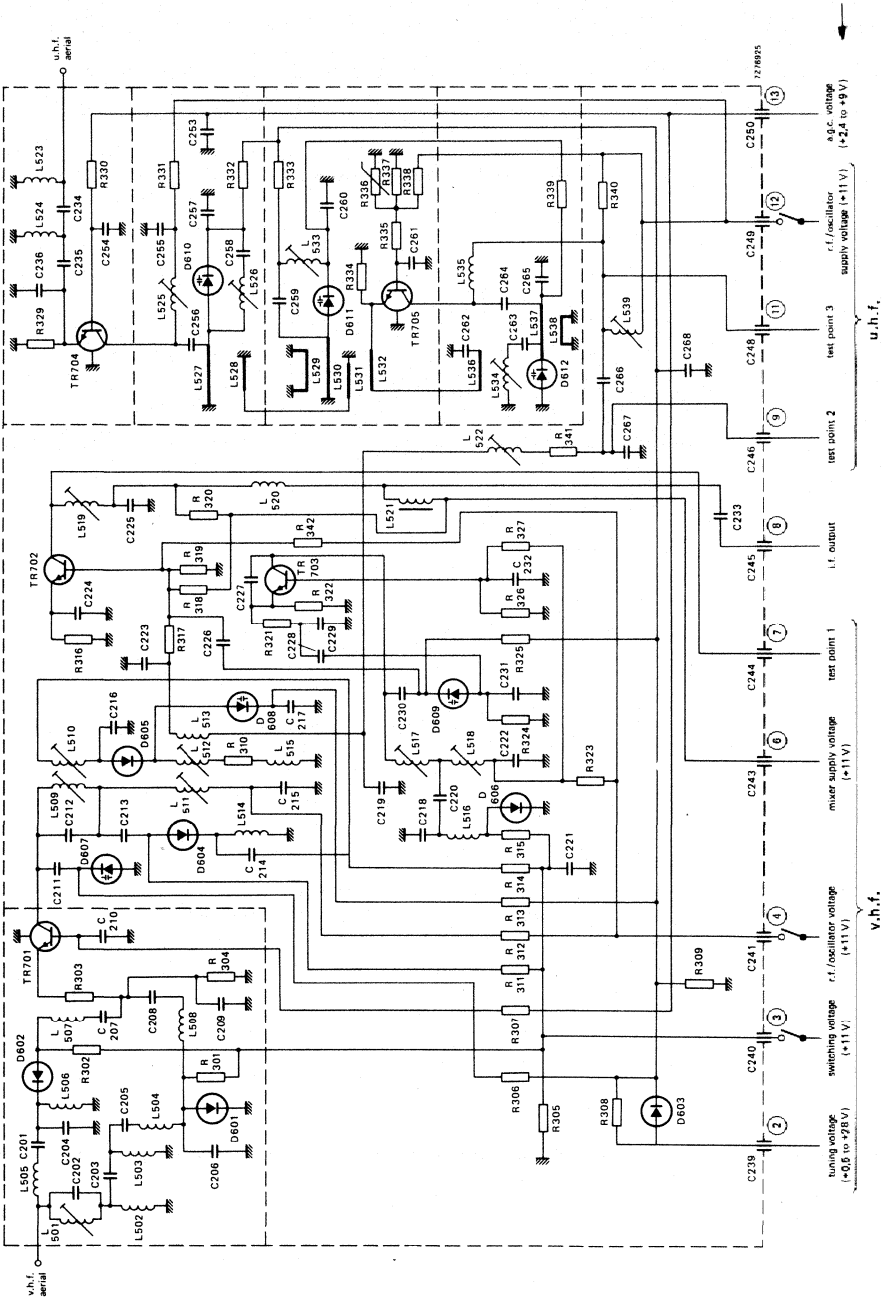
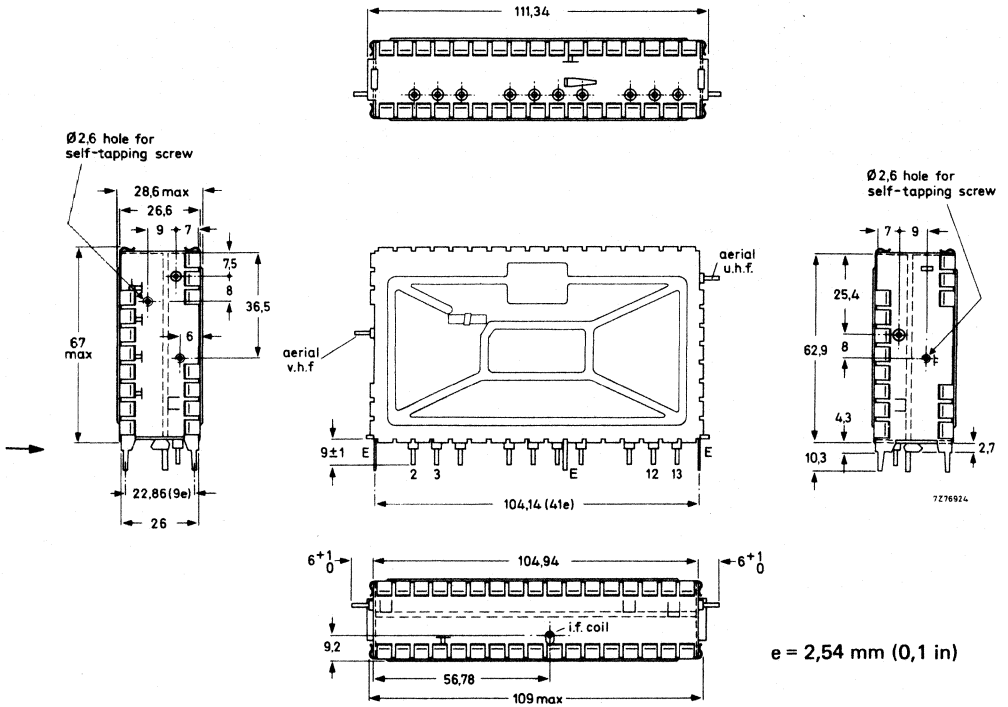

Fig. 1.



MECHANICAL DATA

Dimensions in mm



e = 2,54 mm (0,1 in)

Fig. 2.

- Terminal 2 = tuning voltage, + 0,5 to + 28 V
- 3 = switching voltage, + 11 V (approx. 20 mA)
- 4 = r.f./oscillator supply voltage, v.h.f., + 11 V (approx. 6 to 13 mA)
- 6 = mixer supply voltage, v.h.f., + 11 V (approx. 5 mA)
- 7 = test point 1, v.h.f.
- 8 = i.f. output
- 9 = test point 2 (alignment short)
- 11 = test point 3, u.h.f.
- 12 = r.f./oscillator supply voltage, u.h.f., + 11 V (approx. 6 to 13 mA)
- 13 = a.g.c. voltage, + 2,4 to + 9 V (3,5 mA)
- E = earth

Mounting

The tuner may be mounted by soldering it on to a printed-wiring board, using the piercing diagram shown in Fig. 3. (The tuner may also be mounted by means of a bracket. Information will be supplied upon request.) The tuner may be mounted anywhere in the receiver and there are no restrictions on orientation.

The solderability of the terminals and mounting tabs is according to IEC 68-2, test Ta ($230 \pm 10 \text{ }^\circ\text{C}$, $2 \pm 0,5 \text{ s}$). The resistance to soldering heat is according to IEC 68-2, test Tb ($260 \pm 5 \text{ }^\circ\text{C}$, $10 \pm 1 \text{ s}$).

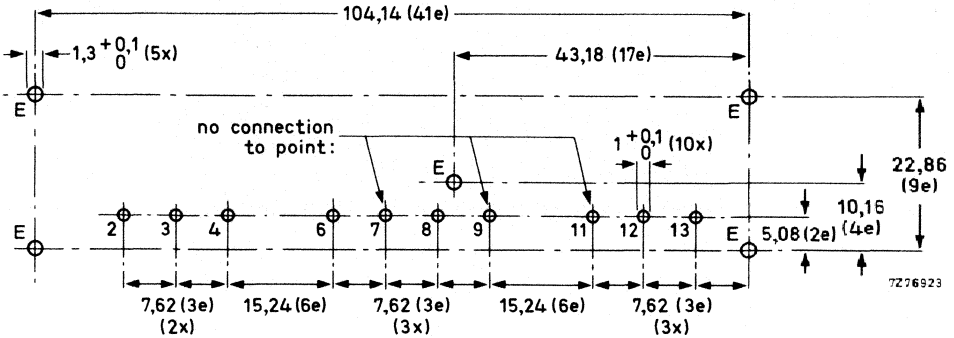

Fig. 3 Piercing diagram viewed from solder side of board; $e = 2,54 \text{ mm}$ ($0,1 \text{ in}$). No connection must be made to the points 7, 9 and 11, as otherwise the oscillator radiation would increase.

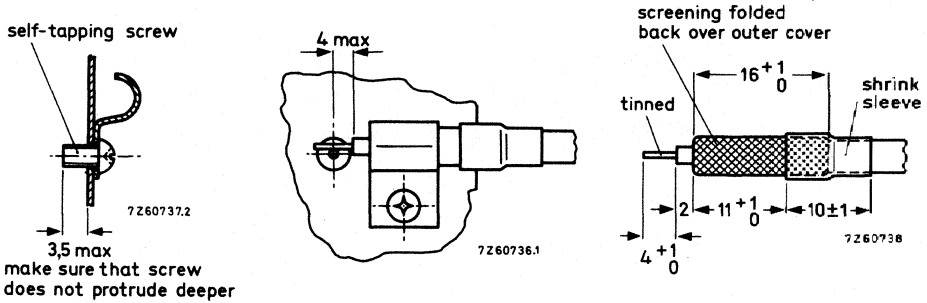

Fig. 4 Recommended fixing method of the aerial cables. Use a self-tapping screw.

ELECTRICAL DATA

Unless otherwise specified all electrical values apply at an ambient temperature of 25 ± 5 °C, a relative humidity of $60 \pm 15\%$, a supply voltage of $11 \pm 0,3$ V and an a.g.c. voltage of $2,4 \pm 0,2$ V.

Semiconductors, bands I and III

r.f. amplifier	BF200
mixer	BF199
oscillator	BF494
tuning diodes	3 x BB109G
→ switching diodes	5 x BA243/244/182

Semiconductors, bands IV and V

r.f. amplifier	BF180
mixer/oscillator	BF181
tuning diodes	3 x BB105B
drift compensating diode	BAW62

Ambient temperature range

operating	+ 5 to + 55 °C
storage	-25 to + 85 °C

Relative humidity

max. 90%

Supply voltage+ 11 V \pm 10%**Current drawn from + 11 V supply**

band I	11 to 18 mA	} depending on a.g.c. voltage
band III	31 to 38 mA	
bands IV and V	11 to 18 mA	

A.G.C. voltage (Figs 5, 6 and 7)

band I, at nominal gain	+ 2,4 V
band I, at 40 dB gain reduction	+ 6,0 V (typical)
band III, at nominal gain	+ 2,4 V
band III, at 40 dB gain reduction	+ 5,0 V (typical)
bands IV and V, at nominal gain	+ 2,4 V
bands IV and V, at 40 dB gain reduction	+ 5,5 V (typical)

Note: A.G.C. voltages between 0 and + 10 V may be applied without risk of damage.

A.G.C. current

max. 3,5 mA

Tuning voltage range (Figs 8, 9 and 10)

+ 0,5 to + 28 V

Current drawn from 28 V tuning voltage supplymax. 35 μ A

Note: The source impedance of the tuning voltage offered to terminal 2 must be maximum 30 k Ω at tuning voltages below 2 V.

Switching voltage

band I	open circuit
band III	+ 11 V \pm 10%
bands IV and V	open circuit

Note: In the band I position, the tuner produces a negative voltage (1 to 5 V) at terminal 3; this terminal must not be loaded with an external resistance below 10 M Ω .

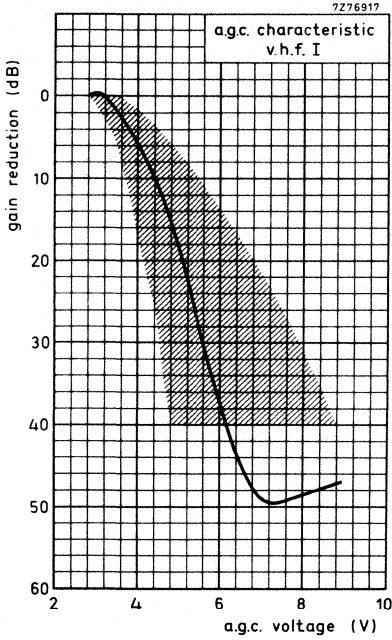

Fig. 5.

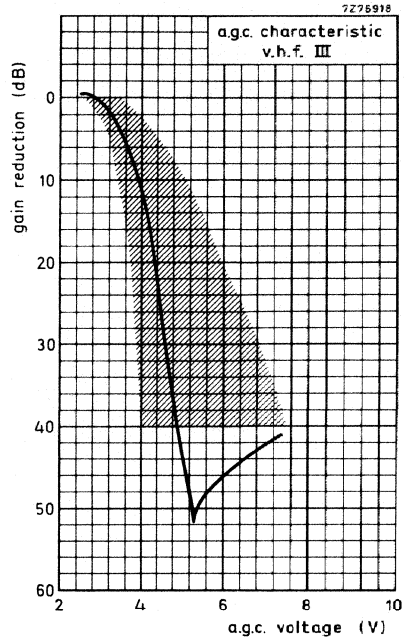

Fig. 6.

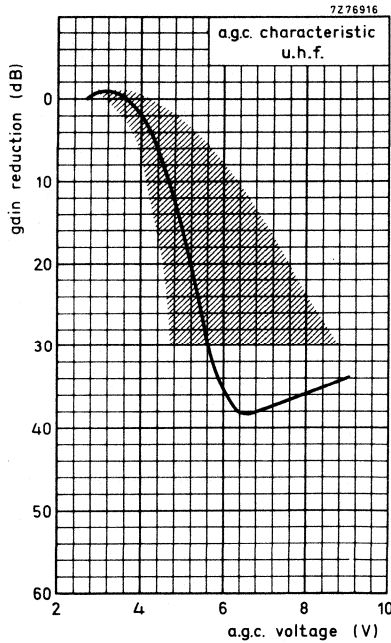

Fig. 7.



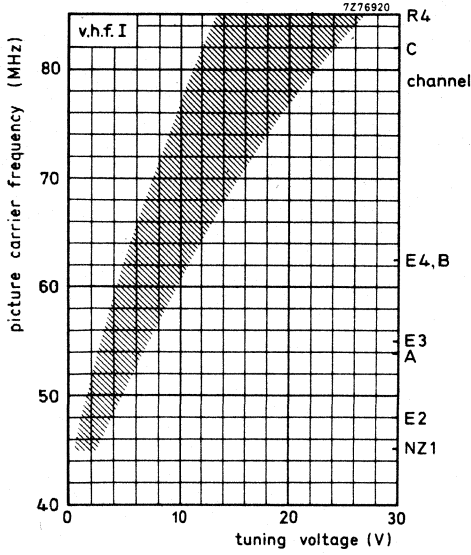

Fig. 8.

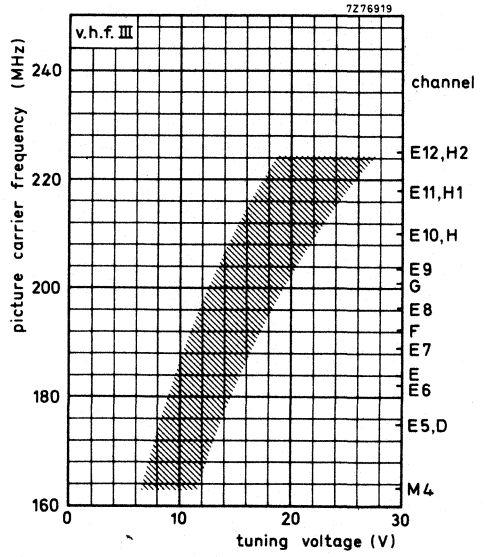

Fig. 9.

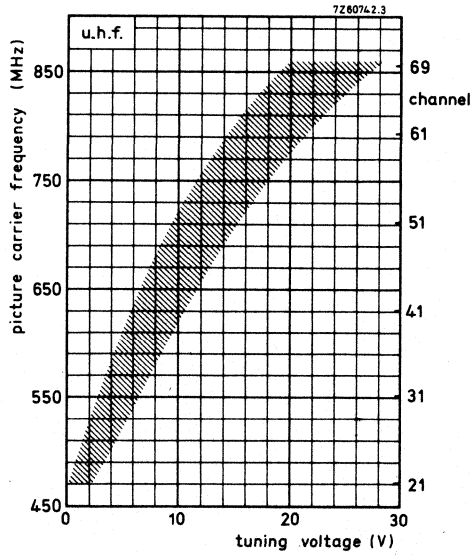

Fig. 10.

Frequency ranges		
band I	channel New Zealand 1 (picture carrier 45,25 MHz) to channel R4 (picture carrier 82,25 MHz). Margin at the extreme channels: min. 1,2 MHz.	
band III	channel M4 (picture carrier 163,25 MHz) to channel E12 (picture carrier 224,25 MHz). Margin at the extreme channels: min. 2 MHz.	
bands IV and V	channel E21 (picture carrier 471,25 MHz) to channel E69 (picture carrier 855,25 MHz). Margin at the extreme channels: min. 3 MHz.	
Intermediate frequencies		
picture	38,9 MHz	
sound	33,4 MHz	
Input impedance		
asymmetrical	75 Ω	
symmetrical	300 Ω (see Accessories)	
V.S.W.R. (between picture carrier and sound carrier)	v.s.w.r. at nom. gain	max. v.s.w.r. during gain control
band I, except channel NZ1	max. 4	max. 5
band I, channel NZ1	max. 5	max. 5
band III	max. 4	max. 5
bands IV and V	max. 5	max. 5
A.G.C. range		
band I	min. 40 dB	
band III	min. 40 dB	
bands IV and V	min. 30 dB	
R.F. curves, bandwidth		
band I	typ. 10 to 15 MHz	
band III	typ. 10 to 17 MHz	
bands IV and V	typ. 15 to 25 MHz	
R.F. curves, tilt		
band I	max. 3 dB	
band III	max. 3 dB	
bands IV and V, channels E21 to E60	max. 3 dB	
bands IV and V, channels E61 to E69	max. 4 dB	
Power gain (see also Measuring method of power gain)		
band I, except channel NZ1	min. 25 dB	
band I, channel NZ1	min. 24 dB	
band I, channel E2	typ. 28 dB	
band I, channel C	typ. 30 dB	
band III, except channel M4	min. 25 dB	
band III, channel M4	min. 24 dB	
band III, channel E5	typ. 27 dB	
band III, channel E11	typ. 29 dB	
bands IV and V	min. 25 dB	
bands IV and V, channel E21	typ. 30 dB	
bands IV and V, channel E31	typ. 28 dB	
bands IV and V, channel E69	typ. 32 dB	



Noise figure

band I, except channel NZ1	max. 8 dB
band I, channel NZ1	max. 9 dB
band I, channel E4	typ. 5,5 dB
band III, except channel M4	max. 8 dB
band III, channel M4	max. 10 dB
band III, channel E9	typ. 6 dB
bands IV and V	max. 11 dB
bands IV and V, channel E21	typ. 7 dB
bands IV and V, channel E51	typ. 8,5 dB
bands IV and V, channel E69	typ. 9 dB

I.F. rejection

band I, channel NZ1	min. 34 dB
band I, channel E2	min. 40 dB
band I, channel C	min. 60 dB
band III	min. 60 dB
bands IV and V	min. 60 dB

Image rejection

band I	min. 40 dB
band III	min. 60 dB
bands IV and V	min. 40 dB

Signal handling (see also Figs 12 and 13)

Minimum input signal (e.m.f.) producing cross-modulation (1%) at nominal gain in channel (wanted signal: picture carrier frequency; interfering signal: sound carrier frequency)

v.h.f. I	typ. 4 mV	} notes 1 and 2
v.h.f. III	typ. 4 mV	
u.h.f.	typ. 5 to 10 mV	

Minimum input signal (e.m.f.) producing cross-modulation (1%) at nominal gain in band (wanted signal: picture carrier frequency of channel X; interfering signal: picture carrier of v.h.f. channel X-2, u.h.f. channel X-5)

v.h.f. I	typ. 20 to 40 mV	} notes 1 and 2
v.h.f. III	typ. 10 to 20 mV	
u.h.f.	typ. 10 to 20 mV	

Minimum input signal (e.m.f.) producing overloading

at nominal gain	typ. 30 mV	} notes 1 and 3
at maximum a.g.c.	typ. > 200 mV	

Minimum input signal (e.m.f.) at nominal gain producing a shift of oscillator frequency of 10 kHz

band I	typ. > 25 mV	} note 1
band III	typ. > 25 mV	
band IV and V	typ. 6 to 10 mV	

Detuning of the i.f. output circuit as a result of band switching and tuning with respect to channel E8

max. 400 kHz

Shift of oscillator frequency at a change of supply voltage of 10%

band I	max. 300 kHz
band III	max. 300 kHz
band IV and V	max. 600 kHz

Shift of oscillator frequency at a gain reduction of 30 dB

max. 100 kHz

Notes see page 11.

Drift of oscillator frequency during warm-up time

(measured between 5 s and 15 min after switching on)

band I	max. 100 kHz
band III	max. 100 kHz
bands IV and V	max. 250 kHz

Drift of oscillator frequency at a change of ambient temperature from 25 to 40 °C

band I	max. 300 kHz
band III	max. 300 kHz
bands IV and V	max. 500 kHz

Oscillator radiation

The tuner is in conformity with the radiation requirements of C.I.S.P.R. publication No. 13, provided the following conditions are fulfilled.

- A low-pass filter (Fig. 11) with a cut-off frequency of about 300 MHz has to be inserted between the v.h.f. aerial terminal of the tuner and the aerial terminal of the receiver.
Television receivers with a common v.h.f./u.h.f. connector in combination with a low-pass/high-pass splitter do not need this additional filter.

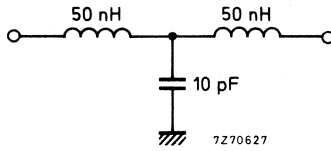

Fig. 11.

- No connections must be made to terminals 7, 9 and 11.
- Earthing of the tuner and connections to the i.f. amplifier has to be done in such a way, that additional radiation is prevented.

Microphonics

If the tuner is installed in a professional manner, there will be no microphonics.

Surge protection

Protection against voltages max. 8 kV

Note: Three discharges of a 470 pF capacitor into the aerial terminal.

Protection against flashes max. 30 kV, 400 mWs

Note: A flash-over circuit producing flashes with frequencies of 1 to 20 Hz for 30 s is connected to the aerial terminal.

Notes

1. Referred to an impedance of 75 Ω.
2. 1% cross-modulation means that 1% of the modulation depth of the interfering signal is transferred to the wanted signal.
3. Criterion of overloading: 30% compression of the synchronization pulses of a standard television signal or a noticeable deterioration of the picture quality.



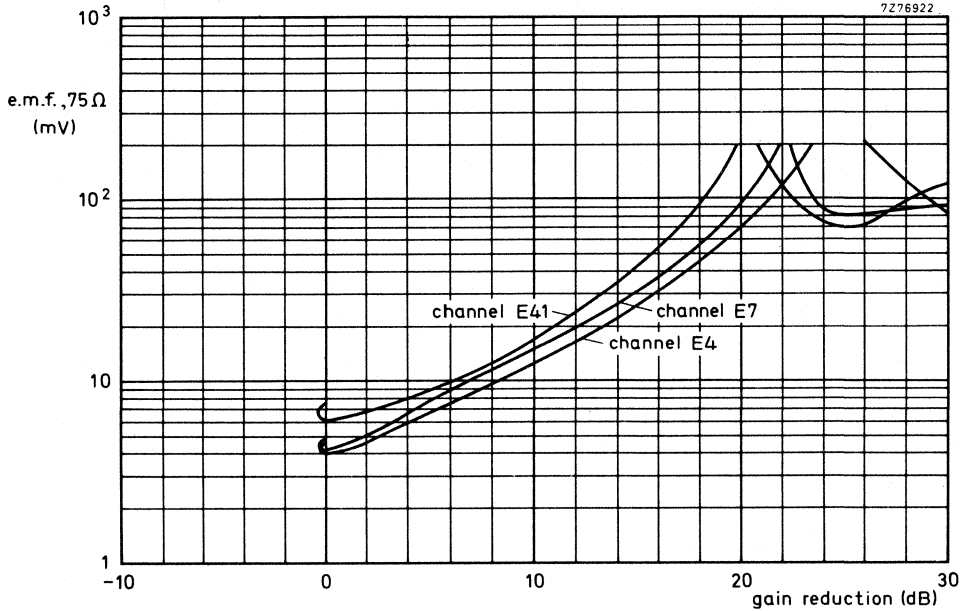

Fig. 12 Cross-modulation, in channel.

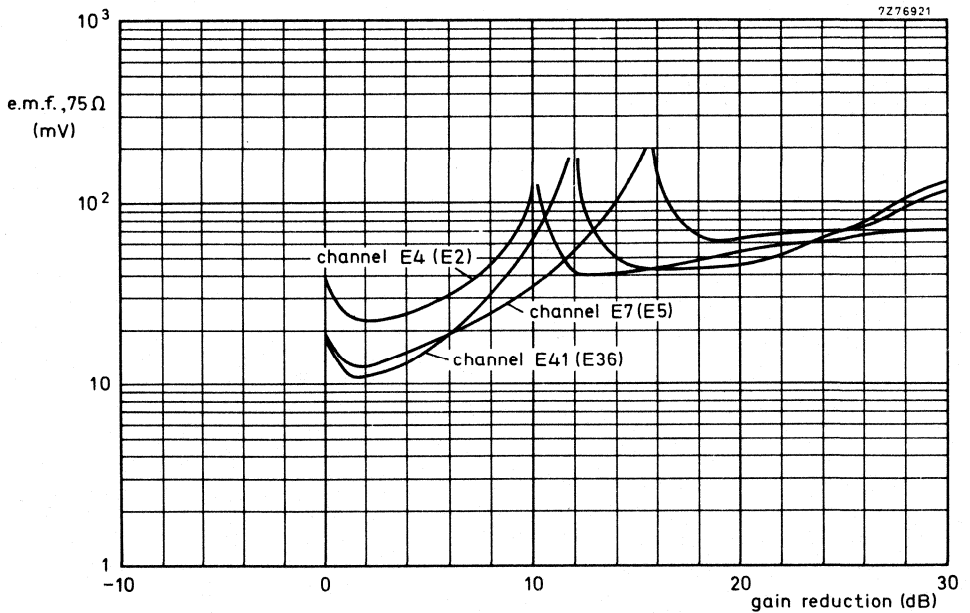

Fig. 13 Cross-modulation, in band; the interfering channels are given between brackets.

APPLICATION INFORMATION

Connection of the tuner

For connection of the tuner the terminal location, Fig. 2, should be consulted. If the tuner is used in receivers the chassis of which is connected to the mains, isolating capacitors according to the safety rules have to be inserted in the aerial leads. A convenient way of connecting is given below.

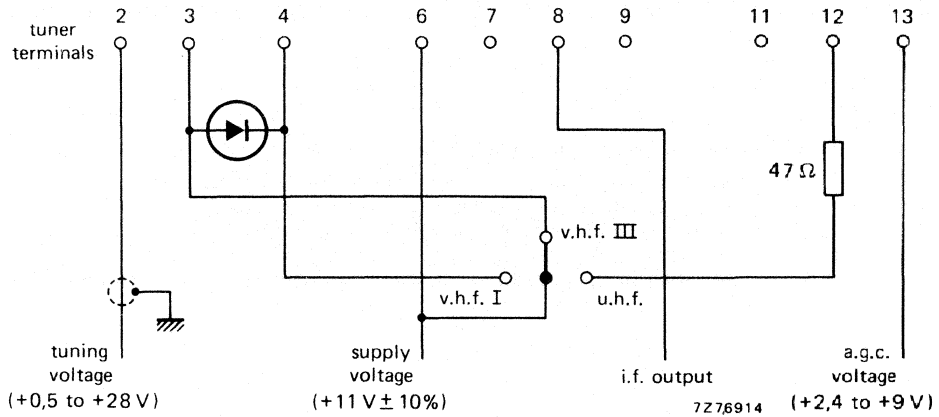

Fig. 14 Connection diagram; diode: BAX13, BA217 or comparable silicon diode.

Alignment of the i.f. circuit

The tuner is provided with a test point at the collector of the v.h.f. mixer, which can be used for i.f. injection to align the i.f. output circuit. The i.f. signal should be fed to test point 1 (terminal 7) via a capacitor of 0,5 to 1 pF (Fig. 15). This capacitor should have short leads to avoid oscillator radiation. After alignment it should be soldered to earth, to avoid detuning of the i.f. circuit (Fig. 16).

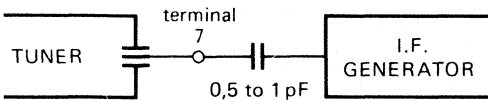

Fig. 15.

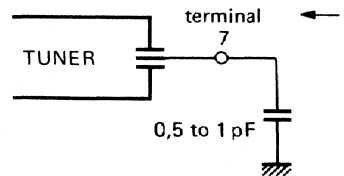

Fig. 16.

In receivers where the tuner is soldered into a printed-wiring board, the capacitor can be printed as shown in Figs 17 and 18.

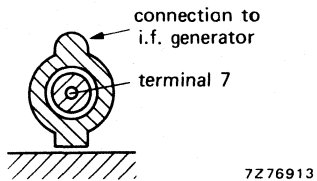

Fig. 17.

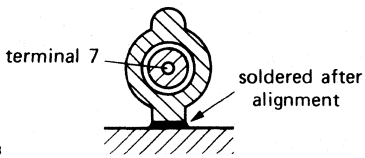

Fig. 18.

The aligning should be done with the v.h.f. III band tuned. The tuning voltage should be 15 to 20 V. If this injection method cannot be employed in the television receiver (e.g. there is not enough i.f. signal available) the i.f. signal can be fed to test point 3 (terminal 11) via a capacitor of 0,82 to 1 pF. The tuner must be switched to the u.h.f. position; the tuning voltage should be approx. 10 V. This injection method requires approx. 14 dB less signal than the first method. The capacitor has to be removed after alignment. No permanent connection must be made to test point 3, otherwise the tuner may exceed the oscillator radiation limits.

MEASURING METHOD OF POWER GAIN

The i.f. output of the tuner should be measured with the circuit given in Fig. 19. The terminals 7, 9 and 11 should be not connected.

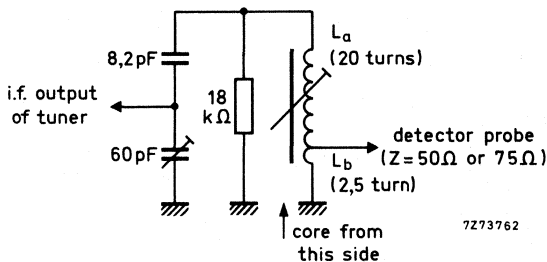

Fig. 19.

Switch the tuner to the v.h.f. III band; the tuning voltage should be 15 to 20 V. Feed an i.f. sweep signal (e.m.f. 500 to 1000 mV) to test point 1 as given in Alignment of the i.f. circuit. Adjust the trimmer (Fig. 19), tunable coil (L_a/L_b), i.f. output coil of the tuner L519 (Fig. 1) and the coupling between L_a and L_b to get the resonant curve as given in Fig. 20.

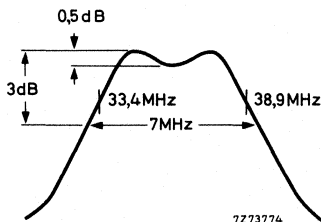

Fig. 20.

Then display the r.f. + i.f. curve of the tuner at 190 MHz (picture carrier frequency) and make small corrections in the alignment of the i.f. coils (L_a/L_b and L519), if necessary, to get the 38,9 MHz and 33,4 MHz markers symmetrically on the slopes of the curve and the peaks at equal amplitude.

Because the output impedance of the dummy circuit is 50 to 75 Ω , the power gain can be measured in the conventional manner by inserting tuner and dummy circuit between a 75 Ω source and a 75 Ω detector (or between a 50 Ω source and matching pad 50/75 Ω and a 50 Ω detector).

ACCESSORIES

Aerial input transformer ELC1094, v.h.f., catalogue number: 2422 542 10941.

Aerial input transformer ELC2092, u.h.f., catalogue number: 2422 542 12921.

Coaxial aerial input assembly, with safety capacitors, catalogue number: 3122 127 10450.

Coaxial aerial input assembly, without safety capacitors, catalogue number: 3122 128 57720.



V.H.F./U.H.F. TELEVISION TUNER

with diode tuning

QUICK REFERENCE DATA

Systems	C. C. I. R. systems B and G
Channels ¹⁾	0 to 4 (low v. h. f. band) 5 to 11 (high v. h. f. band) 28 to 63 (u. h. f. band)
Intermediate frequencies	
picture	36, 875 MHz
sound	31, 375 MHz

APPLICATION

Designed to cover the Australian v. h. f. and u. h. f. channels of C. C. I. R. systems B and G.



¹⁾ In accordance with the publications of the Australian Broadcasting Control Board (ABCB).

DESCRIPTION

The ELC2060 is a combined v.h.f./u.h.f. tuner with electronic tuning and band switching, covering the low v.h.f. band with the channels 0 to 4 (frequency range 45 to 101 MHz), the high v.h.f. band with the channels 5 to 11 (frequency range 101 to 222 MHz), and the u.h.f. band with the channels 28 to 63 (frequency range 526 to 814 MHz).

Mechanically, the tuner is built on a low-loss printed-wiring board, carrying all components, in a metal housing made of a rectangular frame and front and rear cover (see Fig. 2). The two aerial connections (v.h.f. and u.h.f.) are on the two frame sides, all other connections (supply voltages, a.g.c. voltage, tuning and switching voltages) are made via feed-through capacitors in the under side. The mounting method is shown in Figs. 3 and 4.

Electrically, the tuner consists of v.h.f. and u.h.f. parts. The v.h.f. aerial signal is fed via an i.f. trap, combined with a high-pass filter, to a tuned input circuit, which is connected to the emitter of the input transistor BF200. The collector load of this transistor is formed by a double tuned circuit, transferring the signal to the base of the mixer transistor BF183. The oscillator is equipped with a transistor BF494. The four r.f. circuits are tuned by four capacitance diodes BB109G. A capacitance diode BB106 provides a frequency-dependent coupling of the r.f. input signal to the tuned input circuit. Switching between the low and high v.h.f. bands is done by four switching diodes (BA182, BA243, and BA244).

The collector circuit of the mixer transistor is a single tuned i.f. resonant circuit, at the low end of which the i.f. signal is capacitively coupled out of the tuner (low capacitance coupling). An i.f. injection point is provided at the collector of the mixer, for aligning this circuit together with the i.f. amplifier of the television receiver.

The u.h.f. part of the tuner consists of a tuned input circuit, connected to the emitter of the amplifier transistor BF183. The inter-stage network between this transistor and the self-oscillating mixer stage is formed by a double tuned circuit. A transistor BF181 acts as a self-oscillating mixer. The four tuned u.h.f. circuits are tuned by four capacitance diodes BB105B.

The output of the self-oscillating mixer is fed to a double tuned i.f. circuit which is connected to the emitter of the v.h.f. mixer transistor BF183, now operating as an i.f. amplifier in grounded-base configuration. Band switching between v.h.f. and u.h.f. is achieved by a diode BA243.

The tuner requires transistor supply voltages of +12 V, a switching voltage of +12 V, a.g.c. voltages, variable from +2,4 V (normal operating point) to about +7,5 V (maximum a.g.c.) and a tuning voltage, variable from +0,5 V to +28 V.

The aerial inputs of the tuner are asymmetrical. For use in symmetrical aerial systems, aerial transformers (baluns) are available (see ACCESSORIES).

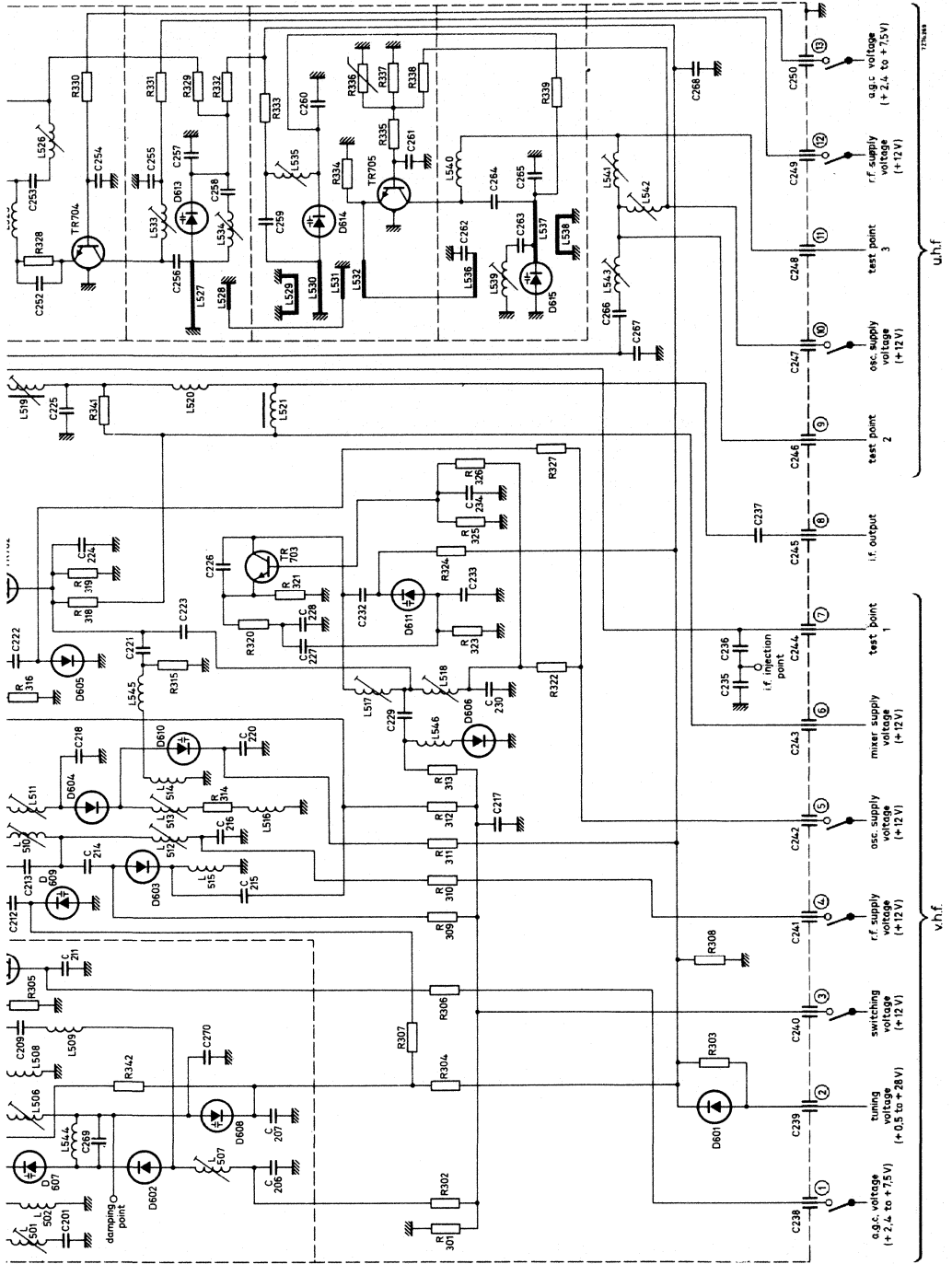

MECHANICAL DATA

Dimensions in mm

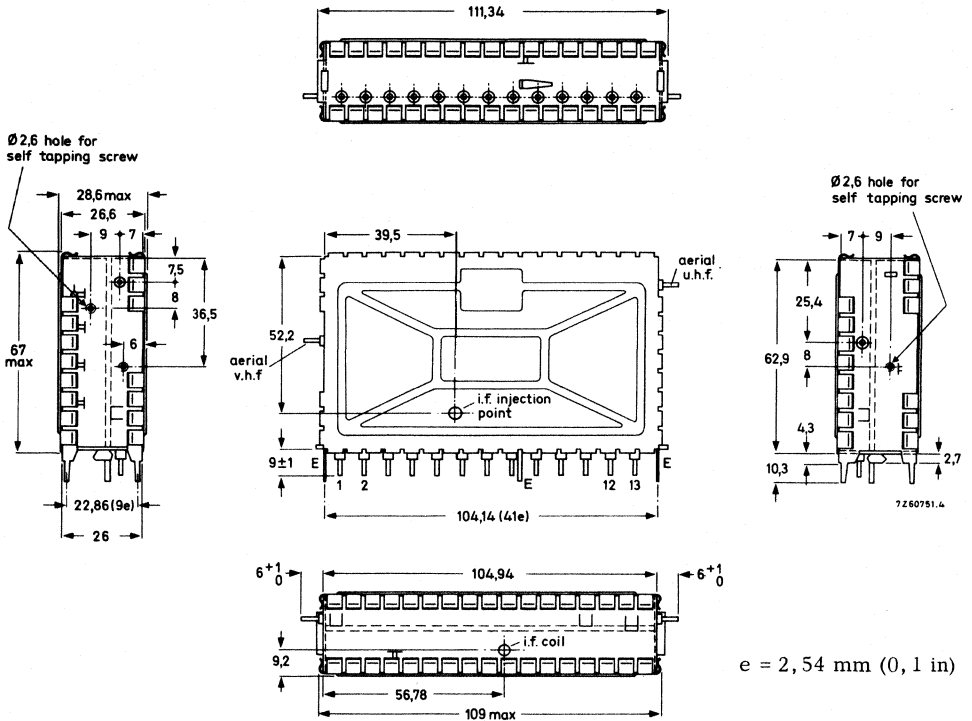

e = 2,54 mm (0, 1 in)

Fig. 2.

- Terminal 1 = a. g. c. voltage, v. h. f. , +2,4 to +7,5 V
- 2 = tuning voltage, +0,5 to +28 V
- 3 = switching voltage, +12 V (approx. 22 mA)
- 4 = r. f. supply voltage, v. h. f. , +12 V (approx. 3 to 10 mA)
- 5 = oscillator supply voltage, v. h. f. , +12 V (approx. 6 mA)
- 6 = mixer supply voltage, v. h. f. , +12 V (approx. 5 mA)
- 7 = test point 1, v. h. f.
- 8 = i. f. output
- 9 = test point 2 (alignment short)
- 10 = oscillator supply voltage, u. h. f. , +12 V (approx. 4, 8 mA)
- 11 = test point 3, u. h. f.
- 12 = r. f. supply voltage, u. h. f. , +12 V (approx. 2,5 to 9,5 mA)
- 13 = a. g. c. voltage, u. h. f. , +2,4 to +7,5 V
- E = earth

Mounting

The tuner may be mounted by soldering it on to a printed-wiring board, using the piercing diagram shown in Fig. 3. (The tuner may also be mounted by means of a snap-in mount or a bracket. Information will be supplied upon request.)
The tuner may be mounted anywhere in the receiver and there are no restrictions on orientation.

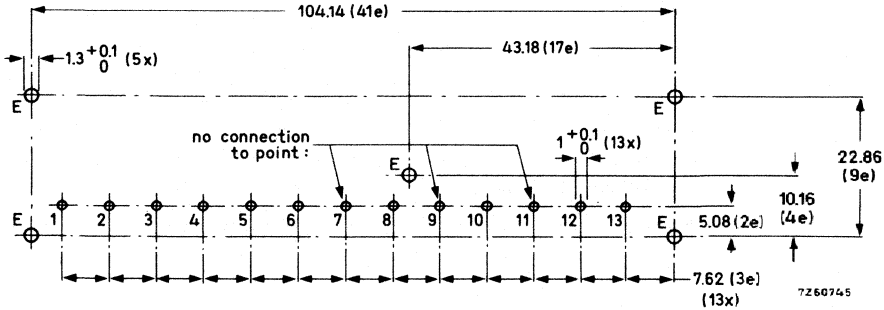

Fig. 3. Piercing diagram viewed from solder side of board; e = 2,54 mm (0,1 in).
No connection must be made to the points 7, 9 and 11, otherwise the oscillator radiation may increase.

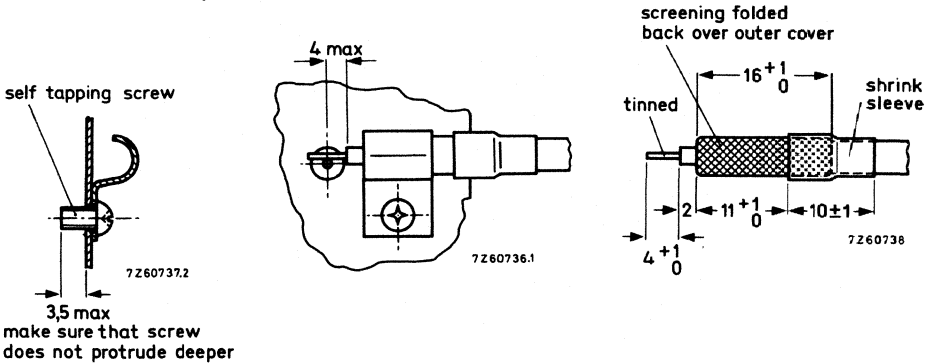

Fig. 4. Recommended fixing method of the aerial cables. Use a self-tapping screw.

ELECTRICAL DATA

Unless otherwise specified all electrical values apply at an ambient temperature of 25 ± 5 °C and a supply voltage of $12 \pm 0,3$ V.

Semiconductors

v. h. f. bands, r. f. amplifier	BF200
mixer	BF183
oscillator	BF494
tuning diodes	4 x BB109G
coupling diode	BB106
switching diodes	2 x BA182; 1 x BA243; 2 x BA244
u. h. f. band, r. f. amplifier	BF180
mixer/oscillator	BF181
tuning diodes	4 x BB105B
drift compensating diode	BAW62

Ambient temperature range

operating	+5 to +55 °C
storage	-25 to +85 °C

Relative humidity

max. 90%

Supply voltage

+12 V +10%, -15%

Current drawn from +12 V supply

low v. h. f. band	14 to 21 mA	} depending on a. g. c. voltage
high v. h. f. band	36 to 43 mA	
u. h. f. band	33,5 to 40 mA	

A. G. C. voltage (Figs. 5, 6 and 7)

low v. h. f. band, at nominal gain	2,4 V
at 40 dB gain reduction	typ. 5,5 V
high v. h. f. band, at nominal gain	2,4 V
at 40 dB gain reduction	typ. 4,5 V
u. h. f. band, at nominal gain	2,4 V
at 30 dB gain reduction	typ. 5,0 V

A. G. C. current

low v. h. f. band	} at 40 dB gain reduction	max. 0,8 mA
high v. h. f. band		max. 0,6 mA
u. h. f. band, at 30 dB gain reduction		max. 0,7 mA

Tuning voltage range (Figs. 8, 9 and 10)

+0,5 to +28 V

Current drawn from 28 V tuning voltage supplymax. 36 μ A

Note: The source impedance of the tuning voltage offered to terminal 2, must be max. 30 k Ω at tuning voltages below 2 V.

Switching voltage

low v. h. f. band	open circuit
high v. h. f. band	+12 V
u. h. f. band	+12 V

Note: In the low v. h. f. band position, the tuner produces a negative voltage (1 to 5 V) at terminal 3; this terminal must not be loaded with an external resistance below 20 M Ω .

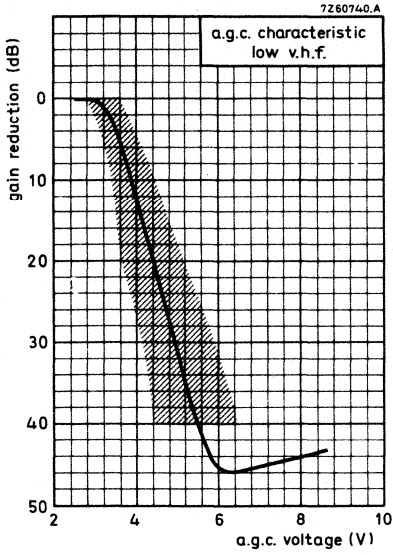

Fig. 5

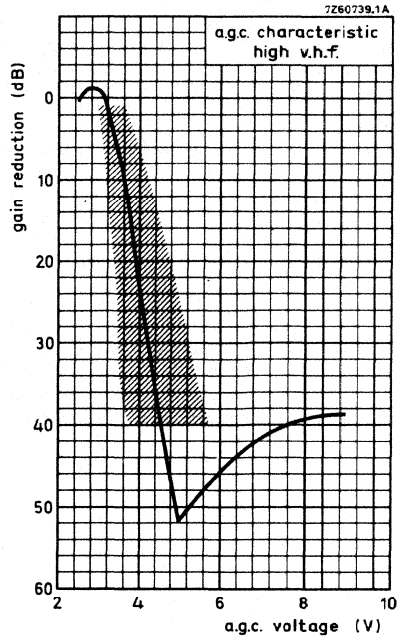

Fig. 6.

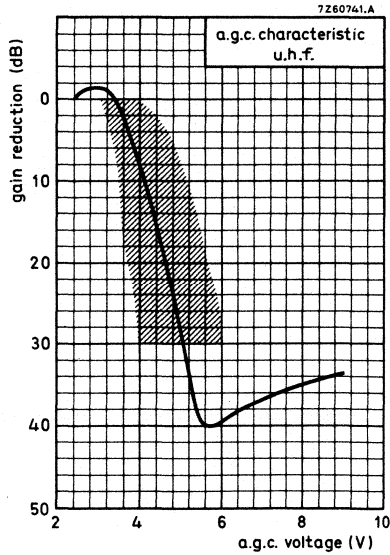

Fig. 7.



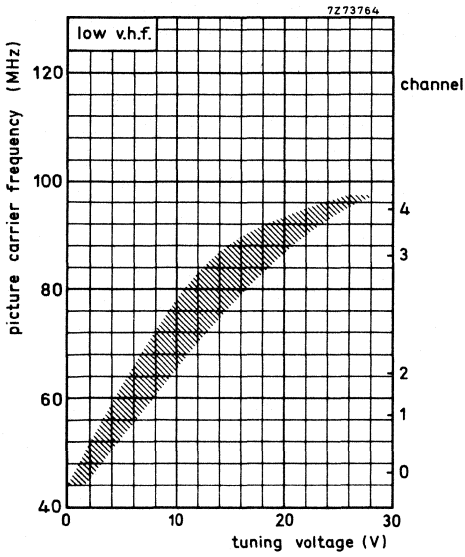

Fig. 8.

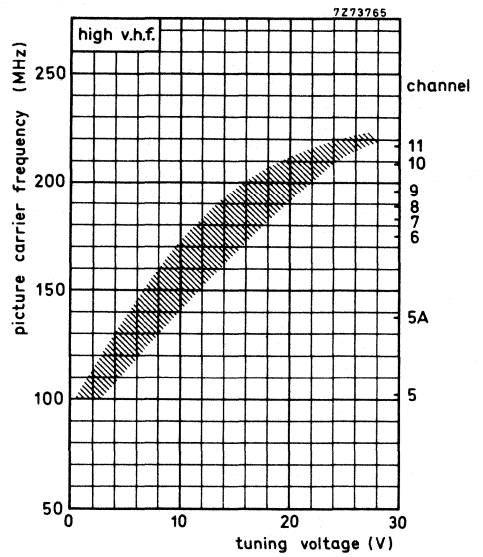

Fig. 9.

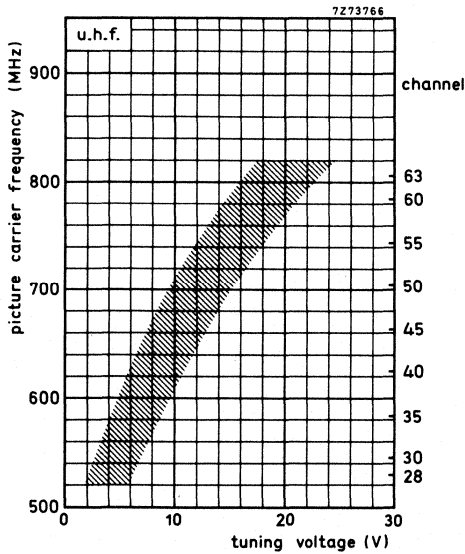

Fig. 10.

Frequency ranges				
low v. h. f. band		channel 0 (picture carrier 46,25 MHz)		
		to channel 4 (picture carrier 95,25 MHz).		
		Margin at the extreme channels : min.		
		1,5 MHz.		
high v. h. f. band		channel 5 (picture carrier 102,25 MHz)		
		to channel 11 (picture carrier 216,25 MHz).		
		Margin at the extreme channels : min.		
		2 MHz.		
u. h. f. band		channel 28 (picture carrier 527,25 MHz)		
		to channel 63 (picture carrier 807,25 MHz).		
		Margin at the extreme channels : min.		
		3 MHz.		
Intermediate frequencies				
picture		36,875 MHz		
sound		31,375 MHz		
		The oscillator frequency is higher than the		
		input-signal frequency.		
Input impedance				
asymmetrical		75 Ω		
symmetrical		300 Ω (see ACCESSORIES)		
V. S. W. R. (between picture carrier and sound carrier)		v. s. w. r. at nom. gain	max. v. s. w. r. during gain control	
		min. 1) max. 2)	min. 1 max. 2)	
low v. h. f. band		max. 3 max. 5	max. 4 max. 5,5	
high v. h. f. band, channels 5A to 11 channel 5		max. 4 max. 5	max. 4,5 max. 5,5	
		max. 4 max. 6	max. 4,5 max. 6	
u. h. f. band		max. 4	max. 5	
A. G. C. range				
low v. h. f. band		min. 40 dB		
high v. h. f. band		min. 40 dB		
u. h. f. band		min. 30 dB		

1) Best value of V. S. W. R. between picture carrier and sound carrier.

2) Worst value of V. S. W. R. between picture carrier and sound carrier.

R. F. curves at nominal gain		
bandwidth, low v. h. f. band		typ. 9 to 13 MHz
high v. h. f. band		typ. 9 to 14 MHz
u. h. f. band		typ. 13 to 18 MHz
tilt, low v. h. f. band		max. 3 dB
high v. h. f. band, channels 5 and 5A		max. 3,5 dB
channels 6 to 11		max. 3 dB
u. h. f. band		max. 3 dB
Power gain (see also MEASURING METHODS)		
v. h. f. bands, except channel 5		min. 25 dB
channel 5		min. 21 dB
channel 0		typ. 31 dB
channel 4		typ. 29 dB
channel 5		typ. 24 dB
channel 8		typ. 29 dB
u. h. f. band		min. 25 dB
channel 28		typ. 30 dB
channel 63		typ. 32 dB
Noise figure		
low v. h. f. band		max. 9 dB
channel 0		typ. 7 dB
channel 4		typ. 7 dB
high v. h. f. band		
channel 5		max. 11 dB
		typ. 9 dB
channel 5A		max. 8,5 dB
		typ. 6,5 dB
channels 6 to 11		max. 8 dB
		typ. 5 dB
u. h. f. band		max. 12 dB
channel 28		typ. 8,5 dB
channel 63		typ. 9,5 dB
I. F. rejection		
v. h. f. bands, channel 0		min. 40 dB
channels 1 and 2		min. 50 dB
channels 3 to 11		min. 60 dB
u. h. f. band		min. 60 dB
Image rejection		
low v. h. f. band		min. 50 dB
high v. h. f. band		min. 60 dB
u. h. f. band		min. 40 dB

Signal handling (see also Figs. 12 and 13)

Minimum input signal (e. m. f.) producing
cross-modulation (1%) at nominal
gain, in channel

(wanted signal: picture carrier frequency,
interfering channel: sound carrier
frequency), low v. h. f. band
high v. h. f. band
u. h. f. band

typ. 4 mV
typ. 4 mV
typ. 5 to 10 mV } 1)

in band

(wanted signal: picture carrier frequency
of channel N,
interfering signal: picture carrier of
channel N-2 (v. h. f.), N-5 (u. h. f.))

low v. h. f. band
high v. h. f. band
u. h. f. band

typ. 15 to 60 mV
typ. 10 to 50 mV
typ. 15 to 50 mV } 1)

Minimum input signal (e. m. f.) producing
overloading, at nominal gain
at maximum a. g. c.

typ. 10 mV
typ. >200 mV } 2)

Minimum input signal (e. m. f.) at nominal
gain producing a shift of the oscillator
frequency of 10 kHz, low v. h. f. band
high v. h. f. band
u. h. f. band

typ. 25 mV
typ. 25 mV
typ. 10 to 20 mV } 3)

Tuning range of the i. f. output circuit (see
also MEASURING METHODS)

max. 31,5 to min. 37,5 MHz

Detuning of the i. f. output circuit as a result of
band switching and tuning with respect of channel 8

max. 400 kHz

Shift of oscillator frequency

at a change of the supply voltage of 10%

v. h. f. bands, channels 0 to 4
channels 5 to 11

max. 500 kHz
max. 300 kHz
max. 600 kHz

u. h. f. band

at a gain reduction of 30 dB

max. 100 kHz

1) This e. m. f. (open voltage) is referred to an impedance of 75 Ω .

1% cross-modulation means that 1% of the modulation depth of the interfering signal is transferred to the wanted signal.

2) This e. m. f. (open voltage) is referred to an impedance of 75 Ω .

Criterion of overloading: 30% compression of the synchronization pulses of a standard television signal or a noticeable deterioration of the picture quality.

3) This e. m. f. (open voltage) is referred to an impedance of 75 Ω .

Drift of oscillator frequency

during warm-up time (measured between 5 s and 15 min after switching on)

v. h. f. bands	max. 200 kHz
u. h. f. band	max. 250 kHz

at a change of the ambient temperature from 25 to 50 °C

v. h. f. bands	max. 500 kHz
u. h. f. band	max. 1000 kHz

Oscillator radiation

The tuner is in conformity with the radiation requirements of the Australian Standard AS 1053-1973 and of C.I.S.P.R. Recommendation No. 24/3, provided the following conditions are fulfilled:

- A low-pass filter (Fig. 11) with a cut-off frequency of about 300 MHz has to be inserted between the v. h. f. aerial terminal of the tuner and the aerial terminal of the receiver. Television receivers with a common v. h. f. /u. h. f. connector in combination with a low-pass/high-pass splitter ¹⁾ may not need this additional filter.

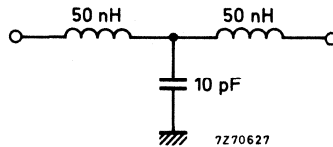

Fig. 11.

- No connections must be made to the terminals 7, 9 and 11.
- Earthing of the tuner and connections to the i. f. amplifier have to be made in such a way, that additional radiation is prevented.

Microphonics

If the tuner is installed in a professional manner, there will be no microphonics.

¹⁾ E. g. coaxial aerial input assembly 3122 127 10450.

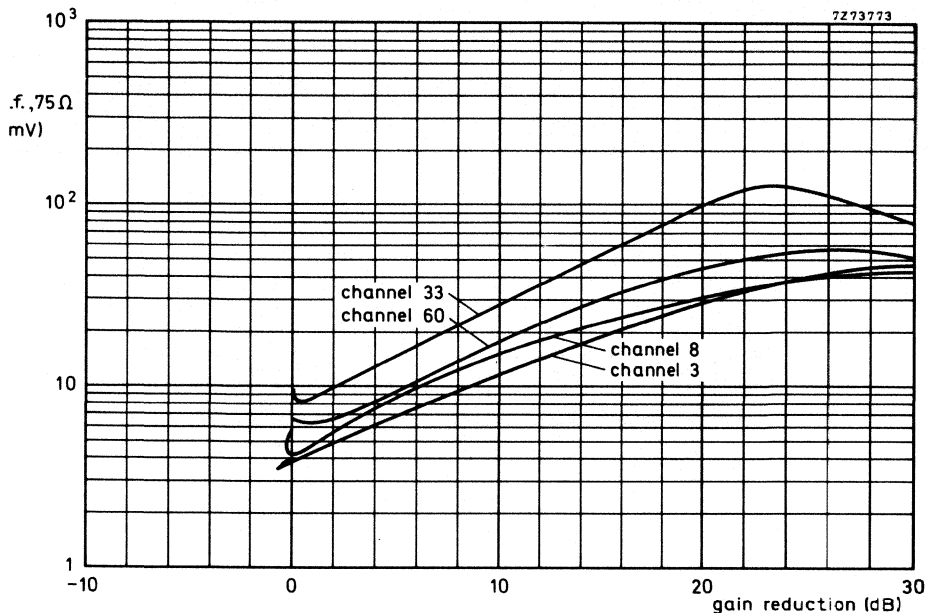

Fig. 12. Cross-modulation, in channel.

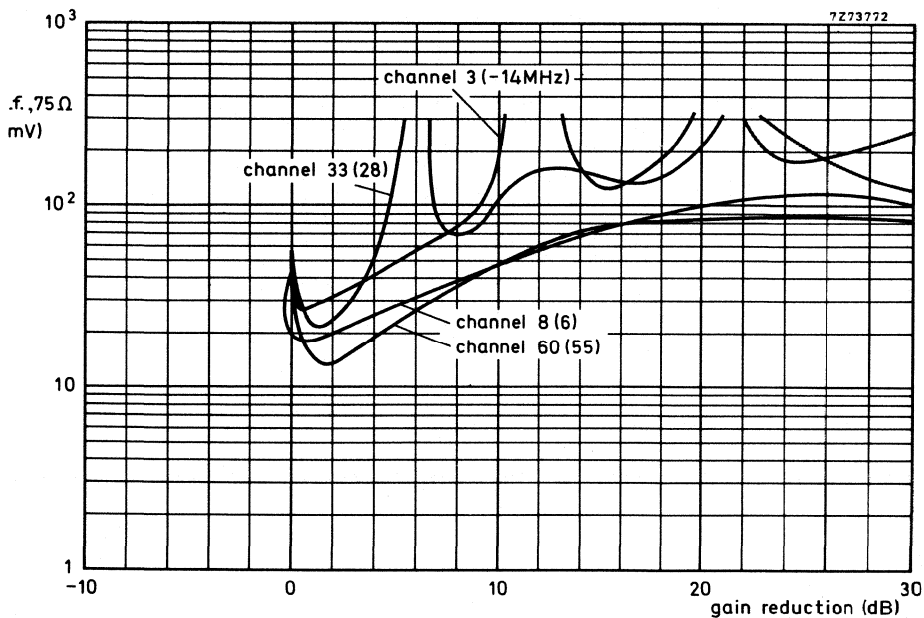

Fig. 13. Cross-modulation, in band; the interfering channels are given between brackets.

APPLICATION INFORMATION

Connection of the tuner

For connection of the tuner the terminal location, Fig. 2, should be consulted. If the tuner is used in receivers the chassis of which is connected to the mains, isolating capacitors according to the safety rules have to be inserted in the aerial leads. Five ways of connecting, depending on the number of switches available, are given below.

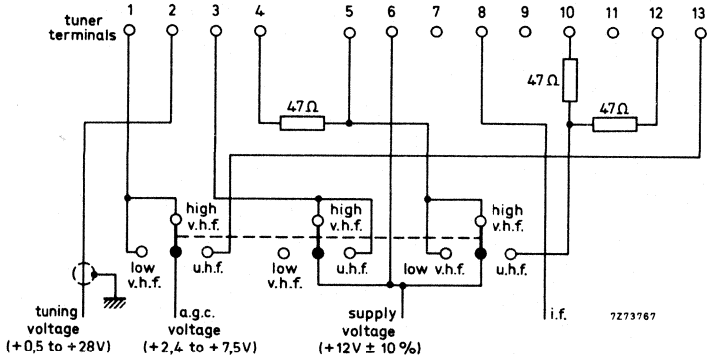

Fig. 14. Connection diagram with three switches.

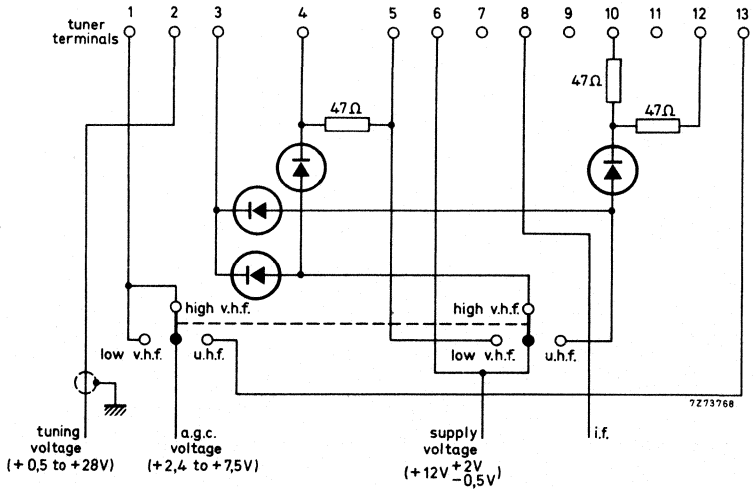

Fig. 15. Connection diagram with two switches.

All diodes : BAX13, BA217 or comparable silicon diodes.

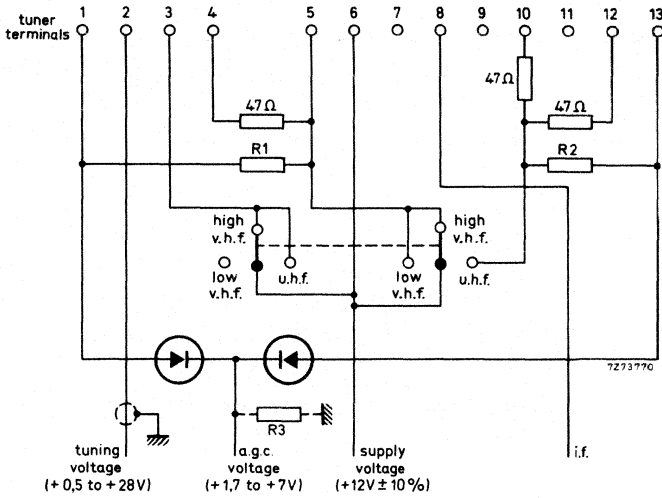

Fig. 16. Connection diagram with two switches.
All diodes: BAX13, BA217 or comparable silicon diodes.
The values of R_1 , R_2 and R_3 depend on a.g.c. circuit.

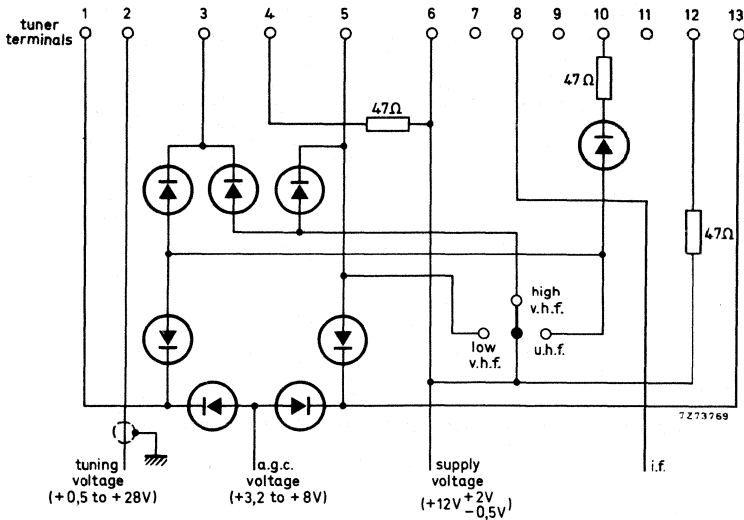

Fig. 17. Connection diagram with one switch.
All diodes: BAX13, BA217 or comparable silicon diodes.

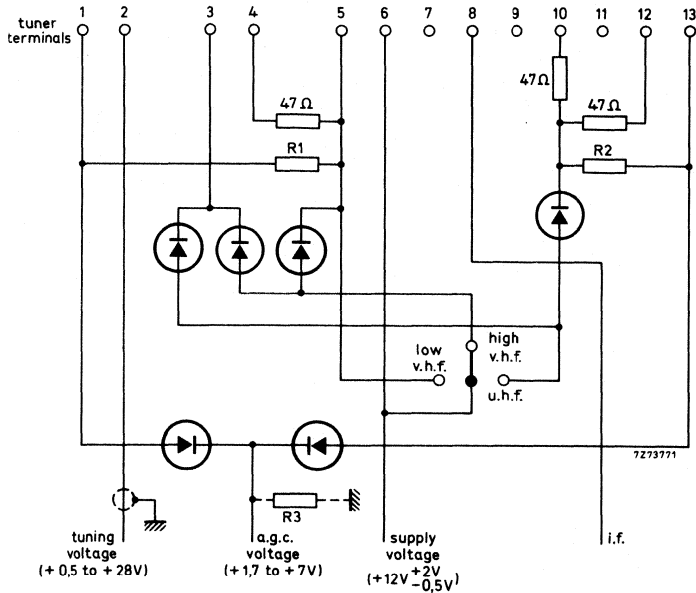

Fig. 18. Connection diagram with one switch.

All diodes: BAX13, BA217 or comparable silicon diodes.
The values of R_1 , R_2 and R_3 depend on a.g.c. circuit.

Alignment of the i. f. circuit

The tuner is provided with an i. f. injection point at the collector of the mixer for aligning the i. f. circuit together with the i. f. amplifier of the television receiver (for the position of the i. f. injection point see Fig. 2).

The alignment should be done with the high v. h. f. band tuned. The tuning voltage should be 15 to 20 V.

If this injection method cannot be employed in the television receiver (e. g. because the injection point is not accessible or there is not enough i. f. signal available), the i. f. signal can be fed to test point 3 (terminal 11) via a capacitor of 0,82 to 1 pF. The tuner must be switched to the u. h. f. position; the tuning voltage should be approx. 10 V. This injection method requires approx. 14 dB less signal than the first method. No permanent connection must be made to test point 3, otherwise the tuner may exceed the oscillator radiation limits.

MEASURING METHODSPower gain

The i. f. output of the tuner should be terminated with the dummy circuit given below. The terminals 7, 9 and 11 should be not connected.

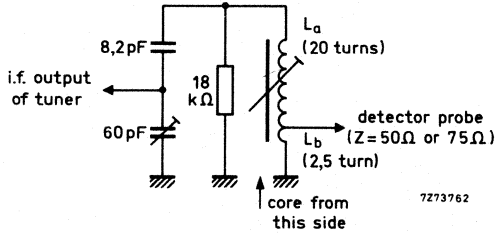

Fig. 19.

The dummy circuit should be aligned as follows.

Switch the tuner to the high v. h. f. band; the tuning voltage should be 15 to 20 V.

Feed an i. f. sweep signal (500 to 1000 mV) to the i. f. injection point.

Adjust the trimmer (Fig. 19), tunable coil (L_a/L_b), i. f. output coil of the tuner L519 (Fig. 1) and the coupling between L_a and L_b to get the resonant curve as given below.

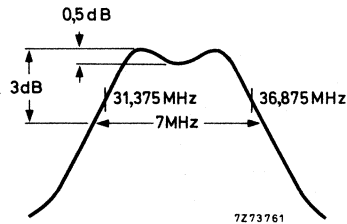

Fig. 20.

Then display the r. f. + i. f. curve of the tuner at 190 MHz (picture carrier frequency) and make small corrections in the alignment of the i. f. coils (L_a/L_b and L519), if necessary, to get the markers 36, 875 MHz and 31, 375 MHz symmetrically on the slopes of the curve, and the peaks at equal amplitude.

Because the output impedance of the dummy circuit is 50 to 75 Ω , the power gain can be measured in the conventional manner by inserting tuner and dummy circuit between a 75 Ω source and a 75 Ω detector (or between a 50 Ω source and matching pad 50/75 Ω and a 50 Ω detector).

Tuning range of i. f. output circuit

The i. f. output of the tuner should be terminated with the circuit given in Fig. 21. The terminals 7, 9 and 11 should not be connected.

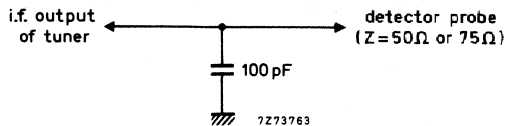

Fig. 21.

ELC2060

V.H.F. /U.H.F. TELEVISION TUNER
with diode tuning

3122 128 56991

ACCESSORIES

Aerial input transformer ELC1094, v.h.f. , catalogue number : 2422 542 10941;
aerial input transformer ELC2092, u.h.f. , catalogue number : 2422 542 12921;
coaxial aerial input assembly, catalogue number : 3122 127 10450.



V.H.F./U.H.F. TELEVISION TUNER

with diode tuning

QUICK REFERENCE DATA

System	C.C.I.R. system I
Channels (South African channel distribution)	4 to 13 (v.h.f. band) 21 to 69 (u.h.f. band)
Intermediate frequencies	
picture	38,9 MHz
sound	32,9 MHz

APPLICATION

Designed to cover the South African v.h.f. and u.h.f. channels of C.C.I.R. system I.



DESCRIPTION

The ELC2070 is a combined v. h. f. /u. h. f. tuner with electronic tuning and band switching, covering the South African v. h. f. band (frequency range 174 to 254 MHz) and the u. h. f. band (frequency range 470 to 860 MHz).

Mechanically, the tuner is built on a low-loss printed-wiring board, carrying all components, in a metal housing made of a rectangular frame and front and rear cover (see Fig. 2). The two aerial connections (v. h. f. and u. h. f.) are on the two frame sides, all other connections (supply voltages, a. g. c. voltage and tuning voltage) are made via feed-through capacitors in the under side. The mounting method is shown in Figs. 3 and 4.

Electrically, the tuner consists of v. h. f. and u. h. f. parts. The v. h. f. aerial signal is fed via an i. f. trap, combined with a high-pass filter, to a tuned input circuit, which is connected to the emitter of the input transistor BF200. The collector load of this transistor is formed by a double tuned circuit, transferring the signal to the base of the mixer transistor BF182. The oscillator is equipped with a transistor BF494. The four r. f. circuits are tuned by four capacitance diodes BB106.

The collector circuit of the mixer transistor is a single tuned i. f. resonant circuit, at the low end of which the i. f. signal is capacitively coupled out of the tuner. An i. f. injection point is provided at the collector of the mixer, for aligning this circuit together with the i. f. amplifier of the television receiver.

The u. h. f. part of the tuner consists of a tuned input circuit, connected to the emitter of the amplifier transistor BF180. The inter-stage network between this transistor and the self-oscillating mixer stage is formed by a double tuned circuit. A transistor BF181 acts as a self-oscillating mixer. The four tuned u. h. f. circuits are tuned by four capacitance diodes BB105B.

The output of the self-oscillating mixer is fed to a double tuned i. f. circuit which is connected to the emitter of the v. h. f. mixer transistor BF182, now operating as an i. f. amplifier in grounded-base configuration. Band switching between v. h. f. and u. h. f. is achieved by a diode BA243.

The tuner requires transistor supply voltages of +12 V, a. g. c. voltages, variable from +2,4 V (normal operating point) to about +7,5 V (maximum a. g. c.), and a tuning voltage, variable from +0,5 V to +28 V.

The aerial inputs of the tuner are asymmetrical. For use in symmetrical aerial systems, aerial transformers (baluns) are available (see ACCESSORIES).

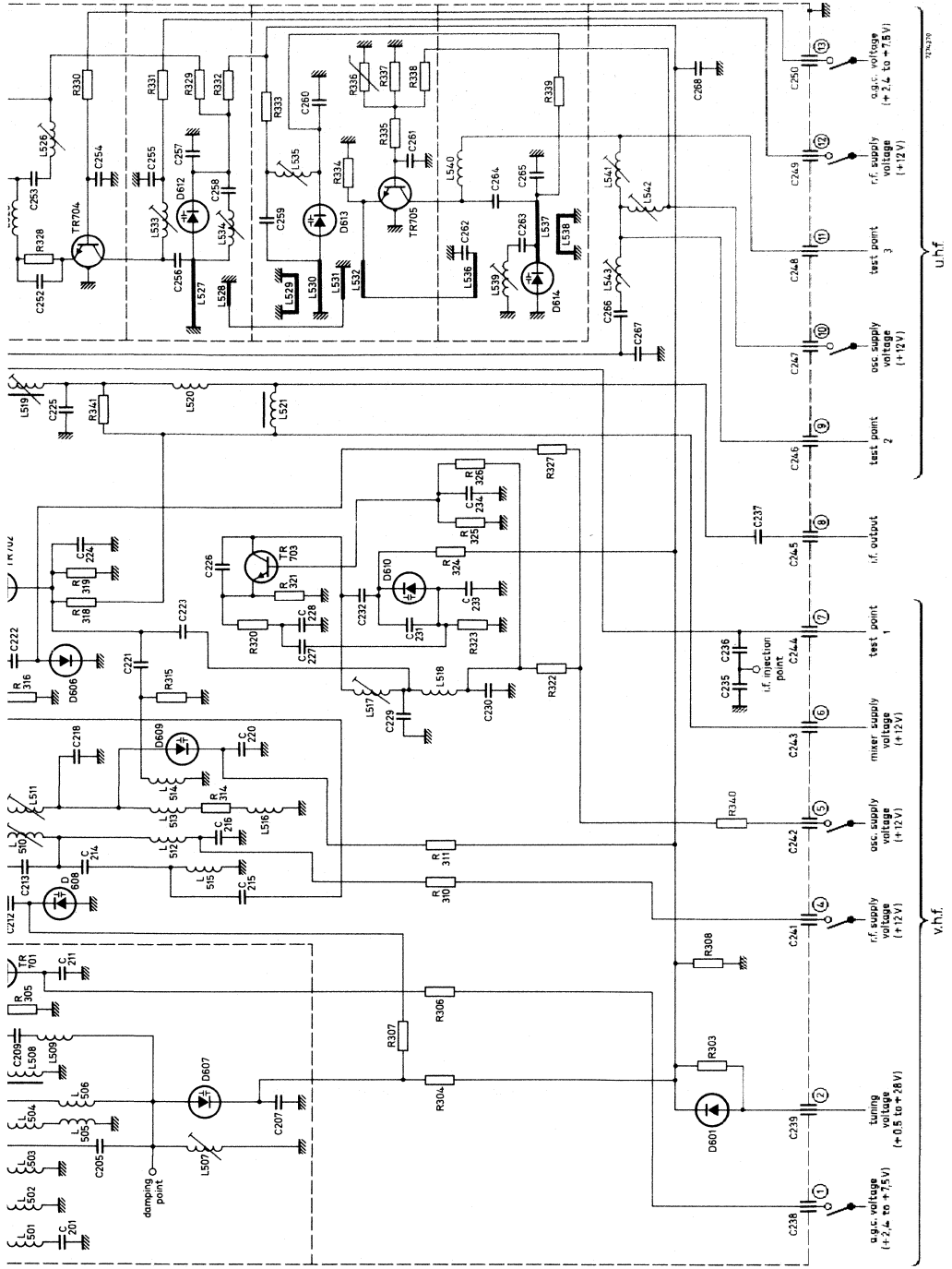

MECHANICAL DATA

Dimensions in mm

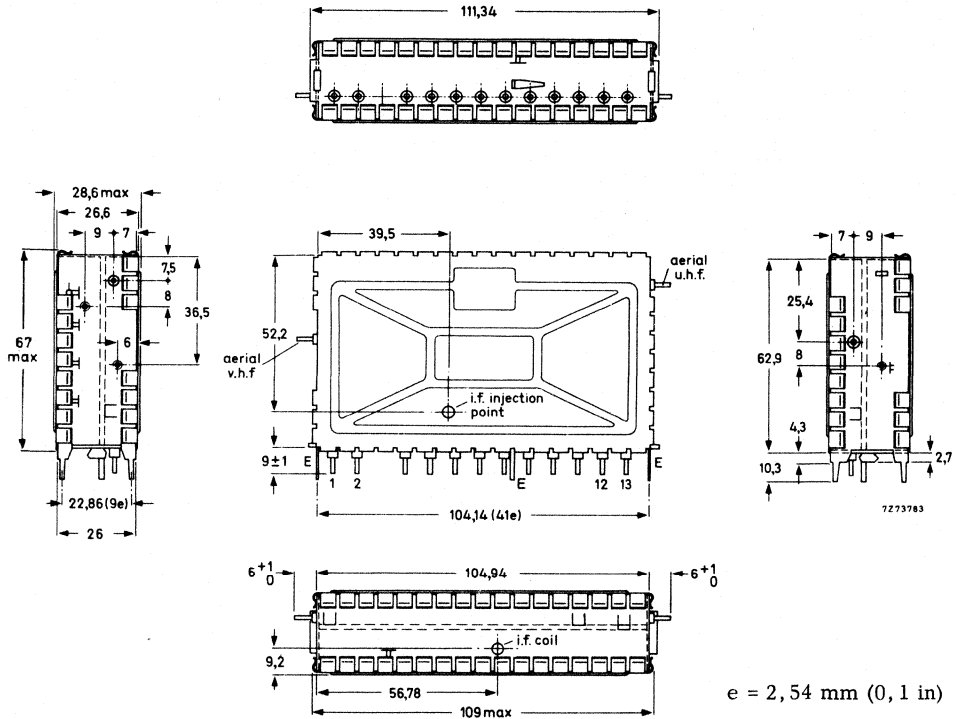

e = 2,54 mm (0,1 in)

Fig. 2

- Terminal 1 = a. g. c. voltage, v. h. f. , +2,4 to +7,5 V
- 2 = tuning voltage, +0,5 to +28 V
- 4 = r. f. supply voltage, v. h. f. , +12 V (approx. 3 to 10 mA)
- 5 = oscillator supply voltage, v. h. f. , +12 V (approx. 6 mA)
- 6 = mixer supply voltage, v. h. f. , +12 V (approx. 5 mA)
- 7 = test point 1, v. h. f.
- 8 = i. f. output
- 9 = test point 2 (alignment short)
- 10 = oscillator supply voltage, u. h. f. , +12 V (approx. 4,1 mA)
- 11 = test point 3, u. h. f.
- 12 = r. f. supply voltage, u. h. f. , +12 V (approx. 2,5 to 9,5 mA)
- 13 = a. g. c. voltage, u. h. f. , +2,4 to +7,5 V
- E = earth

Mounting

The tuner may be mounted by soldering it on to a printed-wiring board, using the piercing diagram shown in Fig. 3. (The tuner may also be mounted by means of a snap-in mount or a bracket. Information will be supplied upon request.)
The tuner may be mounted anywhere in the receiver and there are no restrictions on orientation.

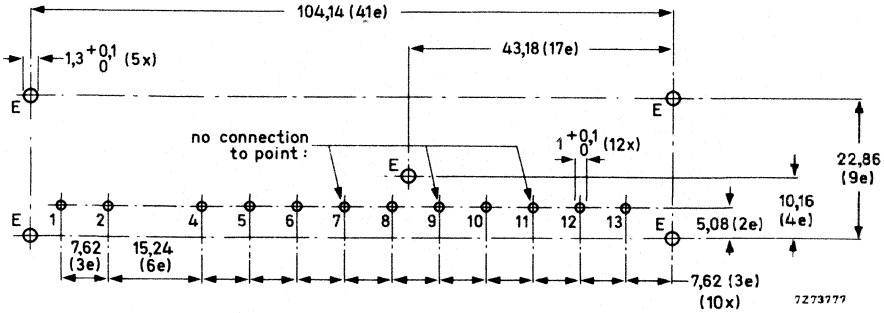

Fig. 3. Piercing diagram viewed from solder side of board; e = 2,54 mm (0,1 in).
No connection must be made to the points 7, 9 and 11, otherwise the oscillator radiation may increase.

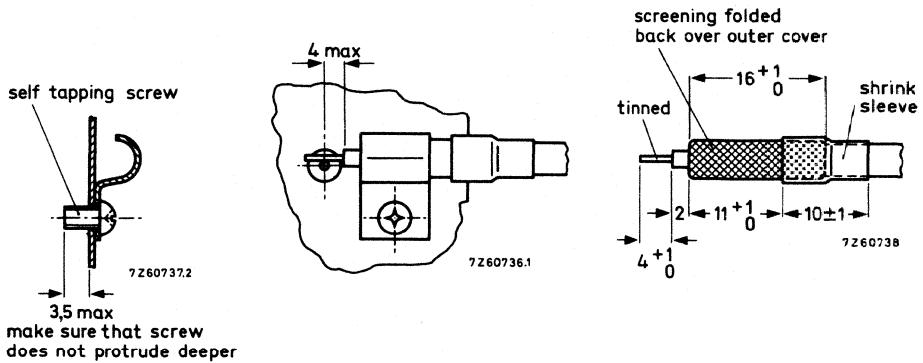

Fig. 4. Recommended fixing method of the aerial cables. Use a self-tapping screw.



ELECTRICAL DATA

Unless otherwise specified all electrical values apply at an ambient temperature of 25 ± 5 °C and a supply voltage of $12 \pm 0,3$ V.

Semiconductors

v. h. f. band, r. f. amplifier	BF200
mixer	BF182
oscillator	BF494
tuning diodes	4 x BB106
switching diode	BA243
u. h. f. band, r. f. amplifier	BF180
mixer/oscillator	BF181
tuning diodes	4 x BB105B
drift compensating diode	BAW62

Ambient temperature range

operating	+5 to +55 °C
storage	-25 to +85 °C

Supply voltage

Current drawn from +12 V supply

v. h. f. band	14 to 21 mA	} depending on a. g. c. voltage
u. h. f. band	11,5 to 18 mA	

A. G. C. voltage (Figs. 5 and 6)

v. h. f. band, at nominal gain	2,4 V
at 40 dB gain reduction	typ. 4,5 V
u. h. f. band, at nominal gain	2,4 V
at 30 dB gain reduction	typ. 5,0 V

A. G. C. current

v. h. f. band, at 40 dB gain reduction	max. 0,6 mA
u. h. f. band, at 30 dB gain reduction	max. 0,7 mA

Tuning voltage range (Fig. 7 and 8)

Current drawn from 28 V tuning voltage supply	+0,5 to +28 V max. 36 µA
--	-----------------------------

Frequency ranges

v. h. f. band	South African channel 4 (picture carrier 175,25 MHz) to channel 13 (picture carrier 247,43 MHz). Margin at the extreme channels : min. 2MHz.
u. h. f. band	channel 21 (picture carrier 471,25 MHz) to channel 69 (picture carrier 855,25 MHz). Margin at the extreme channels : min. 3MHz.

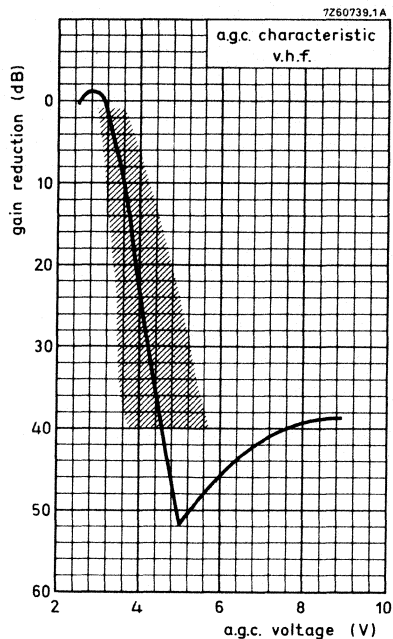

Fig. 5

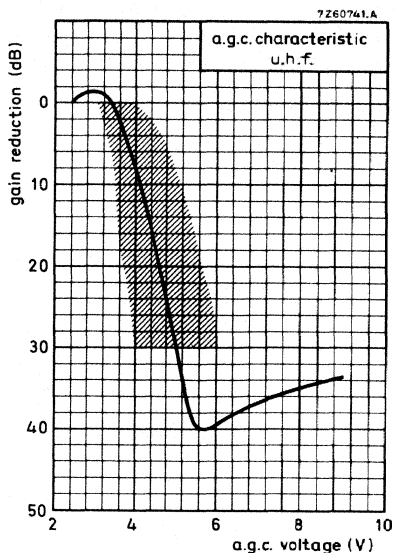

Fig. 6

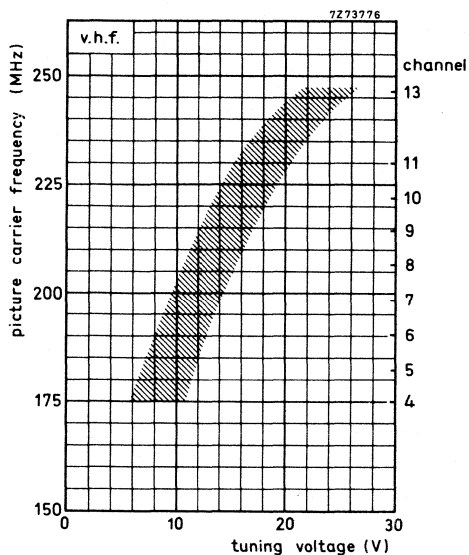

Fig. 7

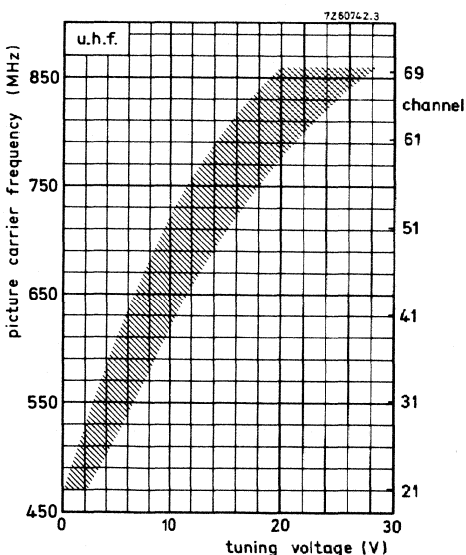

Fig. 8

Intermediate frequencies

picture	38,9 MHz
sound	32,9 MHz

Input impedance

asymmetrical	75 Ω
symmetrical	300 Ω (see ACCESSORIES)

V.S.W.R. (between picture carrier
and sound carrier)

	v. s. w. r. at nom. gain		max. v. s. w. r. during gain control	
	min. 1)	max. 2)	min. 1)	max. 2)
v. h. f. band, channels 4 to 9	max. 3,5	max. 5	max. 4	max. 5
channels 10 to 13	max. 3,5	max. 6	max. 4	max. 6
u. h. f. band		max. 4		max. 5

A.G.C. range

v. h. f. band	min. 40 dB
u. h. f. band	min. 30 dB

R. F. curves

bandwidth, v. h. f. band	typ. 8 to 15 MHz
u. h. f. band	typ. 15 to 25 MHz
tilt, v. h. f. band	max. 3 dB
u. h. f. band, channels 21 to 60	max. 3 dB
channels 61 to 69	max. 4 dB

Power gain (see also MEASURING
METHOD OF POWER GAIN)

v. h. f. band	min. 24 dB
channel 4	typ. 28 dB
channel 13	typ. 27 dB
u. h. f. band	min. 25 dB
channel 21	typ. 32 dB
channel 31	typ. 29 dB
channel 69	typ. 33 dB

Noise figure

v. h. f. band	max. 9 dB
channel 9	typ. 6,5 dB
u. h. f. band	max. 12 dB
channel 21	typ. 8,0 dB
channel 51	typ. 9,5 dB
channel 69	typ. 10,5 dB

1) Best value of V.S.W.R. between picture carrier and sound carrier.

2) Worst value of V.S.W.R. between picture carrier and sound carrier.

I. F. rejection			
v. h. f. band		min. 60 dB	
u. h. f. band		min. 60 dB	
Image rejection			
v. h. f. band		min. 60 dB	
u. h. f. band		min. 40 dB	
Signal handling (see also Figs. 10 and 11)			
Minimum input signal (e. m. f.) producing cross-modulation (1%) at nominal gain, in channel			
(wanted signal: picture carrier frequency, interfering channel: sound carrier frequency), v. h. f. band	typ.	4 mV	} 1)
u. h. f. band	typ.	5 to 10 mV	
in band			
(wanted signal: signal carrier frequency of channel N, interfering signal: picture carrier of channel N-2 (v. h. f.), N-5 (u. h. f.))			
v. h. f. band	typ.	10 to 50 mV	} 1)
u. h. f. band	typ.	15 to 50 mV	
Minimum input signal (e. m. f.) producing overloading, at nominal gain	typ.	10 mV	} 2)
at maximum a. g. c.	typ.	>200 mV	
Minimum input signal (e. m. f.) at nominal gain producing a shift of the oscillator frequency of 10 kHz, v. h. f. band	typ.	>25 mV	} 3)
u. h. f. band	typ.	10 to 20 mV	
Detuning of the i. f. output circuit as a result of band switching and tuning with respect of channel 7		max. 400 kHz	

¹⁾ This e. m. f. (open voltage) is referred to an impedance of 75 Ω.
1% cross-modulation means that 1% of the modulation depth of the interfering signal is transferred to the wanted signal.

²⁾ This e. m. f. (open voltage) is referred to an impedance of 75 Ω.
Criterion of overloading: 30% compression of the synchronization pulses of a standard television signal or a noticeable deterioration of the picture quality.

³⁾ This e. m. f. (open voltage) is referred to an impedance of 75 Ω.

Shift of oscillator frequency

at a change of the supply voltage of 10%

v. h. f. band

max. 300 kHz

u. h. f. band

max. 600 kHz

during warm-up time (measured between 5 s
and 15 min after switching on)

v. h. f. band

max. 100 kHz

u. h. f. band

max. 250 kHz

at a gain reduction of 30 dB

max. 100 kHz

Drift of oscillator frequency

at a change of the ambient temperature
from 25 to 40 °C

v. h. f. band

max. 400 kHz

u. h. f. band

max. 500 kHz

Oscillator radiation

The tuner is in conformity with the radiation requirements of C. I. S. P. R. Recommendation No. 24/3, provided the following conditions are fulfilled:

- A low-pass filter (Fig. 9) with a cut-off frequency of about 300 MHz has to be inserted between the v. h. f. aerial terminal of the tuner and the aerial terminal of the receiver. Television receivers with a common v. h. f. /u. h. f. connector in combination with a low-pass/high-pass splitter ¹⁾ may not need this additional filter.

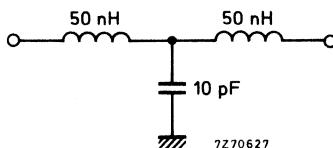

Fig. 9

- No connections must be made to the terminals 7, 9 and 11.
- Earthing of the tuner and connections to the i. f. amplifier have to be made in such a way, that additional radiation is prevented.

Microphonics

If the tuner is installed in a professional manner, there will be no microphonics.

¹⁾ E. g. coaxial aerial input assembly 3122 127 10450.

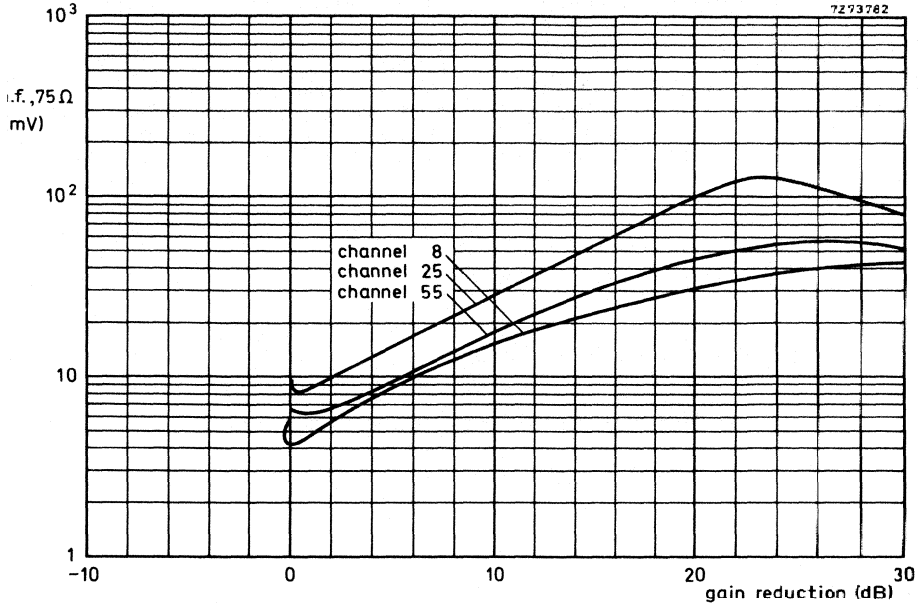

Fig. 10. Cross-modulation, in channel.

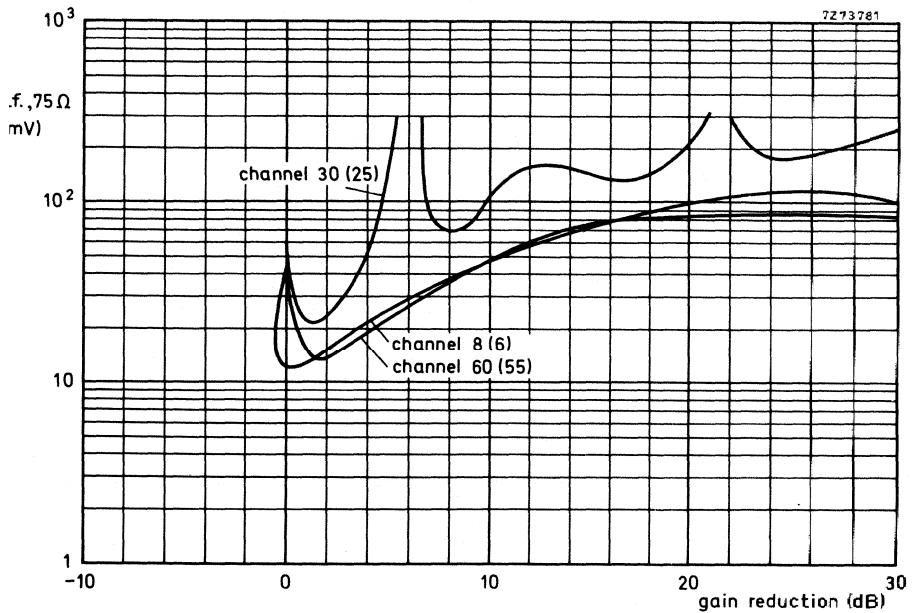

Fig. 11. Cross-modulation, in band; the interfering channels are given between brackets.

APPLICATION INFORMATION

Connection of the tuner

For connection of the tuner the terminal location, Fig. 2, should be consulted. If the tuner is used in receivers the chassis of which is connected to the mains, isolating capacitors according to the safety rules have to be inserted in the aerial leads. Three ways of connecting, depending on the number of switches available, are given below.

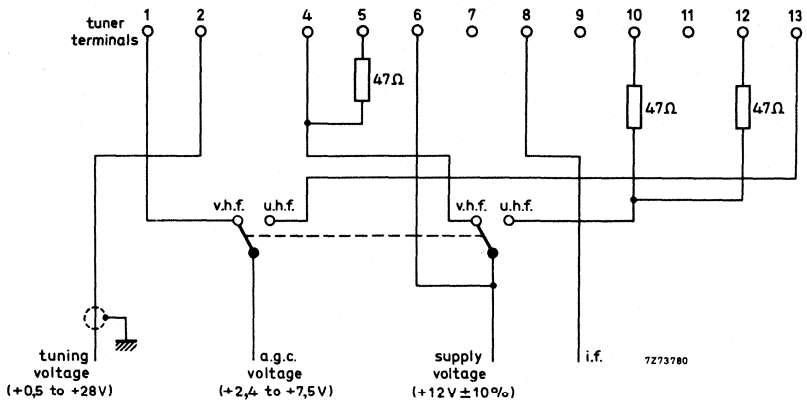

Fig. 12. Connection diagram with two switches.

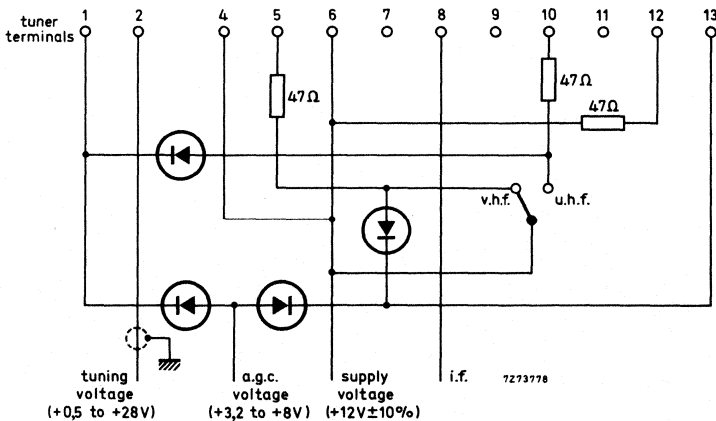

Fig. 13. Connection diagram with one switch.

All diodes: BAX13, BA217 or comparable silicon diodes.

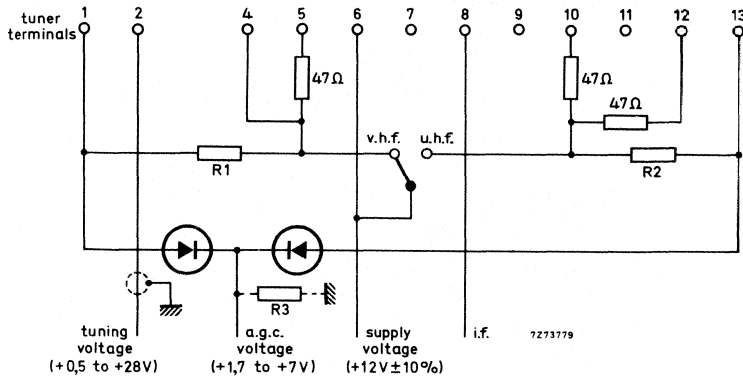

Fig. 14. Connection diagram with one switch.

All diodes : BAX13, BA217 or comparable silicon diodes.

The values of R_1 , R_2 and R_3 depend on a.g.c. circuit.

Alignment of the i. f. circuit

The tuner is provided with an i. f. injection point at the collector of the mixer for aligning the i. f. circuit together with the i. f. amplifier of the television receiver (for the position of the i. f. injection point see Fig. 2).

The aligning should be done with the v. h. f. band tuned. The tuning voltage should be 15 to 20 V.

If this injection method cannot be employed in the television receiver (e. g. because the injection point is not accessible or there is not enough i. f. signal available), the i. f. signal can be fed to test point 3 (terminal 11) via a capacitor of 0, 82 to 1 pF. The tuner must be switched to the u. h. f. position; the tuning voltage should be approx. 10 V.

This injection method requires approx. 14 dB less signal than the first method.

No permanent connection must be made to test point 3, otherwise the tuner may exceed the oscillator radiation limits.

MEASURING METHOD OF POWER GAIN

The i. f. output of the tuner should be terminated with the circuit given below.
The terminals 7, 9 and 11 should be not connected.

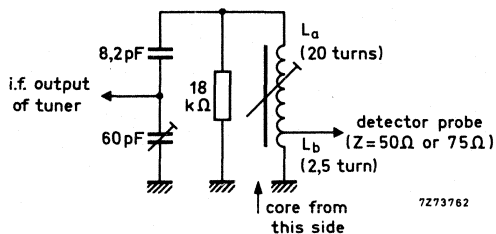

Fig. 15

Switch the tuner to the v. h. f. band; the tuning voltage should be 15 to 20 V.
Feed an i. f. sweep signal (500 to 1000 mV) to the i. f. injection point.
Adjust the trimmer (Fig. 15), tunable coil (L_a/L_b), i. f. output coil of the tuner L519 (Fig. 1) and the coupling between L_a and L_b to get the resonant curve as given below.

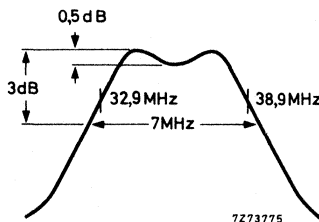

Fig. 16

Then display the r. f. + i. f. curve of the tuner at 190 MHz (picture carrier frequency) and make small corrections in the alignment of the i. f. coils (L_a/L_b and L519), if necessary, to get the markers 38,9 MHz and 32,9 MHz symmetrically on the slopes of the curve, and the peaks at equal amplitude.

Because the output impedance of the dummy circuit is 50 to 75 Ω , the power gain can be measured in the conventional manner by inserting tuner and dummy circuit between a 75 Ω source and a 75 Ω detector (or between a 50 Ω source and matching pad 50/75 Ω and a 50 Ω detector).

ACCESSORIES

aerial input transformer ELC1094, v. h. f. , catalogue number : 2422 542 10941;
aerial input transformer ELC2092, u. h. f. , catalogue number : 2422 542 12921;
coaxial aerial input assembly, catalogue number 3122 127 10450.

V.H.F. TELEVISION TUNER

with diode tuning

QUICK REFERENCE DATA

Systems	C. C. I. R. systems M and N (R. T. M. A.)
Channels	A2 to A6 (low v. h. f. band) A7 to A13 (high v. h. f. band)
Intermediate frequencies	
picture	45, 75 MHz
sound	41, 25 MHz

APPLICATION

Designed to cover the v. h. f. channels of C. C. I. R. systems M and N (R. T. M. A.). Thanks to its good signal-handling properties, the tuner is especially suited for strong signal areas.



DESCRIPTION

The ELC3082 is a v. h. f. tuner with electronic tuning and band switching, covering the low v. h. f. band (frequency range 54 to 88 MHz) and the high v. h. f. band (frequency range 174 to 216 MHz).

Mechanically, the tuner is built on a low-loss printed-wiring board, carrying all components, in a metal housing made of a rectangular frame and front and rear cover (see Fig. 2). The aerial connection is on one of the frame sides, all other connections (supply voltages, a. g. c. voltage, tuning and switching voltages) are made via feed-through capacitors in the under side. The mounting method is shown in Figs. 3 and 4.

Electrically, the tuner consists of v. h. f. and i. f. parts. The aerial signal is fed to the input filters, providing i. f. rejection and band selection. The filters are followed by a P-I-N diode attenuator, equipped with two diodes BA379. The output of the attenuator is connected to the emitter of the input transistor BF480, operating as r. f. amplifier in grounded base configuration. The same transistor also delivers the current drive for the P-I-N diode attenuator, controlled by an a. g. c. voltage fed to the transistor base. The combination of the diode attenuator with this high current transistor (I_E at normal gain about 10 mA) has excellent signal-handling properties within the whole a. g. c. range.

The collector load of the input transistor is formed by a double tuned circuit, transferring the signal to the emitter of the mixer transistor BF324.

Good signal-handling properties of this stage are achieved by high oscillator injection. The oscillator is equipped with a transistor BF324. In the low v. h. f. position, self-detection of the oscillator signal is used to back-bias the five switching diodes BA243/244 (or BA182), required for band switching between low and high v. h. f. channels.

Three capacitance diodes BB106 provide tuning of the r. f. circuits.

The collector of the mixer transistor is connected to a single tuned i. f. resonant circuit (about 20 MHz bandwidth), the output of which is fed to the i. f. output stage, equipped with another transistor BF324 in grounded base configuration.

This stage has also been designed especially for good signal-handling properties. The collector load of the i. f. output transistor is formed by a single tuned i. f. circuit, at the low end of which the i. f. signal is capacitively coupled out of the tuner.

The tuner can be used in combination with a u. h. f. tuner. In this case the u. h. f. i. f. signal is fed to the emitter of the i. f. output transistor, which acts as i. f. amplifier for u. h. f. as well as for v. h. f.

The u. h. f. i. f. input terminal can be used as an i. f. injection point for aligning the i. f. output circuit together with the i. f. amplifier of the television receiver. For the same purpose a separate i. f. injection point has been provided at the collector of the mixer.

The tuner requires transistor supply voltages of +12 V, a switching voltage of +12 V, a. g. c. voltages, variable from +5 V (normal operating point) to about +2,5 V (maximum a. g. c.) and a tuning voltage, variable from +0,5 V to +28 V.

The aerial input of the tuner is asymmetrical. For use in symmetrical aerial systems, aerial transformers (baluns) are available (see ACCESSORY).

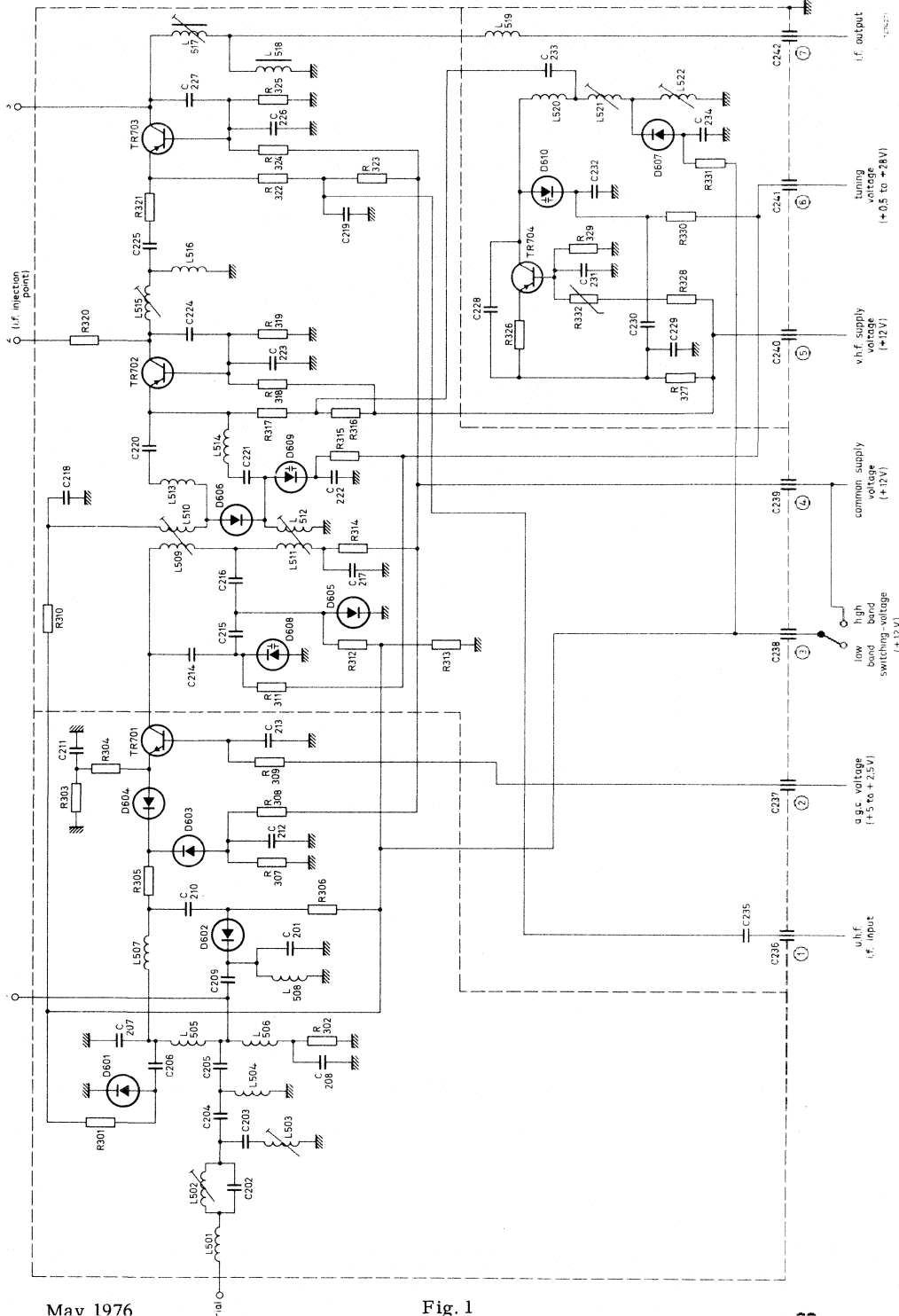

MECHANICAL DATA

Dimensions in mm

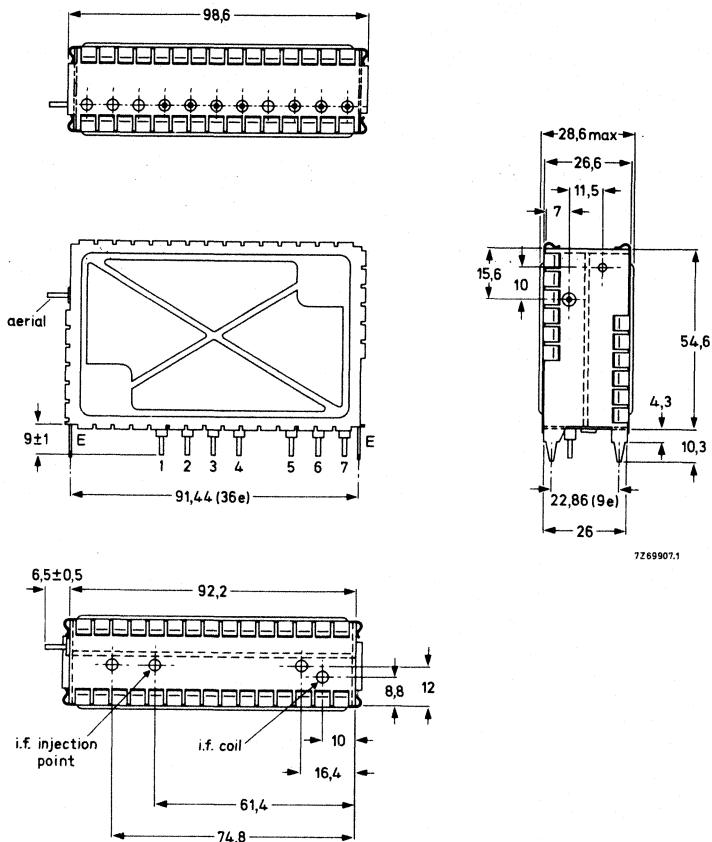

Fig. 2

- Terminal 1 = u.h.f. i.f. input
- 2 = a.g.c. voltage, +5 to +2,5 V
- 3 = switching voltage, +12 V
- 4 = common supply voltage, +12 V
- 5 = v.h.f. supply voltage, +12 V
- 6 = tuning voltage, +0,5 to +28 V
- 7 = i.f. output
- E = earth

Mounting

The tuner may be mounted by soldering it on to a printed-wiring board, using the piercing diagram shown in Fig. 3. (The tuner may also be mounted by means of a bracket. Information will be supplied upon request.)

The tuner may be mounted anywhere in the receiver and there are no restrictions on orientation.

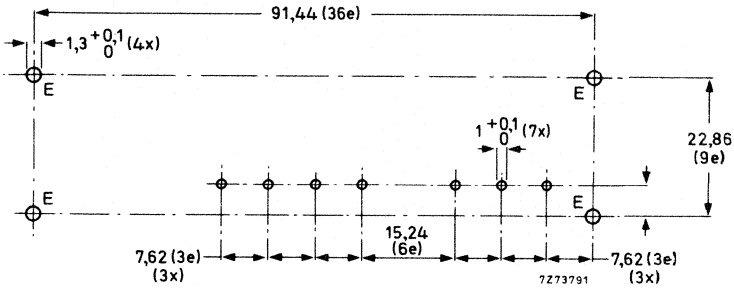

Fig. 3. Piercing diagram viewed from solder side of board; $e = 2,54$ mm (0,1 in).

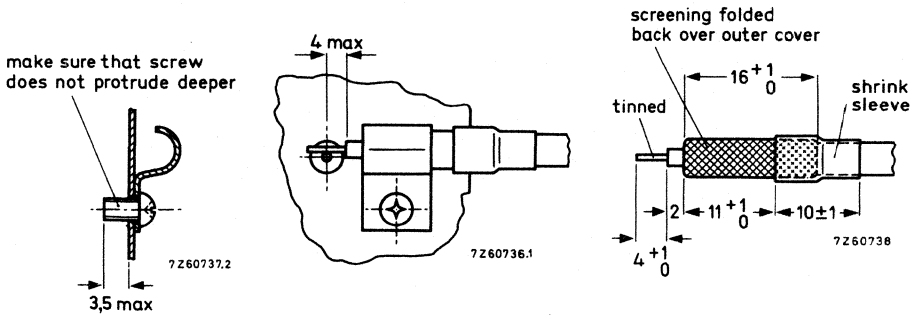

Fig. 4. Recommended fixing method of the aerial cable. Use a self-tapping screw.

ELECTRICAL DATA

Unless otherwise specified all electrical values apply at an ambient temperature of 25 ± 5 °C and a supply voltage of $12 \pm 0,3$ V.

Semiconductors

P-I-N attenuator	2 x BA379
r.f. amplifier	BF480
mixer	BF324
oscillator	BF324
tuning diodes	3 x BB106
switching diodes	5 x BA243/244 (or BA182)
i.f. amplifier	BF324

Ambient temperature range

operating	+5 to +55 °C
storage	-25 to +85 °C

Supply voltage

Current drawn from +12 V supply at nominal gain	+12 V \pm 10%
low band	46,5 mA \pm 10%
high band	63,5 mA \pm 10%

Notes - At 40 dB gain reduction the currents decrease about 5 mA.

- The supply voltage at terminal 4 should be carefully filtered to avoid hum modulation in one of the P-I-N diodes when the attenuator is biased to higher attenuation ratios. Under most unfavourable conditions a ripple voltage of 3 mV (p-p) may produce a disturbance which is just visible.

A.G.C. voltage (Figs. 5 and 6)

low band, at nominal gain	+5 \pm 0,2 V ¹⁾
at 40 dB gain reduction	+3,3 V (typical)
high band, at nominal gain	+5 \pm 0,2 V ¹⁾
at 40 dB gain reduction	+3,3 V (typical)

A.G.C. current

at nominal gain	max. 1 mA
with a.g.c.	max. 1 mA

Tuning voltage range (Figs. 7 and 8)

Current drawn from 28 V tuning voltage supply	max. 0,5 mA
---	-------------

Note - The source impedance of the tuning voltage, offered to terminal 6, must be max. 100 k Ω at tuning voltages below 5 V.

Switching voltage

low band	open circuit
high band	+12 V \pm 10%

Note - In the low band position the tuner produces a negative voltage (3 to 8 V) at terminal 3; this terminal must not be loaded with an external resistance below 50 M Ω .

¹⁾ This value may be increased to 5,5 V if a certain deterioration of signal handling is accepted. At voltages above 5,5 V the cross-modulation in band may deteriorate rapidly.

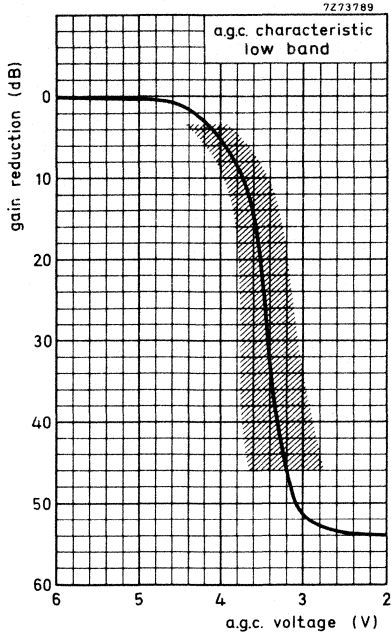

Fig.5

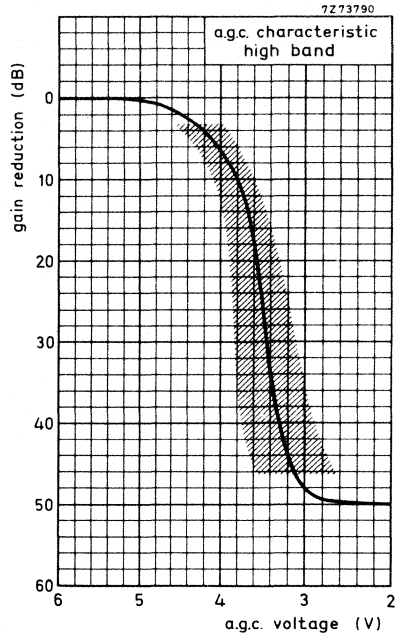

Fig.6

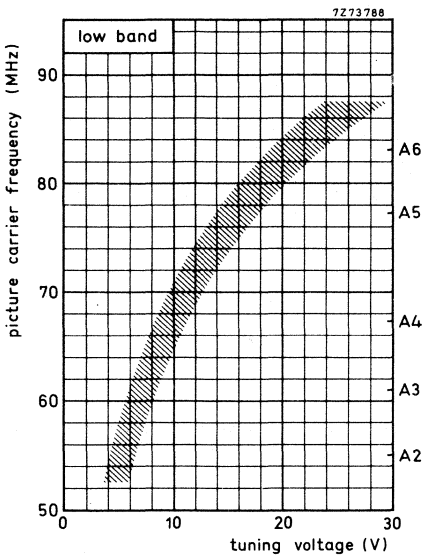

Fig.7

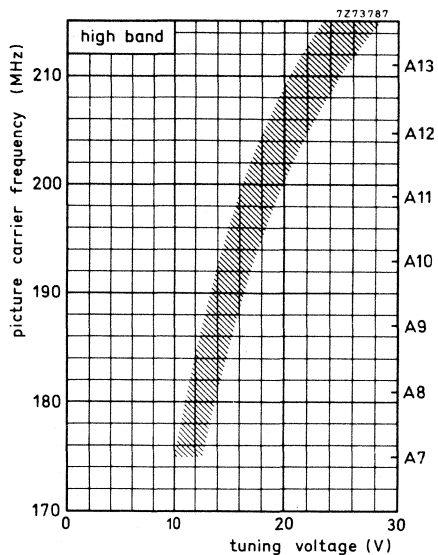

Fig.8



Frequency ranges		
low band	channel A2 (picture carrier 55, 25 MHz) to channel A6 (picture carrier 83, 25 MHz). Margin at the extreme channels : min. 2 MHz.	
high band	channel A7 (picture carrier 175, 25 MHz) to channel A13 (picture carrier 211, 25 MHz). Margin at the extreme channels : min. 3 MHz.	
Intermediate frequencies		
picture	45, 75 MHz	
sound	41, 25 MHz	
Input impedance		
asymmetrical	75 Ω	
symmetrical	300 Ω (see ACCESSORY).	
V. S. W. R. (between picture carrier and sound carrier)	v. s. w. r. at nom. gain	max. v. s. w. r. during gain control
low band	max. 3, 5	max. 3, 5
high band	max. 4	max. 4
A. G. C. range		
low band	min. 40 dB (typ. 54 dB)	
high band	min. 40 dB (typ. 50 dB)	
R. F. curves		
bandwidth, low band	typ. 7 to 10 MHz	
high band	typ. 8 to 10 MHz	
tilt, low band	max. 3 dB	
high band	max. 3 dB	
Power gain (see also MEASURING METHOD OF POWER GAIN)		
low band	min. 24 dB	
channel A2	typ. 27 dB	
channel A6	typ. 29 dB	
high band	min. 25 dB	
channel A7	typ. 28 dB	
channel A13	typ. 31 dB	
Noise figure		
low band	max. 9, 5 dB (typ. 7 dB)	
high band	max. 9, 5 dB (typ. 7, 5 dB)	
I. F. rejection		
low band, channel A2	min. 54 dB	
channel A3	min. 57 dB	
channels A4 to A6	min. 60 dB	
high band	min. 60 dB	



Image rejection

low band	min. 56 dB
high band	min. 50 dB

Signal handling

Minimum input signal (e. m. f.) producing cross-modulation (1%)

in channel

wanted signal: picture carrier frequency,
interfering channel: sound carrier

frequency

in band

wanted signal: picture carrier frequency
of channel N,

interfering signal: picture carrier of
channel $N \pm 2$

interfering signal: picture carrier of
channel $\geq N \pm 3$

max. gain	with a. g. c.
typ. 20 mV	typ. > 500 mV
typ. 100 mV	typ. > 500 mV
typ. 250 mV	typ. > 500 mV

1)

Minimum input signal (e. m. f.) producing overloading, at nominal gain
at maximum a. g. c.

typ. 50 mV	} 2)
typ. > 500 mV	

Minimum input signal (e. m. f.) at nominal gain producing a shift of the oscillator frequency of 10 kHz, low band
high band

typ. 50 mV	} 3)
typ. 30 mV	

Detuning of the i. f. output circuit as a result of band switching and tuning

max. 150 kHz

Shift of oscillator frequency

at a change of the supply voltage of 5%

low band

high band

max. 300 kHz
max. 300 kHz

during warm-up time (measured between 5 s and 15 min after switching on)

low band

high band

max. 150 kHz
max. 150 kHz

1) This e. m. f. (open voltage) is referred to an impedance of 75Ω.

1% cross-modulation means that 1% of the modulation depth of the interfering signal is transferred to the wanted signal.

2) This e. m. f. (open voltage) is referred to an impedance of 75Ω.

Criterion of overloading: 30% compression of the synchronization pulses of a standard television signal or a noticeable deterioration of the picture quality.

3) This e. m. f. (open voltage) is referred to an impedance of 75Ω.



ELC3082

V.H.F. TELEVISION TUNER
with diode tuning

3122 127 19681

Drift of oscillator frequency
at a change of the ambient temperature
from 25 to 50 °C

low band	max. 500 kHz
high band	max. 500 kHz

Oscillator radiation

The tuner is in conformity with the radiation requirements of C.I.S.P.R. Recommendation No. 24/2 and the corresponding F.C.C. rules, provided the tuner is installed in a professional manner.

Microphonics

If the tuner is installed in a professional manner, there will be no microphonics.



ALIGNMENT OF THE I.F. CIRCUIT

For i.f. injection the u.h.f. i.f. input (terminal 1) or the i.f. injection point at the collector of the mixer transistor (at the top of the tuner, Fig. 2) can be used. The aligning can be done with any channel tuned. A probe as shown in Fig. 9 should be used.

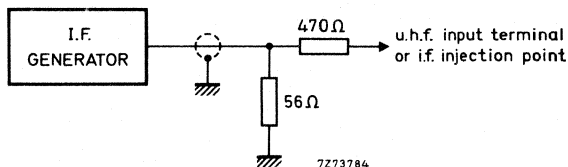

Fig. 9

The signal attenuation between the i.f. generator and the i.f. output of the tuner is about 4 dB when injection is done via the injection point, and about 8,5 dB in the case of injection via the u.h.f. i.f. input.

The i.f. output circuit is detuned about +300 kHz¹⁾ or -150 kHz¹⁾ when injection is done via the injection point or via the u.h.f. i.f. input respectively.

MEASURING METHOD OF POWER GAIN

The i.f. output of the tuner should be terminated with the RC-circuit given in Fig. 10.

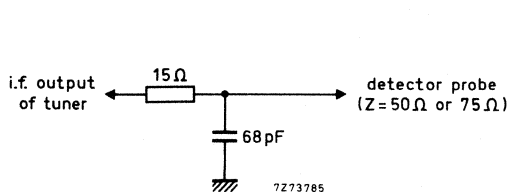

Fig. 10

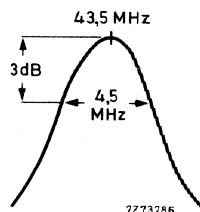

Fig. 11

The RC-circuit roughly matches the i.f. output impedance to 75 Ω at the resonant frequency of the i.f. output circuit, which should be tuned to 43,5 MHz. The bandwidth should be approx. 4,5 MHz.

Because the input and output impedances of the tuner are now 75 Ω, the power gain can be measured in the conventional manner by inserting tuner and RC-circuit between a 75 Ω source and a 75 Ω detector (or between a 50 Ω source and matching pad 50/75 Ω and a 50 Ω detector).

ACCESSORY

Aerial input transformer ELC1094, v. h. f. , catalogue number : 2422 542 10941.

¹⁾ Reference: normal operation with r.f. signal via aerial input.

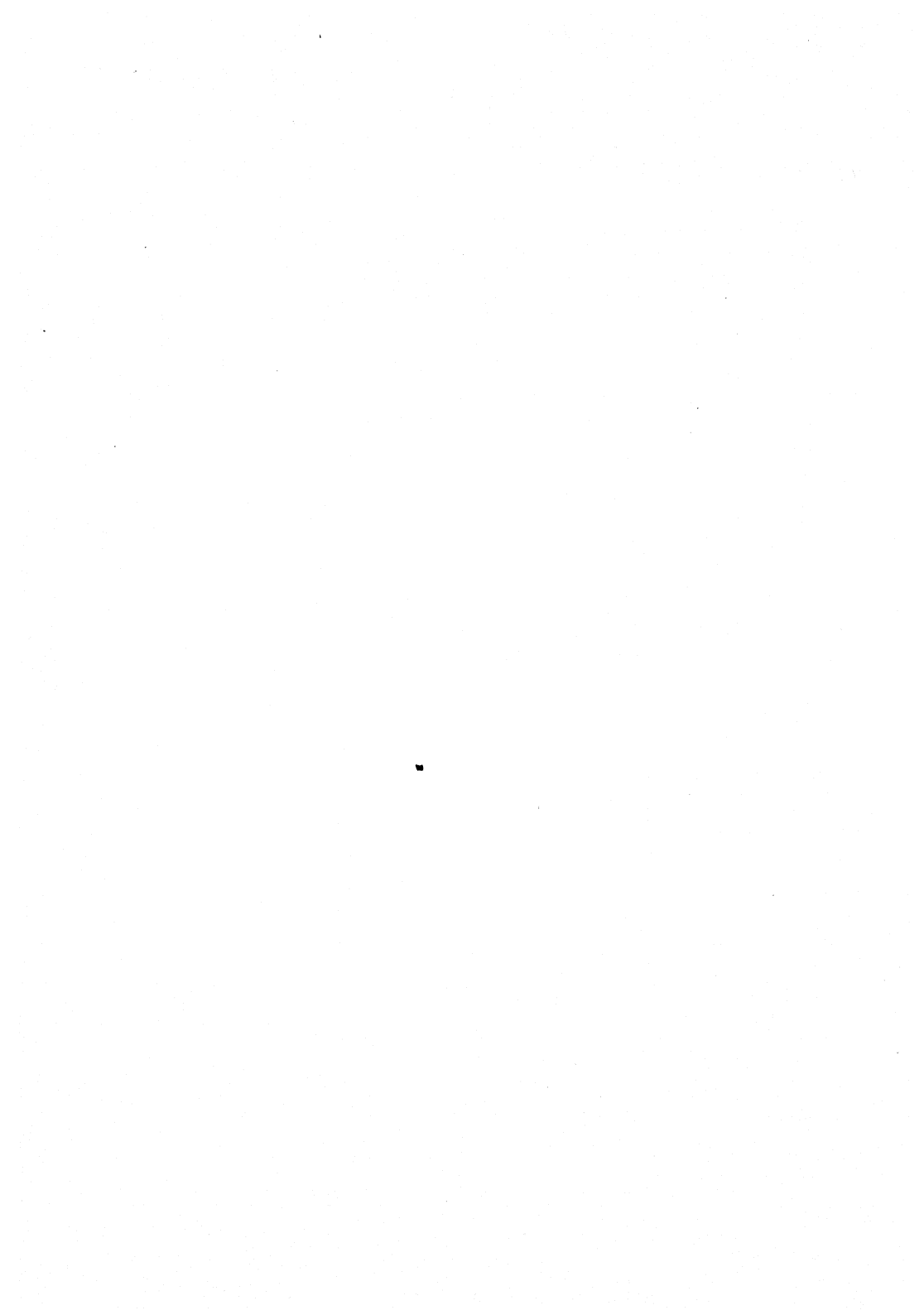

U.H.F. TELEVISION TUNERS

QUICK REFERENCE DATA

Systems	C.C.I.R. systems I (United Kingdom), G, H and K	
Channels	E21 to E69	
Intermediate frequencies	<u>systems I and K</u>	<u>systems G and H</u>
	picture	38,9 MHz
	sound	33,4 MHz

APPLICATION

These tuners are designed to be used in u.h.f. single standard receivers. In combination with v.h.f. tuner V311, V314 or V315 they can also be used in v.h.f./u.h.f. receivers.

The tuners meet the special requirements of the United Kingdom.

The U321LO is a special version of the U321: an output voltage from the local oscillator is made available for driving digital tuning systems. Apart from this the tuners are identical.



DESCRIPTION

The tuners are u.h.f. tuners with electronic tuning, covering the u.h.f. band from 470 to 860 MHz.

Mechanically, the tuner is built on a printed-wiring board, carrying all components, in a metal housing made of a rectangular frame and front and rear cover (see Fig. 2). The shielded aerial connection is on one of the frame sides, all other connections (supply voltages, a.g.c., tuning voltage, i.f. injection, i.f. output) are made via terminals on the bottom. The mounting method is shown in Figs 3 and 4.

Tuner U321LO has a coaxial socket on the top of the frame for coupling out the oscillator sample.

Electrically, the tuner consists of an input circuit with a high-pass characteristic, followed by a p-i-n diode attenuator (2 diodes BA379) and the input transistor BF480 in grounded-base configuration. This transistor operates at an emitter current of about 5 to 8 mA, featuring good noise figures and good signal handling properties. The a.g.c. current for driving the p-i-n diode attenuator is directly controlled by the a.g.c. system of the receiver.

The collector load of the input transistor is formed by a double tuned circuit, transferring the signal to the mixer diode BA280. The selectivity of this circuit at the image frequency has been improved. The mixer diode BA280 is driven by an oscillator, equipped with a transistor BF480. At the U321LO the oscillator sample is coupled out of the mixer via a small capacitor in series with a resistor.

The i.f. signal, originated in the mixer, is amplified by a transistor BF324 in grounded-base configuration. The combination of the Schottky-barrier diode BA280 and the i.f. transistor BF324 also features good noise figures and good signal handling properties. Three capacitance diodes BB205B tune the double tuned circuit and the oscillator.

The i.f. output circuit of the tuner is a single tuned one, at the low end of which the i.f. signal is coupled out of the tuner. A d.c. path to earth for the collector current of the i.f. transistor BF324 has to be provided outside the tuner, preferably by a choke of about $5 \mu\text{H}$. Damping of the i.f. output circuit and matching of the i.f. output to the i.f. circuit of the receiver can be achieved by connecting a series resistor and a parallel capacitor outside the tuner.

An i.f. injection point has been provided at the collector of the i.f. transistor, connected to terminal 7.



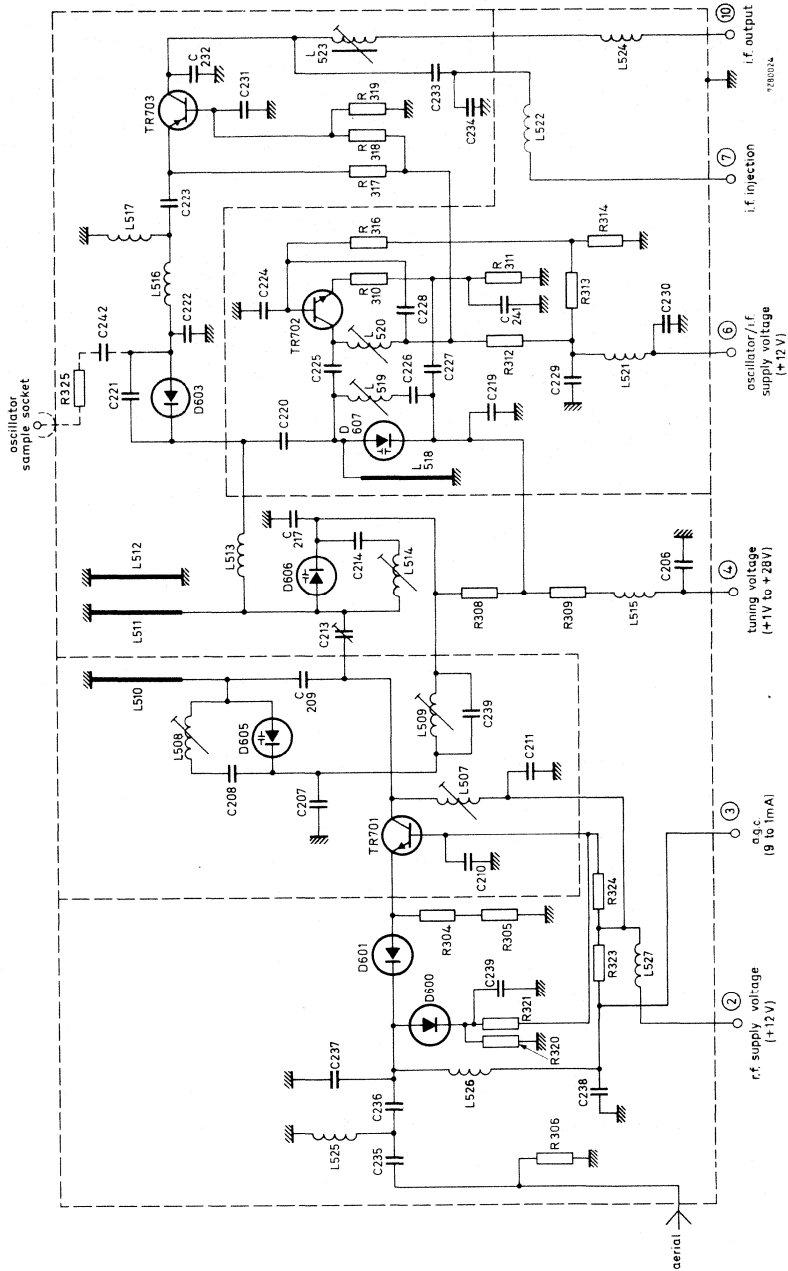

Fig. 1.



MECHANICAL DATA

Dimensions in mm

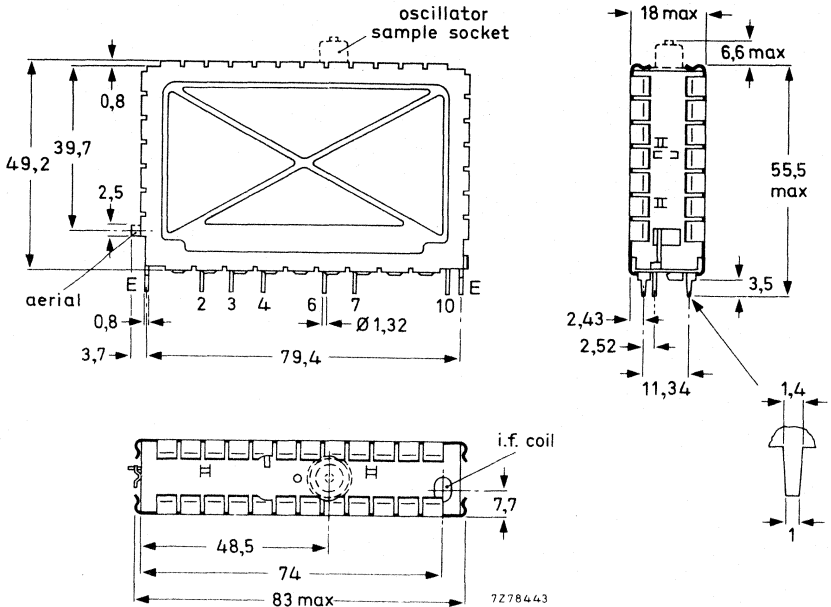

Fig. 2a The oscillator sample socket, drawn with dotted lines, applies only to tuner U321LO.

Terminal

- 2 = r.f. supply voltage, +12 V
- 3 = a.g.c. current, -9 to -1 mA
- 4 = tuning voltage, +1 to +28 V
- 6 = oscillator/i.f. supply voltage, +12 V
- 7 = i.f. injection point
- 10 = i.f. output

Note: When the tuner is operated together with a v.h.f. tuner, only the supply voltage at terminal 6 should be switched off during v.h.f. operation.

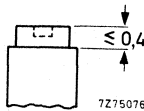

Fig. 2b I.F. output coil.
Torque for alignment: 2 to 15 mNm
Press-through force: ≥ 10 N

Mass approx. 75 g

Mounting

The tuner may be mounted by soldering it on to a printed-wiring board, using the piercing diagram shown in Fig. 3. (The tuner may also be mounted by means of a socket. Information will be supplied upon request.)

It is recommended that the tuner be installed in the cool part of the receiver cabinet and not exposed to the vibrations of the loudspeaker. There are no restrictions on orientation.

The solderability of the terminals and mounting tabs is according to IEC 68-2, test Ta ($230 \pm 10 \text{ }^\circ\text{C}$, $2 \pm 0,5 \text{ s}$). The resistance to soldering heat is according to IEC 68-2, test Tb ($260 \pm 5 \text{ }^\circ\text{C}$, $10 \pm 1 \text{ s}$).

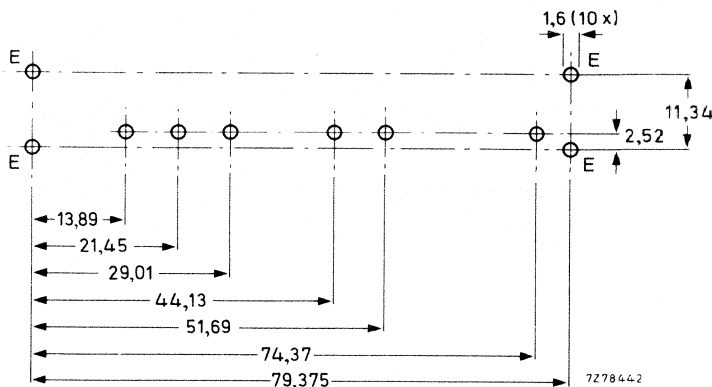

Fig. 3 Piercing diagram viewed from solder side of board.

For connection to the socket on the top of tuner U322LO a coaxial plug has to be used; type 3/2-50 (manufacturer: Daut und Rietz) is recommended.

The aerial cable should be connected as follows:

- strip the cable according to Fig. 4B;
- fix the cable as indicated in Fig. 4C and solder the inner conductor on the aerial tag;
- insert lugs on immunity shield under the tabs on tuner body, push the shield into position so that the locating tags snap into place in the tuner body.

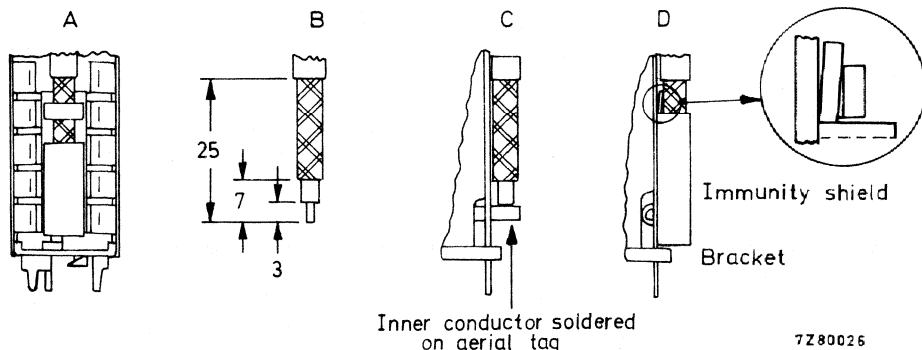

Fig. 4 Fixing of the aerial cable.

Recommended cable: DAVU wire CX4004 (outer sheath diameter 5,32 mm).

ELECTRICAL DATA

The electrical values are measured on the u.h.f. tuner alone, but they are also valid for the u.h.f. tuner in combination with a v.h.f. tuner V311, V314 or V315. Unless otherwise specified all electrical values apply at an ambient temperature of 25 ± 5 °C, a relative humidity of $60 \pm 15\%$, a supply voltage of $12 \pm 0,3$ V and an a.g.c. current of $-9 \pm 0,2$ mA.

Within the given tolerance range of supply voltage and a.g.c. current only insignificant deviations from the specified values can be expected. Under the extreme conditions of temperature and humidity as given below, the tuner will function normally, but some specified limits may be exceeded.

General

Semiconductors

p-i-n diode	2 x BA379
r.f. amplifier	BF480
mixer	BA280
oscillator	BF480
tuning diodes	3 x BB205B
i.f. amplifier	BF324

Ambient temperature range

operating	+5 to +55 °C
storage	-25 to +85 °C

Relative humidity

max. 90%

Voltages and currents

Supply voltage	+12 V \pm 10%
----------------	-----------------

Note: The supply voltage at terminal 2 (input stage) should be filtered to avoid hum modulation in one of the p-i-n diodes when the attenuator is biased to higher attenuation ratios.

Current drawn from +12 V supply

r.f. amplifier, at nominal gain	typ. 16 mA
r.f. amplifier, at 26 dB gain reduction	typ. 13 mA
oscillator/i.f. amplifier	max. 16 mA

A.G.C. current (Fig. 5)

at nominal gain	$-9 \pm 0,5$ mA
at 26 dB gain reduction	typ. $-5,6$ mA

Tuning voltage range (Fig. 6)

+1 to +28 V

Current drawn from +28 V tuning voltage supply

max. 0,5 μ A

Slope of tuning characteristic

min. 5 MHz/V

Note: The source impedance of the tuning voltage offered to terminal 4 must be maximum 47 k Ω at tuning voltages below 3 V.



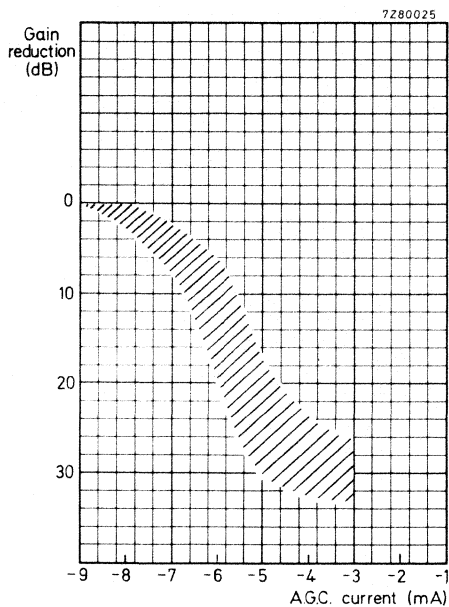

Fig. 5.

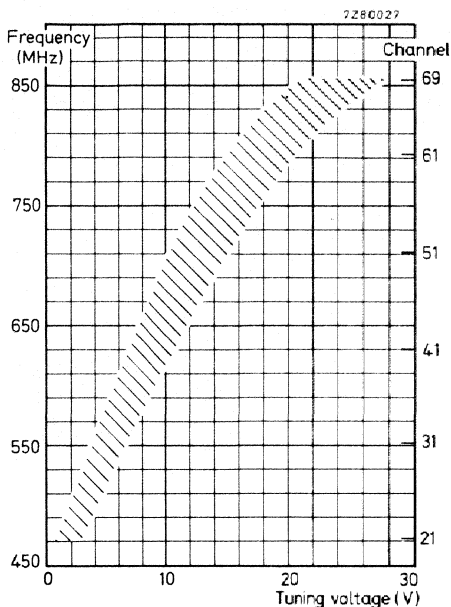

Fig. 6.

Oscillator sample voltage; only valid for U321LO

at +12 V supply voltage and

$T_{amb} = +25^{\circ}C$

within the given tolerance range of supply voltage and given operating temperature range, and within the tuning voltage range +0,5 to +28 V

typ. 33 mV

min. 13 mV

max. 100 mV

Note: A tuning voltage higher than +28 V will not be harmful for the tuner and may be applied at the user's own risk. Under this condition the published reverse voltage limit of the oscillator tuning diode will be exceeded; the oscillator frequency will never decrease with increasing tuning voltage.

Frequencies

Frequency range

channel E21 (picture carrier 471,25 MHz)
to channel E69 (picture carrier 855, 25 MHz).
Margin at the extreme channels: min. 3 MHz.

Intermediate frequencies

picture
sound

systems I, K	systems G, H
39,5 MHz	38,9 MHz
33,5 MHz	33,4 MHz

The oscillator frequency is higher than the aerial signal frequency.

Note: The tuner is aligned in such a way that the i.f. frequencies of the four systems can be applied.

Wanted signal characteristics

Input impedance
asymmetrical

75 Ω

Input impedance of oscillator sample socket; **only valid for U321LO**
asymmetrical

75 Ω

V.S.W.R. and reflection coefficient
at picture carrier frequency, at
nominal gain

v.s.w.r.

max. 5

reflection coefficient

max. 66%

V.S.W.R. and reflection coefficient at oscillator sample socket; **only valid for U321LO**

v.s.w.r. at $f_{osc} < 600$ MHz

max. 4 (typ. 3)

v.s.w.r. at $f_{osc} > 600$ MHz

max. 3 (typ. 2)

reflection coefficient at $f_{osc} < 600$ MHz

max. 60% (typ. 50%)

reflection coefficient at $f_{osc} > 600$ MHz

max. 50% (typ. 33%)

R.F. curves, bandwidth

typ. 18 MHz

R.F. curves, tilt (only for i.f. 39,5/33,5 MHz)

on any channel the amplitude difference between the top of the r.f. resonant curve and the picture carrier marker, the sound carrier marker, or any frequency between them will not exceed 3 dB at nominal gain, and 4 dB in the a.g.c. range between nominal gain and 20 dB gain reduction.

A.G.C. range (Fig. 5)

min. 26 dB (typ. 31 dB)

Power gain (see also Measuring method of power gain)

min. 18 dB

channel E21

typ. 23 dB

channel E40

typ. 22 dB

channel E69

typ. 24 dB

Gain difference between any two channels

typ. 3 dB

Noise figure

max. 10 dB

channel E21

typ. 6,5 dB

channel E40

typ. 7,5 dB

channel E69

typ. 8 dB

Overloading

Input signal producing 1 dB gain
compression at nominal gain

typ. 88 dB (μV) into 75 Ω

Input signal producing either a
detuning of the oscillator of +300 kHz
or -1000 kHz or stopping of the
oscillations at nominal gain

typ. 100 dB (μV) into 75 Ω



Unwanted signal characteristics

Image rejection (measured at picture carrier frequency)

channels E21 to E60 min. 53 dB

I.F. rejection (measured at picture carrier and colour sub-carrier frequency)

min. 60 dB

Harmonic content of oscillator sample; **only valid for U321LO**

Suppression of harmonics which fall into the frequency range below 1000 MHz (second harmonics of fundamentals below 500 MHz)

min. 15 dB (typ. 20 dB) below oscillator fundamental

R.F. rejection at oscillator sample socket; **only valid for U321LO**

Signal voltage at oscillator sample socket (input signals of wanted frequency 70 dB (μV) into 75 Ω ; tuner operating at nominal gain)

min. 17 dB (typ. 24 to 34 dB) below oscillator fundamental

I.F. rejection at oscillator sample socket; **only valid for U321LO**

I.F. signals at oscillator sample socket (converted from input signals of wanted frequency 70 dB (μV) into 75 Ω ; tuner operating at nominal gain)

min. 20 dB (typ. 35 dB) below oscillator fundamental

$N \pm 4$ rejection

Interference signal for an interference ratio of 53 dB referred to wanted picture carrier (picture to sound carrier ratio of 7 dB; wanted signal 60 dB (μV); tuner operating at nominal gain)

typ. 80 dB (μV) into 75 Ω

Cross modulation

Input signal producing 1% cross modulation, i.e. 1% of the modulation depth of the interfering signal is transferred to the wanted signal.

In channel cross modulation (wanted signal: picture carrier frequency; interfering signal: sound carrier frequency)

at nominal gain (wanted input level 60 dB (μV))

typ. 84 dB (μV) into 75 Ω

at 26 dB gain reduction

(wanted input level 86 dB (μV))

typ. 100 dB (μV) into 75 Ω

In band cross modulation (wanted signal: picture carrier channel N; interfering signal: picture carrier of channel $N \pm 5$)

at nominal gain (wanted input level 60 dB (μV))

typ. 90 dB (μV) into 75 Ω

at 26 dB gain reduction

(wanted input level 86 dB (μV))

typ. 100 dB (μV) into 75 Ω

Out of band cross modulation, at nominal gain

v.h.f. I

min. 108 dB (μV) into 75 Ω

v.h.f. III

min. 94 dB (μV) into 75 Ω



Oscillator characteristics

Pulling

Input signal of tuned frequency producing a shift of the oscillator frequency of 10 kHz, at nominal gain

typ. 84 dB (μ V) into 75 Ω

Shift of oscillator frequency

at a change of the supply voltage of 5%

max. 500 kHz

Drift of oscillator frequency

during warm-up time (after the tuner has been completely out of operation for 15 min, measured between 5 s and 15 min after switching on)

max. 250 kHz

during warm-up time (after the input stage is in operation for 15 min, measured between 2 s and 15 min after switching on the oscillator/i.f. stage)

max. 250 kHz

at a change of the ambient temperature from +25 to +50 $^{\circ}$ C (measured after 3 cycles from +25 to +55 $^{\circ}$ C)

max. 1000 kHz

I.F. circuit characteristics

Bandwidth of i.f. output circuit

5 MHz \pm 500 kHz

Note: I.F. output of the tuner terminated with the circuit shown in Fig. 7; tuning voltage 15 V.

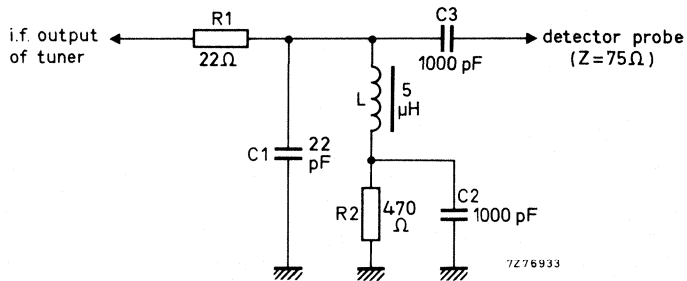

Fig. 7.

Bandwidth variation of i.f. output circuit as a result of r.f. tuning

max. 350 kHz

Note: I.F. output of the tuner terminated with a modified circuit of Fig. 7, i.e. a 100 pF capacitor is connected in parallel with C1 and R1 is short-circuited; tuning voltage 15 V.

Detuning of the i.f. output circuit
as a result of r.f. tuning max. 350 kHz

Note: I.F. output of the tuner terminated with a modified circuit of Fig. 7, i.e. a 100 pF capacitor is connected in parallel with C1 and R1 is short-circuited; tuning voltage 15 V.

Minimum tuning range of i.f. output coil 33 to 40 MHz

Note: I.F. output of the tuner terminated with the circuit shown in Fig. 6; tuning voltage 15 V.

Attenuation between i.f. injection point
and i.f. output of the tuner typ. 23 dB

Miscellaneous

Radio interference

Oscillator radiation and oscillator
voltage at the aerial terminal

Within the limits of C.I.S.P.R. 13 (1975)
and VDE 0872/7.72.*
For the oscillator radiation use is made
of the relaxed limit of 3 mV/m
(70 dB μ V/m).

Microphonics

There will be no microphonics, provided
the tuner is installed in a professional
manner.

Surge protection

Protection against voltages max. 8 kV

Note: Three discharges of a 470 pF capacitor into the aerial terminal.

Protection against flashes max. 30 kV, 400 mWs

Note: A flashover circuit producing flashes with frequencies of 1 to 20 Hz for 30 s is connected to the aerial terminal.

* For U321LO: when the oscillator sample socket is either open or terminated with a shielded resistor of 75 Ω .



ADDITIONAL INFORMATION

I.F. injection

The tuner is provided with an i.f. injection point at the collector of the i.f. transistor (coupled via a capacitor to terminal 7). The i.f. generator can be connected directly to this point (Fig. 8). The tuner needs normal supply voltages and a tuning voltage of 15 V; the i.f. output should be loaded with the circuit shown in Fig. 7.

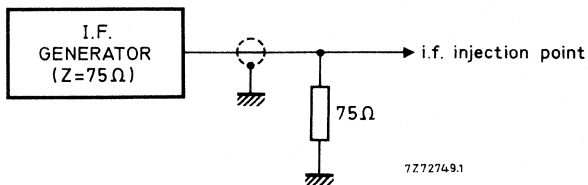

Fig. 8.

Connection of the i.f. amplifier

The tuner needs a d.c. path from the i.f. output terminal (10) to earth, preferably via a choke of approx. $5 \mu\text{H}$ outside the tuner (Fig. 9). Where the tuner is used in combination with a v.h.f. tuner, this choke can be common for both tuners; a resistor in series with the choke can make ineffective the i.f. output circuit of the switched-off tuner. For damping the i.f. output circuit and matching the i.f. output impedance of the tuner to the i.f. amplifier, a series resistor and a parallel capacitor as shown in Fig. 9 should be used.

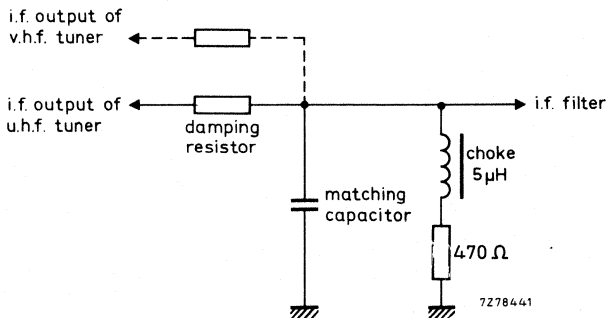

Fig. 9.

Measuring method of power gain

The i.f. output of the tuner should be terminated with the RC-circuit given in Fig. 7.

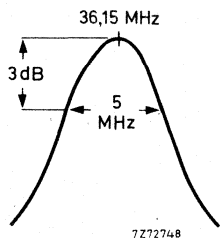

Fig. 10.

The RC-circuit roughly matches the i.f. output impedance to 75Ω at the resonant frequency of the i.f. output circuit, which should be tuned to 36,15 MHz; the bandwidth should be approx. 5 MHz (Fig. 10).

Because the input and output impedances of the tuner are now 75Ω , the power gain can be measured in the conventional manner by inserting tuner and RC-circuit between a 75Ω source and a 75Ω detector.

Alignment of the i.f. output coil

The i.f. output coil should be adjusted with a brass tool with a blade as shown in Fig. 11. A suitable tool is available under catalogue number 7122 005 47680.

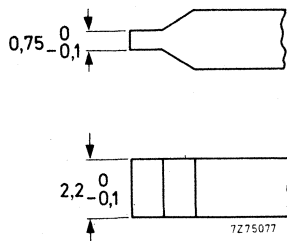

Fig. 11.

ACCESSORIES

Connector assembly for use of tuner U321 or U321LO in combination with v.h.f. tuner V311, V314 or V315: connector, catalogue number 3112 200 20720;
washer, catalogue number 3112 221 01220;
clamp, catalogue number 3112 274 13220.

U.H.F. TELEVISION TUNERS

QUICK REFERENCE DATA

Systems	C.C.I.R. systems G, H, I and K	
Channels	E21 to E69	
Intermediate frequencies	<u>systems G and H</u>	<u>systems I and K</u>
picture	38,9 MHz	39,5 MHz
sound	33,4 MHz	33,5 MHz

APPLICATION

These tuners are designed to cover the u.h.f. channels E21 to E69 of C.C.I.R. systems G, H, I and K.

In combination with a suitable v.h.f. tuner, e.g. V311, V314 or V315 they can be used in v.h.f./u.h.f. receivers. The aerial inputs and i.f. outputs of both tuners can then be connected in parallel **without** additional circuitry.

The U322LO is a special version of the U322: an output voltage from the local oscillator is made available for driving digital tuning systems. Apart from this the tuners are identical.



DESCRIPTION

The tuners are u.h.f. tuners with electronic tuning, covering the u.h.f. band from 470 to 860 MHz.

Mechanically, the tuners are built on a printed-wiring board, carrying all components, in a metal housing made of a rectangular frame and front and rear cover (see Fig. 2a). All connections (aerial, supply voltages, a.g.c. voltage, tuning voltage, i.f. injection, i.f. output) are made via terminals on the underside. The mounting method is shown in Fig. 3. Tuner U322LO has a coaxial socket on the top of the frame for coupling out the oscillator sample.

Electrically, the tuner consists of an input circuit with a high-pass characteristic, followed by a P-I-N diode attenuator (1 diode BA379) and the input transistor BF480 in grounded-base configuration. This transistor operates at an emitter current of about 8 to 10 mA, featuring good noise figures and good signal handling properties. It also supplies the current drive for the P-I-N diode attenuator, controlled by an a.g.c. voltage fed to the transistor's base. This combination has good signal handling properties throughout the a.g.c. range. The collector load of the input transistor is formed by a double tuned circuit, transferring the signal to the mixer diode BA280 (or MBD102). The selectivity of this circuit at the image frequency has been improved by special means. The mixer diode BA280 (or MBD102) is driven by an oscillator, equipped with a transistor BF480. At the U322LO the oscillator sample is coupled out of the mixer via a small capacitor in series with a resistor.

The i.f. signal, originated in the mixer, is amplified by a transistor BF324 in grounded-base configuration. The combination of the Schottky-barrier diode BA280 (or MBD102) and the i.f. transistor BF324 also features good noise figures and good signal handling properties. Three capacitance diodes BB105B tune the double tuned circuit and the oscillator.

The i.f. output circuit of the tuner is a single tuned one, at the low end of which the i.f. signal is coupled out of the tuner. A d.c. path to earth for the collector current of the i.f. transistor BF324 has to be provided outside the tuner, preferably by a choke of about 5 μ H. Damping of the i.f. output circuit and matching of the i.f. output to the i.f. circuit of the receiver can be achieved by connecting a series resistance and a parallel capacitance outside the tuner.

An i.f. injection point has been provided at the collector of the i.f. transistor, connected to terminal 7.

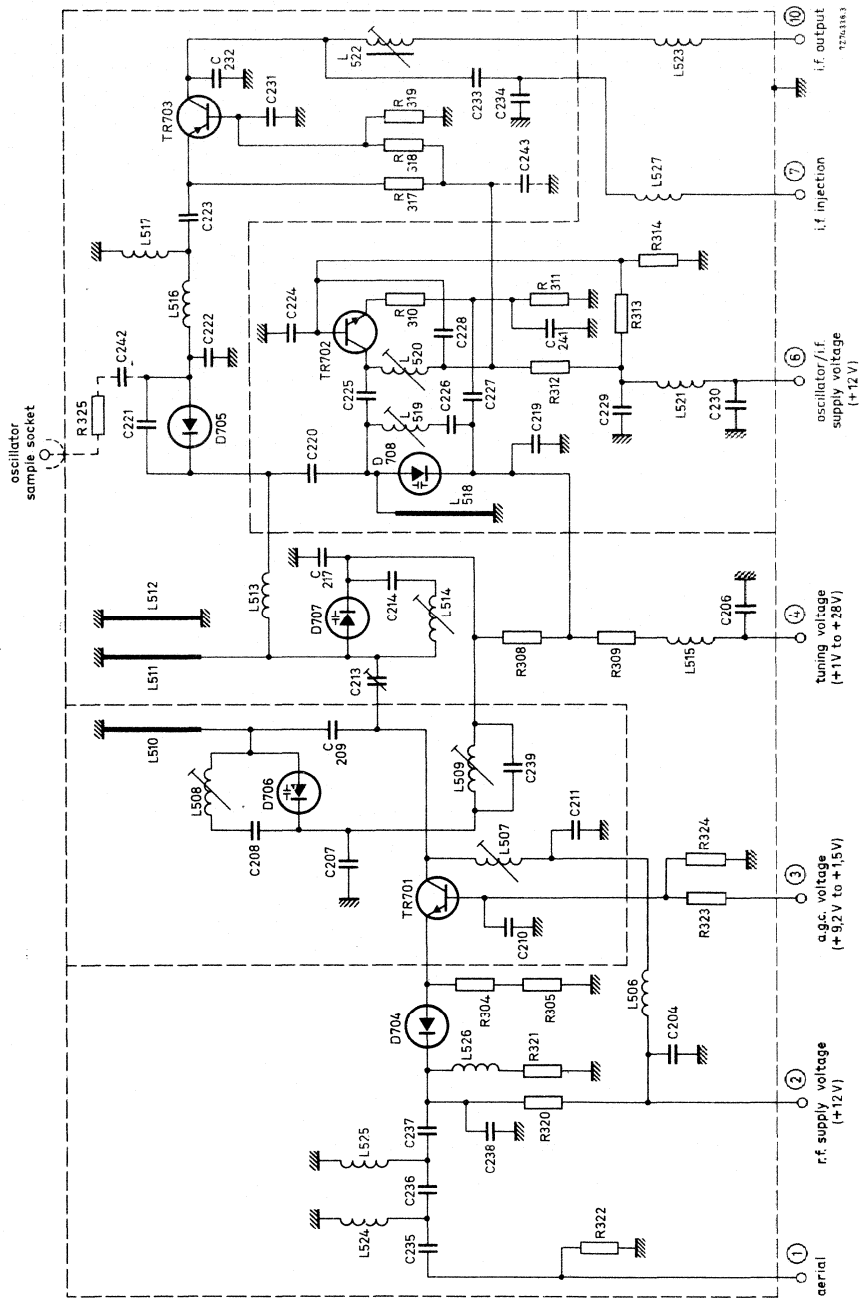

Fig. 1.



MECHANICAL DATA

Dimensions in mm

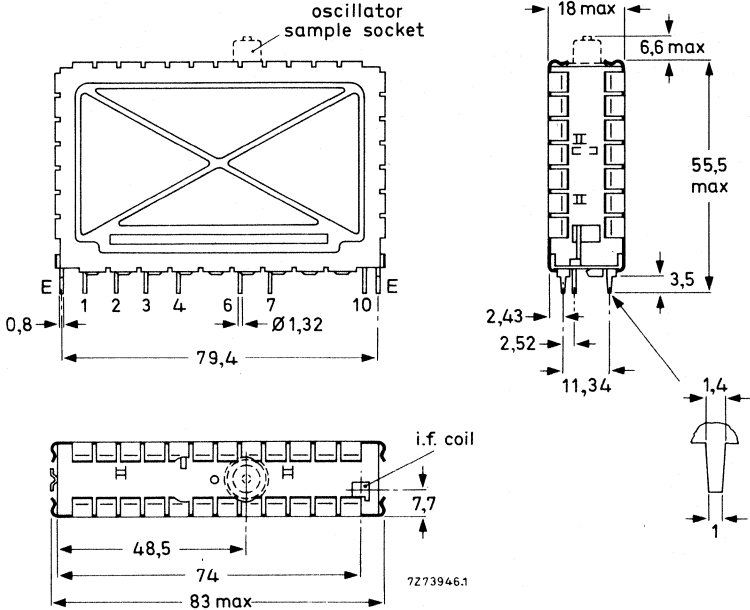

Fig. 2a The oscillator sample socket, drawn with dotted lines, applies only to tuner U322LO.

Terminal 1 = aerial

2 = r.f. supply voltage, + 12 V

3 = a.g.c. voltage, + 9,2 to + 1,5 V

4 = tuning voltage, + 1 to + 28 V

6 = oscillator/i.f. supply voltage, + 12 V

7 = i.f. injection point

10 = i.f. output

Note: When the tuner is operated together with a v.h.f. tuner, only the supply voltage at terminal 6 should be switched off during v.h.f. operation.

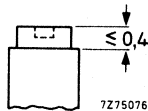

Fig. 2b I.F. output coil.

Torque for alignment : 2 to 15 mNm

Press-through force : ≥ 10 N

Mass

approx. 75 g

Mounting

The tuner may be mounted by soldering it on to a printed-wiring board, using the piercing diagram shown in Fig. 3. (The tuner may also be mounted by means of a socket. Information will be supplied upon request.)

It is recommended that the tuner be installed in the cool part of the receiver cabinet and not exposed to the vibrations of the loudspeaker. There are no restrictions on orientation.

The solderability of the terminals and mounting tabs is according to IEC 68-2, test Ta (230 ± 10 °C, $2 \pm 0,5$ s). The resistance to soldering heat is according to IEC 68-2, test Tb (260 ± 5 °C, 10 ± 1 s).

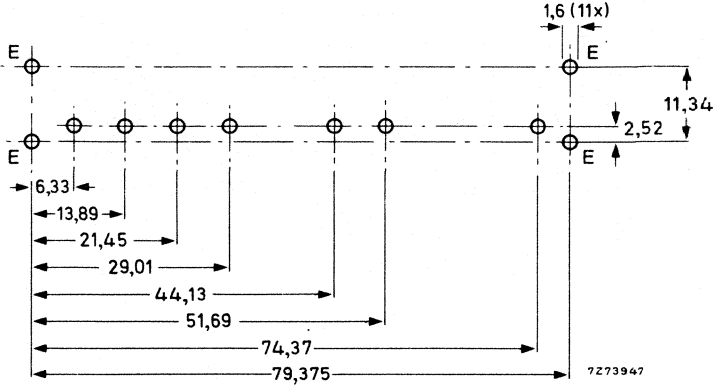

Fig. 3 Piercing diagram viewed from solder side of board.

For connection to the socket on the top of tuner U322LO a coaxial plug has to be used; type 3/2-50 (manufacturer: Daut und Rietz) is recommended.

ELECTRICAL DATA

The electrical values are measured on the u.h.f. tuner alone, but they are also valid for the u.h.f. tuner in combination with a v.h.f. tuner V311, V314 or V315. Unless otherwise specified all electrical values apply at an ambient temperature of 25 ± 5 °C, a relative humidity of $60 \pm 15\%$, a supply voltage of $12 \pm 0,3$ V and an a.g.c. voltage of $9,2 \pm 0,2$ V.

Within the given tolerance range of supply voltage and a.g.c. voltage only insignificant deviations from the specified values can be expected. Under the extreme conditions of temperature and humidity as given below, the tuner will function normally, but some specified limits may be exceeded.

General

Semiconductors

P-I-N diode	BA379
r.f. amplifier	BF480
mixer	BA280 (or MBD102)
oscillator	BF480
tuning diodes	3 x BB105B
i.f. amplifier	BF324

Ambient temperature range

operating	+ 5 to + 55 °C
storage	-25 to + 85 °C

Relative humidity

max. 90%

Voltages and currents

Supply voltage	+ 12 V \pm 10%
----------------	------------------

Note: The supply voltage at terminal 2 (input stage) should be filtered to avoid hum modulation in the P-I-N diode when the attenuator is biased to higher attenuation ratios.

Current drawn from + 12 V supply

r.f. amplifier, at nominal gain	typ. 13 mA
r.f. amplifier, at 30 dB gain reduction	typ. 4,5 mA
oscillator/i.f. amplifier	max. 16 mA

A.G.C. voltage (Fig. 4), at nominal gain + 9,2 \pm 0,5 V

A.G.C. voltage, at 30 dB gain reduction min. + 1,5 V

Note: A.G.C. voltages between 0 and + 10 V may be applied without risk of damage.

A.G.C. current (Fig. 4)

during gain control (0 to 30 dB)	max. + 1 mA
at nominal gain	typ. + 0,76 to + 0,97 mA
at 30 dB gain reduction	typ. + 0,20 mA



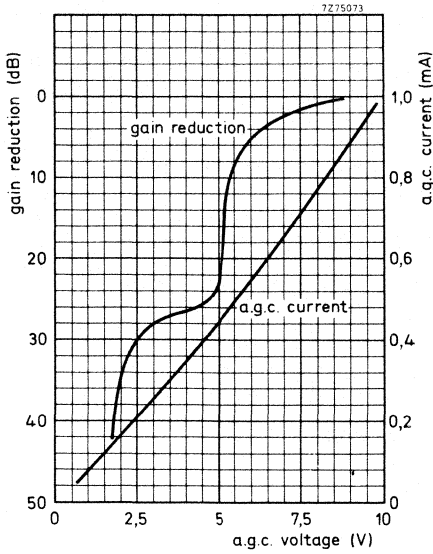

Fig. 4.

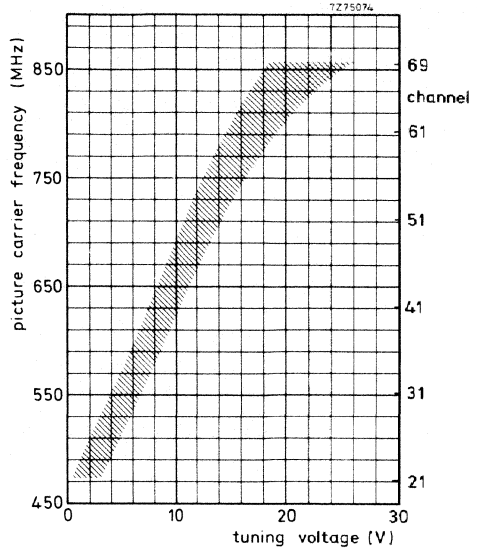

Fig. 5.

Tuning voltage range (Fig. 5)

Current drawn from + 28 V tuning voltage supply
at 25 °C
at 55 °C

Slope of tuning characteristic

Note: The source impedance of the tuning voltage offered to terminal 4 must be maximum 47 kΩ at tuning voltages below 3 V.

Oscillator sample signal; **only valid for U322LO**

at + 12 V supply voltage and

$T_{amb} = + 25 °C$

within the given tolerance range of supply voltage and given operating temperature range, and within the tuning voltage range + 0,5 to + 30 V

+ 1 to + 28 V

max. 0,25 μA

max. 1 μA

min. 4 MHz/V

typ. 90 dB (μV) into 75 Ω

min. 80 dB (μV) into 75 Ω

max. 100 dB (μV) into 75 Ω

Note: A tuning voltage higher than + 28 V will not be harmful for the tuner and may be applied at the user's own risk. Under this condition the published reverse voltage limit of the oscillator tuning diode will be exceeded; the oscillator frequency will never decrease with increasing tuning voltage.



Frequencies

Frequency range

channel E21 (picture carrier 471, 25 MHz) to channel E69 (picture carrier 855, 25 MHz). Margin at the extreme channels: min. 3 MHz.

Intermediate frequencies

picture

sound

systems G, H

systems I, K

38,9 MHz

39,5 MHz

33,4 MHz

33,5 MHz

The oscillator frequency is higher than the aerial signal frequency.

Note: The tuner is aligned in such a way that the i.f. frequencies of the four systems can be applied.

Wanted signal characteristics

Input impedance

asymmetrical

75 Ω

Input impedance of oscillator sample socket; only valid for U322LO

asymmetrical

75 Ω

V.S.W.R. and reflection coefficient

at picture carrier frequency, at

nominal gain

v.s.w.r.

max. 5

reflection coefficient

max. 66%

V.S.W.R. and reflection coefficient at oscillator sample socket; only valid for U322LO

v.s.w.r. at $f_{osc} < 600$ MHz

max. 4 (typ. 3)

v.s.w.r. at $f_{osc} > 600$ MHz

max. 3 (typ. 2)

reflection coefficient at $f_{osc} < 600$ MHz

max. 60% (typ. 50%)

reflection coefficient at $f_{osc} > 600$ MHz

max. 50% (typ. 33%)

R.F. curves, bandwidth

typ. 18 MHz

R.F. curves, tilt (only for i.f. 38,9/33,4 MHz)

on any channel the amplitude difference between the top of the r.f. resonant curve and the picture carrier marker, the sound carrier marker, or any frequency between them will not exceed 3 dB at nominal gain, and 4 dB in the a.g.c. range between nominal gain and 20 dB gain reduction.

A.G.C. range

min. 30 dB



Power gain (see also Measuring method of power gain)	min. 19 dB
channel E21	typ. 24 dB
channel E40	typ. 22 dB
channel E69	typ. 25 dB
Gain difference between any two channels	typ. 4 dB
Noise figure	max. 10 dB
channel E21	typ. 7 dB
channel E40	typ. 7,5 dB
channel E69	typ. 8 dB
Overloading	
Input signal producing 1 dB gain compression at nominal gain	typ. 90 dB (μV) into 75 Ω
Input signal producing either a detuning of the oscillator of + 300 kHz or -1000 kHz or stopping of the oscillations at nominal gain	typ. 100 dB (μV) into 75 Ω
Unwanted signal characteristics	
Image rejection (measured at picture carrier frequency)	
channels E21 to E60	min. 46 dB; typ. 53 dB
Harmonic content of oscillator sample; only valid for U322LO	
Suppression of harmonics which fall into the frequency range below 1200 MHz (second harmonics of fundamentals below 600 MHz)	min. 15 dB (typ. 20 dB) below oscillator fundamental
R.F. rejection at oscillator sample socket; only valid for U322LO	
Signal voltage at oscillator sample socket (input signals of wanted frequency 70 dB (μV) into 75 Ω ; tuner operating at nominal gain)	min. 17 dB (typ. 24 to 34 dB) below oscillator fundamental
I.F. rejection (measured at picture carrier and colour sub-carrier frequency)	min. 60 dB
I.F. rejection at oscillator sample socket; only valid for U322LO	
I.F. signals at oscillator sample socket (converted from input signals of wanted frequency 70 dB (μV) into 75 Ω ; tuner operating at nominal gain)	min. 20 dB (typ. 35 dB) below oscillator fundamental



N ± 4 rejection

Interference signal for an interference ratio of 53 dB referred to wanted picture carrier (picture to sound carrier ratio of 10 dB; wanted signal 60 dB (μV); tuner operating at nominal gain)

max. 92 dB (μV) into 75 Ω

Cross modulation

Input signal producing 1% cross modulation, i.e. 1% of the modulation depth of the interfering signal is transferred to the wanted signal.

In channel cross modulation (wanted signal: picture carrier frequency; interfering signal: sound carrier frequency)

at nominal gain (wanted input level 60 dB (μV))

typ. 80 dB (μV) into 75 Ω

at 26 dB gain reduction

(wanted input level 86 dB (μV))

typ. 100 dB (μV) into 75 Ω

In band cross modulation (wanted signal: picture carrier of channel N; interfering signal: picture carrier of channel N ± 5)

at nominal gain (wanted input level 60 dB (μV))

typ. 92 dB (μV) into 75 Ω

at 26 dB gain reduction

(wanted input level 86 dB (μV))

typ. 100 dB (μV) into 75 Ω

Out of band cross modulation, at nominal gain

v.h.f. I

min. 108 dB (μV) into 75 Ω

v.h.f. III

min. 108 dB (μV) into 75 Ω

Oscillator characteristics

Pulling

Input signal of tuned frequency producing a shift of the oscillator frequency of 10 kHz, at nominal gain

typ. 84 dB (μV) into 75 Ω

Shift of oscillator frequency

at a change of the supply voltage of 5%

max. 500 kHz



Drift of oscillator frequency

during warm-up time (after the tuner has been completely out of operation for 15 min, measured between 5 s and 15 min after switching on)

max. 250 kHz

during warm-up time (after the input stage is in operation for 15 min, measured between 2 s and 15 min after switching on the oscillator/i.f. stage)

max. 250 kHz

at a change of the ambient temperature from + 25 to + 40 °C (measured after 3 cycles from + 25 to + 55 °C)

470 to 790 MHz
790 to 860 MHz

max. 500 kHz
max. 650 kHz

I.F. circuit characteristics

Bandwidth of i.f. output circuit

5 ± 1 MHz

Note: I.F. output of the tuner terminated with the circuit shown in Fig. 6; tuning voltage 15 V.

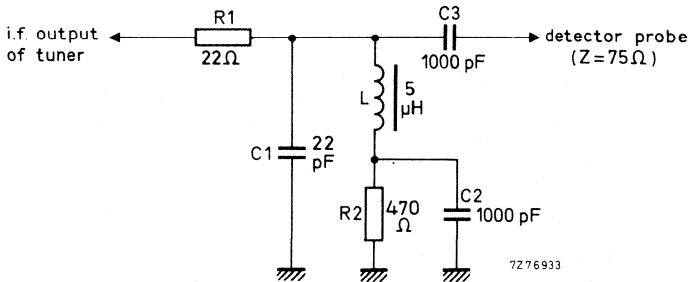

Fig. 6.

Bandwidth variation of i.f. output circuit as a result of r.f. tuning

max. 500 kHz

Note: I.F. output of the tuner terminated with a modified circuit of Fig. 6, i.e. a 100 pF capacitor is connected in parallel with C1 and R1 is short-circuited; tuning voltage 15 V.

Detuning of the i.f. output circuit as a result of r.f. tuning

max. 500 kHz

Note: I.F. output of the tuner terminated with a modified circuit of Fig. 6, i.e. a 100 pF capacitor is connected in parallel with C1 and R1 is short-circuited; tuning voltage 15 V.



Minimum tuning range of i.f. output coil 33 to 40 MHz

Note: I.F. output of the tuner terminated with the circuit shown in Fig. 6; tuning voltage 15 V.

Attenuation between i.f. injection point
and i.f. output of the tuner typ. 23 dB

Miscellaneous

Radio interference

Oscillator radiation and oscillator
voltage at the aerial terminal

Within the limits of C.I.S.P.R. 13
(1975) and VDE 0872/7.72.*
For the oscillator radiation use
is made of the relaxed limit of
3 mV/m (70 dB μ V/m).

Microphonics

There will be no microphonics,
provided the tuner is installed
in a professional manner.

Surge protection

Protection against voltages

max. 8 kV

Note: Three discharges of a 470 pF capacitor into the aerial terminal.

Protection against flashes

max. 30 kV, 400 mWs

Note: A flashover circuit producing flashes with frequencies of 1 to 20 Hz for 30 s is connected to the aerial terminal.

* For U322LO: when the oscillator sample socket is either open or terminated with a shielded resistor of 75 Ω .

ADDITIONAL INFORMATION

I.F. injection

The tuner is provided with an i.f. injection point at the collector of the i.f. transistor (coupled via a capacitor to terminal 7). The i.f. generator can be connected directly to this point (Fig. 7).

The tuner needs normal supply voltages and a tuning voltage of 15 V; the i.f. output should be loaded with the circuit shown in Fig. 6.

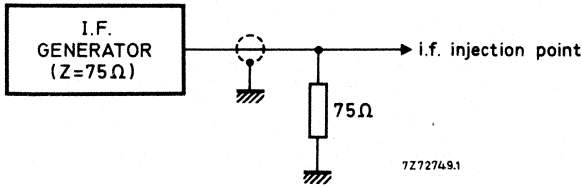

Fig. 7.

Connection of the i.f. amplifier

The tuner needs a d.c. path from the i.f. output terminal (10) to earth, preferably via a choke of approx. $5 \mu\text{H}$ outside the tuner (Fig. 8). Where the tuner is used in combination with a v.h.f. tuner, this choke can be common for both tuners; a resistor in series with the choke can make ineffective the i.f. output circuit of the switched-off tuner. For damping the i.f. output circuit and matching the i.f. output impedance of the tuner to the i.f. amplifier, a series resistor and a parallel capacitor as shown in Fig. 8 should be used.

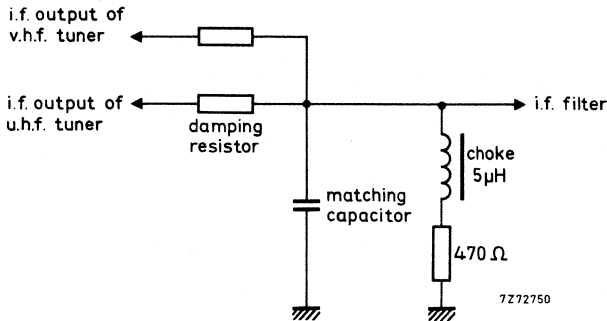

Fig. 8.



Measuring method of power gain

The i.f. output of the tuner should be terminated with the RC-circuit given in Fig. 6.

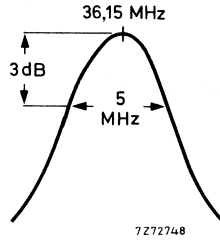

Fig. 9.

The RC-circuit roughly matches the i.f. output impedance to 75Ω at the resonant frequency of the i.f. output circuit, which should be tuned to 36,15 MHz; the bandwidth should be approx. 5 MHz (Fig. 9).

Because the input and output impedances of the tuner are now 75Ω , the power gain can be measured in the conventional manner by inserting tuner and RC-circuit between a 75Ω source and a 75Ω detector.

Alignment of the i.f. output coil

The i.f. output coil should be adjusted with a brass tool with a blade as shown in Fig. 10. A suitable tool is available under catalogue number 7122 005 47680.

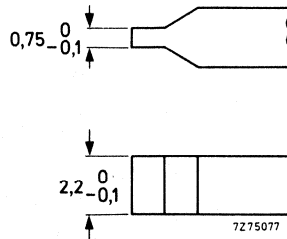

Fig. 10.

ACCESSORIES

Connector assembly for use of tuner U322 or U322LO in combination with v.h.f. tuner V311 (or VD1), V314 or V315: connector, catalogue number 3112 200 20720;

washer, catalogue number 3112 221 01220;

clamp, catalogue number 3112 274 13220.

V.H.F. TELEVISION TUNER

- with diode tuning

QUICK REFERENCE DATA

Systems	C.C.I.R. systems B and I	
	system B	system I
Channels		
v.h.f. I	NZ1 to E4	IA to IC
v.h.f. III	E5 to E12	ID to IJ
Intermediate frequencies		
picture	38,9 MHz	39,5 MHz
sound	33,4 MHz	33,5 MHz

APPLICATION

This tuner is designed to cover the v.h.f. channels of C.C.I.R. systems B and I. In combination with the u.h.f. tuner U322 it can be used in v.h.f./u.h.f. receivers. The aerial inputs and i.f. outputs of both tuners can then be connected in parallel without additional circuitry.



DESCRIPTION

The V311 is a v.h.f. tuner with electronic tuning, covering the v.h.f. band I (44 to 68 MHz) and the v.h.f. band III (174 to 230 MHz). Switching between the bands is done automatically by a built-in comparator circuit.

Mechanically, the tuner is built on a printed-wiring board, carrying all components, in a metal housing made of a rectangular frame and front and rear cover (see Fig. 2). All connections (aerial, supply voltage, a.g.c. voltage, tuning voltage, i.f. injection, i.f. output) are made via terminals on the under side. The mounting method is shown in Fig. 3.

Electrically the tuner consists of two input circuits in parallel (bands I and III) with band-pass characteristics, followed by a p-i-n diode attenuator (2 diodes BA379) and the input transistor AF379 in grounded-base configuration. This transistor operates at an emitter current of about 4 to 12 mA, featuring good noise figures and good signal handling properties. It also supplies the current drive for the p-i-n diode attenuator, controlled by an a.g.c. voltage fed to the transistor's base. This combination has good signal handling properties throughout the a.g.c. range.

The collector load of the input transistor is formed by a double tuned circuit, transferring the signal to the self-oscillating mixer AF367. The selectivity of this circuit at the intermediate frequency has been improved.

Four capacitance diodes BB106 tune the double-tuned circuit and the oscillator.

The i.f. output circuit of the tuner is a single tuned one, at the low end of which the i.f. signal is coupled out of the tuner. A d.c. path to earth for the collector current of the mixer has to be provided outside the tuner, preferably by a choke of about 5 μ H. Damping of the i.f. output circuit and matching of the i.f. output to the i.f. circuit of the receiver can be achieved by connecting a series resistance and a parallel capacitance outside the tuner.

An i.f. injection point has been provided at the collector of the mixer transistor, connected to terminal S.

A comparator circuit supplying the automatic switching-over between bands I and III consists of two p-n-p transistors, the emitters of which have the same stabilized 5,6 V reference voltage, thereby supplying a very good temperature and supply voltage dependence. The voltage divider at the input of the circuit consists of two high-ohmic resistors to prevent unacceptable loading of the tuning voltage.

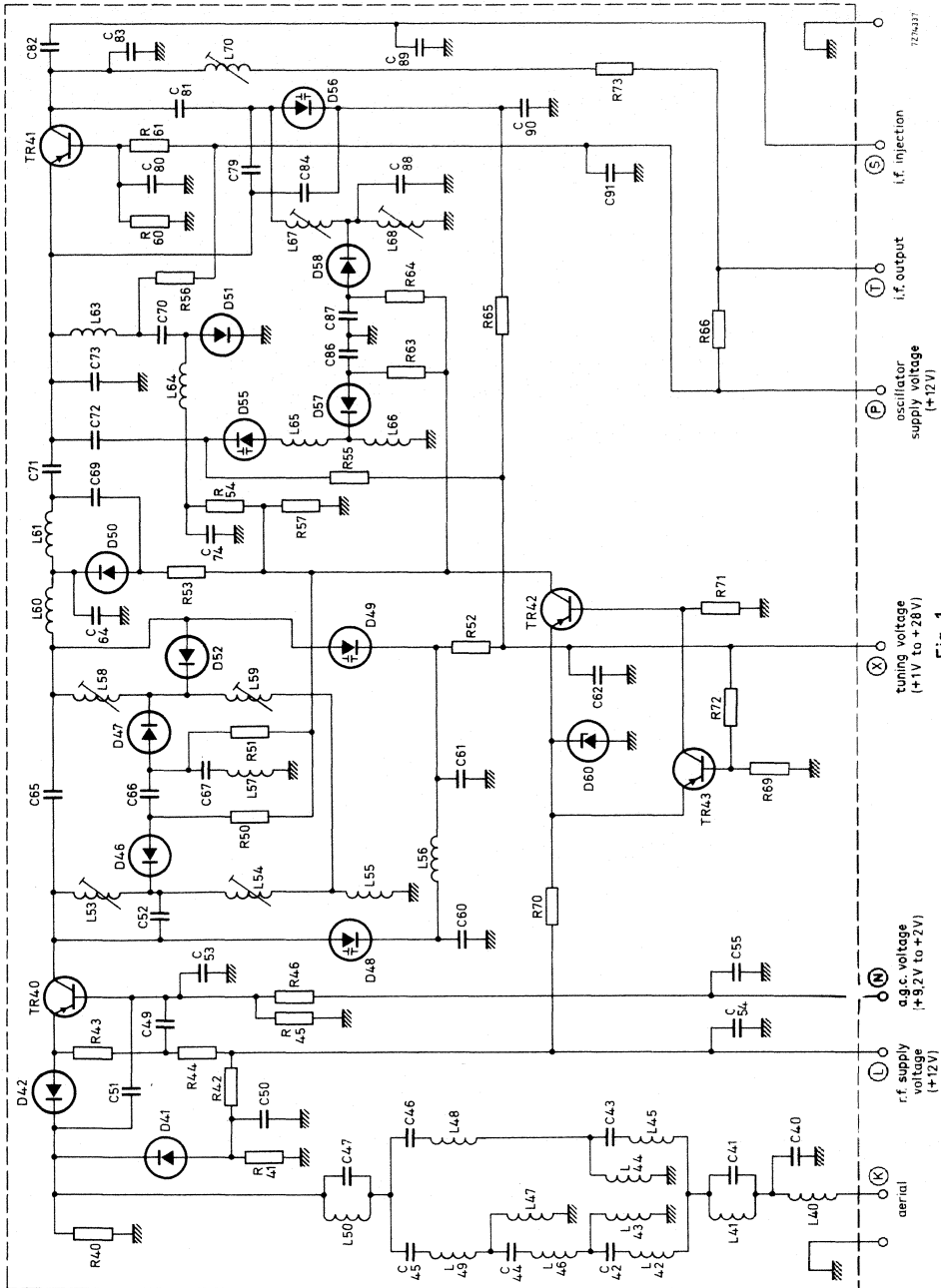

MECHANICAL DATA

Dimensions in mm

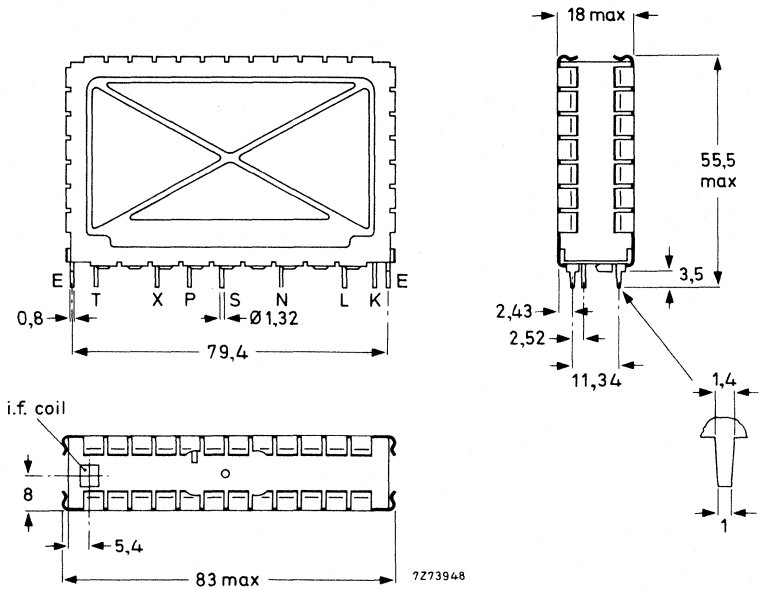

Fig. 2a.

Terminal T = i.f. output

X = tuning voltage, + 1 to + 28 V

P = self-oscillating mixer supply voltage, + 12 V

S = i.f. injection point

N = a.g.c. voltage, + 9,2 to + 2 V

L = r.f. supply voltage, + 12 V

K = aerial

Note

When the tuner is operated together with a u.h.f. tuner, only the supply voltage at terminal P should be switched off during u.h.f. operation.

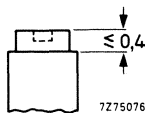

Fig. 2b I.F. output coil.

Torque for alignment: 2 to 15 mNm

Press-through force: ≥ 10 N

Mass

approx. 80 g

Mounting

The tuner may be mounted by soldering it on to a printed-wiring board, using the piercing diagram shown in Fig. 3. (The tuner may also be mounted by means of a socket. Information will be supplied upon request).

It is recommended that the tuner be installed in the cool part of the receiver cabinet and not exposed to the vibrations of the loudspeaker. There are no restrictions on orientation.

The solderability of the terminals and mounting tabs is according to IEC 68-2, test Ta ($230 \pm 10 \text{ }^\circ\text{C}$, $2 \pm 0,5 \text{ s}$). The resistance to soldering heat is according to IEC 68-2, test Tb ($260 \pm 5 \text{ }^\circ\text{C}$, $10 \pm 1 \text{ s}$).

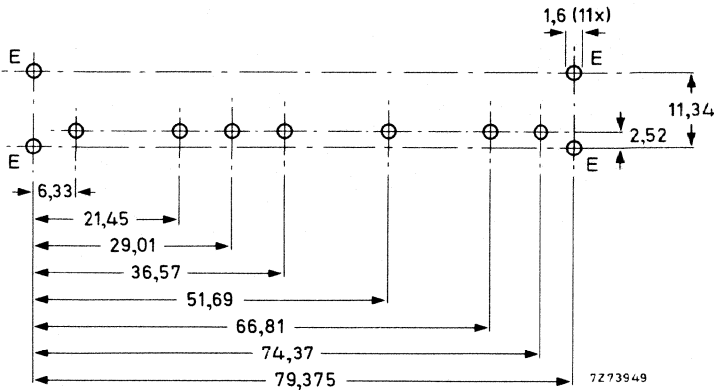

Fig. 3 Piercing diagram viewed from solder side of board.



ELECTRICAL DATA

The electrical values are measured on the v.h.f. tuner alone, but they are also valid for the v.h.f. tuner in combination with a u.h.f. tuner U322.

Unless otherwise specified all electrical values apply at an ambient temperature of 25 ± 5 °C, a relative humidity of $60 \pm 15\%$, a supply voltage of $12 \pm 0,3$ V and an a.g.c. voltage of $9,2 \pm 0,2$ V.

Within the given tolerance range of supply voltage and a.g.c. voltage only insignificant deviations from the specified values can be expected.

Under the extreme conditions of temperature and humidity as given below, the tuner will function normally, but some specified limits may be exceeded.

General**Semiconductors**

p-i-n diodes	2 x BA379
r.f. amplifier	AF379
self-oscillating mixer	AF367
tuning diodes	4 x BB106
switching diodes	BA220; 6 x BA243
bandswitch comparator	BZX79; 2 x BC558

Ambient temperature range

operating	+ 5 to + 55 °C
storage	-25 to + 85 °C

Relative humidity

max. 90%

Voltages and currents

Supply voltage	+ 12 V \pm 10%
----------------	------------------

Note

The supply voltage at terminal L (input stage) should be filtered to avoid hum modulation in one of the p-i-n diodes when the attenuator is biased to higher attenuation ratios.

Current drawn from + 12 V supply

r.f. amplifier + bandswitch circuit	
v.h.f. I, at nominal gain	typ. 40 mA
at 40 dB gain reduction	typ. 42 mA
v.h.f. III, at nominal gain	typ. 40 mA
at 40 dB gain reduction	typ. 42 mA
self-oscillating mixer	typ. 4,5 mA

Bandswitching

Switching between v.h.f. I and v.h.f. III is done automatically within the tuner. If the tuner operates together with a u.h.f. tuner only the supply voltage at terminal P should be switched off during u.h.f. operation.

A.G.C. voltage (Figs 4, 5 and 6)
 at nominal gain
 at 40 dB gain reduction

+ 9,2 ± 0,5 V
 min. + 2 V

Note

A.G.C. voltages between 0 and + 10 V may be applied without risk of damage.

A.G.C. current (Fig. 7), during gain control
 (0 to 40 dB)
 at nominal gain
 at 40 dB gain reduction

max. + 1 mA
 typ. + 0,8 mA
 typ. + 0,2 mA

Tuning voltage range (Fig. 8)

+ 1 to + 28 V
 -4 to + 11 μA

Current drawn from + 28 V tuning voltage supply (Fig. 9)

Note

The source impedance of the tuning voltage offered to terminal X must be max. 47 kΩ.

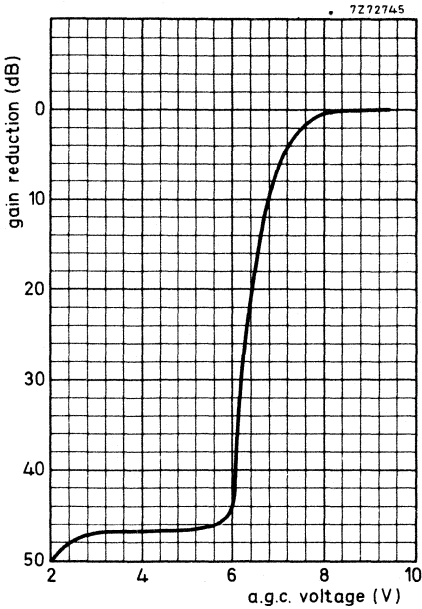

Fig. 4 A.G.C. voltage characteristic, channel E2; typical curve.

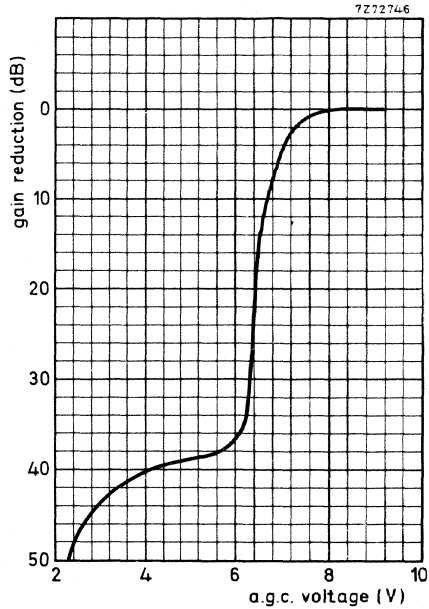

Fig. 5 A.G.C. voltage characteristic, channel E5; typical curve.



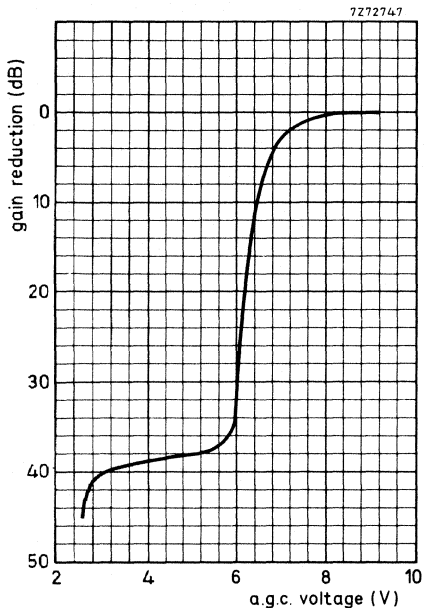

Fig. 6 A.G.C. voltage characteristic, channel E12; typical curve.

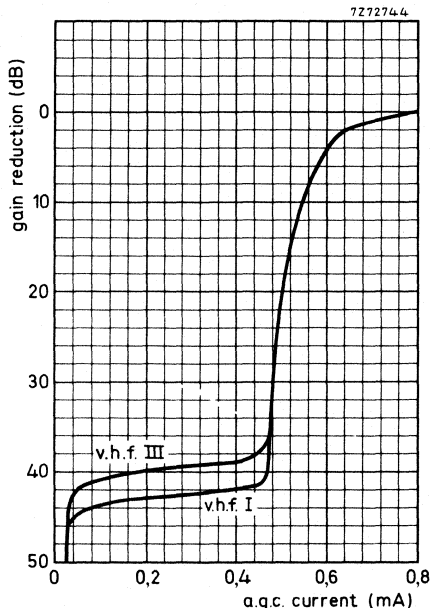

Fig. 7 A.G.C. current characteristic; typical curves.

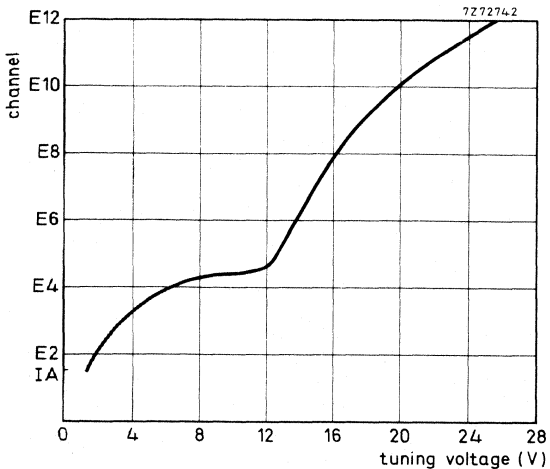

Fig. 8 Tuning voltage characteristic; typical curve.

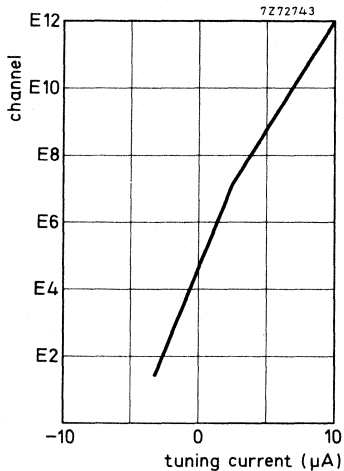

Fig. 9 Tuning current characteristic; typical curve.

Frequencies

Frequency ranges

v.h.f. I

channel NZ1 (picture carrier 45,25 MHz)
to channel E4 (picture carrier 62,25 MHz).

Margin at the extreme channels: min. 1 MHz.

v.h.f. III

channel E5 (picture carrier 175,25 MHz)
to channel E12 (picture carrier 224,25 MHz).

Margin at the extreme channels: min. 1,5 MHz.

Intermediate frequencies

picture

system B

system I

sound

38,9 MHz

39,5 MHz

33,4 MHz

33,5 MHz

The oscillator frequency is higher than the aerial signal frequency.

Note

The tuner is aligned in such a way that the i.f. frequencies of both systems can be applied.

Wanted signal characteristics

Input impedance, asymmetrical

75 Ω

minimum value
between picture
carrier and sound
carrier frequency

maximum value
at picture carrier
frequency

V.S.W.R.

max. 4

max. 4

Reflection coefficient

max. 60%

max. 60%

A.G.C. range

min. 40 dB

R.F. curves

bandwidth

typ. 10 MHz

tilt (only for i.f. 38,9/33,4 MHz)

on any channel the amplitude difference between the top of the r.f. resonant curve and the picture carrier marker, the sound carrier marker, or any frequency between them will not exceed 3 dB at nominal gain, and 4 dB in the a.g.c. range between nominal gain and 20 dB gain reduction.

Power gain (see also 'Measuring method of power gain')

channel E3

min. 20 dB

channel E5

typ. 25 dB

channel E12

typ. 25 dB

typ. 26 dB

Gain difference between any two channels

typ. 4 dB

Noise figure

channel E3

max. 9 dB

channel E5

typ. 5 dB

channel E12

typ. 6,5 dB

typ. 7 dB



Overloading

Input signal producing 1 dB gain compression at nominal gain typ. 88 dB (μ V) into 75 Ω

Input signal producing either a detuning of the oscillator of + 300 kHz or - 1000 kHz or stopping of the oscillations at nominal gain typ. 90 dB (μ V) into 75 Ω

Unwanted signal characteristics

Image rejection (measured at picture carrier frequency) min. 53 dB

I.F. rejection (measured at picture carrier frequency) channel IA to E12 min. 60 dB

Note

At colour sub-carrier frequency max. 6 dB less rejection.

Cross-modulation

Input signal producing 1% cross-modulation, i.e. 1% of the modulation depth of the interfering signal is transferred to the wanted signal.

In channel cross-modulation (wanted signal: picture carrier frequency; interfering signal: sound carrier frequency)

at nominal gain (wanted input level 60 dB (μ V)) typ. 70 dB (μ V) into 75 Ω

at 40 dB gain reduction (wanted input level 100 dB (μ V)) typ. 106 dB (μ V) into 75 Ω

In band cross-modulation (wanted signal: picture carrier of channel N; interfering signal: picture carrier of channel N \pm 2 for v.h.f. I or channel N \pm 3 for v.h.f. III)

at nominal gain (wanted input level 60 dB (μ V)) typ. 94 dB (μ V) into 75 Ω

at 40 dB gain reduction (wanted input level 100 dB (μ V)) typ. 100 dB (μ V) into 75 Ω

Out of band cross-modulation at nominal gain

v.h.f. I, interfering from v.h.f. III typ. 92 dB (μ V) into 75 Ω
interfering from u.h.f. typ. 100 dB (μ V) into 75 Ω

v.h.f. III, interfering from v.h.f. I typ. 100 dB (μ V) into 75 Ω
interfering from u.h.f. typ. 100 dB (μ V) into 75 Ω

Oscillator characteristics

Pulling

Input signal of tuned frequency producing a shift of the oscillator frequency of 10 kHz, at nominal gain
 v.h.f. I
 v.h.f. III

typ. 73 dB (μV) into 75 Ω
 typ. 73 dB (μV) into 75 Ω

Shift of oscillator frequency at a change of the supply voltage of 5%

max. 250 kHz

Drift of oscillator frequency during warm-up time (after the tuner has been completely out of operation for 15 min, measured between 5 s and 15 min after switching on)

max. 250 kHz

during warm-up time (after the input stage is in operation for 15 min, measured between 2 s and 15 min after switching on the self-oscillating mixer stage)

max. 250 kHz

at a change of the ambient temperature from + 25 to + 40 $^{\circ}\text{C}$ (measured after 3 cycles from + 25 to + 55 $^{\circ}\text{C}$)

max. 300 kHz

I.F. circuit characteristics

Bandwidth of i.f. output circuit *

5 MHz

Bandwidth variation of i.f. output circuit as a result of r.f. tuning and bandswitching (reference: v.h.f. III)

max. 350 kHz

Note

I.F. output of the tuner terminated with a modified circuit of Fig. 10, i.e. a 100 pF capacitor is connected in parallel with C1 and R1 is short-circuited; tuning voltage is 15 V.

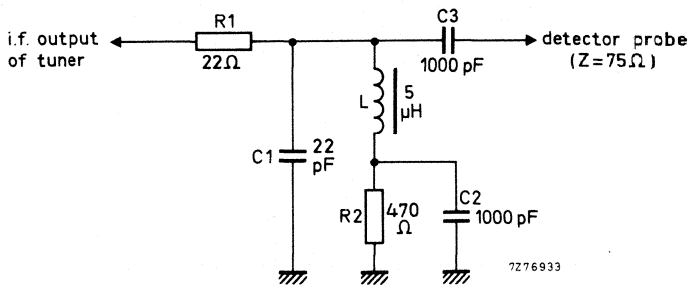

Fig. 10.

* I.F. output of the tuner terminated with the circuit shown in Fig. 10; tuning voltage is 15 V.



Detuning of the i.f. output circuit as a result of r.f. tuning and bandswitching (reference; v.h.f. III), excluded channel E2 channel E2

max. 350 kHz
max. 450 kHz

Note

I.F. output of the tuner terminated with a modified circuit of Fig. 10, i.e. a 100 pF capacitor is connected in parallel with C1 and R1 is short-circuited; tuning voltage is 15 V.

Tuning range of i.f. output coil *

max. 34 to min. 41 MHz

Attenuation between i.f. injection point and i.f. output of the tuner

typ. 23 dB

Miscellaneous

Radio interference

Oscillator radiation and oscillator voltage at the aerial terminal

Within the limits of C.I.S.P.R. 24/3 (1970) and VDE 0872/7.72. For the oscillator radiation above 200 MHz use is made of the relaxed limit of 2 mV/m (66 dB μ V/m).

Microphonics

There will be no microphonics, provided the tuner is installed in a professional manner.

Surge protection

Protection against voltages

max. 8 kV

Note

Three discharges of a 470 pF capacitor into the aerial terminal.

Protection against flashes

max. 30 kV, 400 mWs

Note

A flashover circuit producing flashes with frequencies of 1 to 20 Hz for 30 s is connected to the aerial terminal.

* I.F. output of the tuner terminated with the circuit shown in Fig. 10; tuning voltage is 15 V.

ADDITIONAL INFORMATION

If the tuner is used in receivers designed for v.h.f. only, a capacitor of 5,6 pF should be applied between the aerial input and earth.

I.F. injection

The tuner is provided with an i.f. injection point at the collector of the mixer transistor (coupled via a capacitor to terminal S). The i.f. generator can be connected directly to this point (Fig. 11).

The tuner needs normal supply voltages and a tuning voltage of 15 V; the i.f. output should be loaded with the circuit shown in Fig. 10.

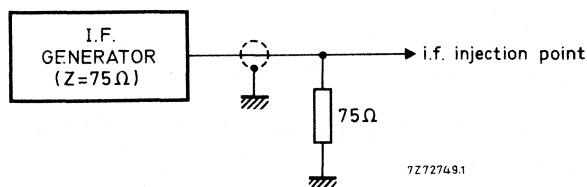

Fig. 11.

Connection of the i.f. amplifier

The tuner needs a d.c. path from the i.f. output terminal (T) to earth, preferably via a choke of approx. 5 μ H outside the tuner (Fig. 12).

In the case where the tuner is used in combination with a u.h.f. tuner, this choke can be common for both tuners; a resistor in series with the choke can make ineffective the i.f. output circuit of the switched off tuner. For damping the i.f. output circuit and matching the i.f. output impedance of the tuner to the i.f. amplifier, a series resistor and a parallel capacitor as shown in Fig. 12 should be used.

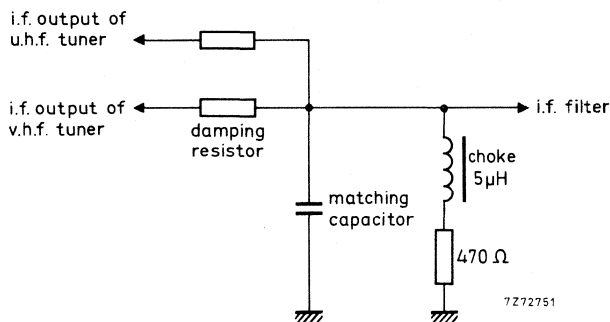

Fig. 12.



Measuring method of power gain

The i.f. output of the tuner should be terminated with the RC-circuit given in Fig. 10.

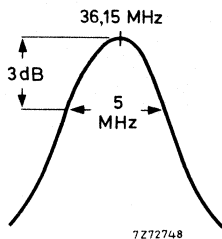

Fig. 13.

The RC-circuit roughly matches the i.f. output impedance to 75Ω at the resonant frequency of the i.f. output circuit, which should be tuned to 36,15 MHz; the bandwidth should be approx. 5 MHz (Fig. 13).

Because the input and output impedances of the tuner are now 75Ω , the power gain can be measured in the conventional manner by inserting tuner and RC-circuit between a 75Ω source and a 75Ω detector.

Alignment of the i.f. output coil

The i.f. output coil should be adjusted with a brass tool with a blade as shown in Fig. 14. A suitable tool is available under catalogue number 7122 009 47680.

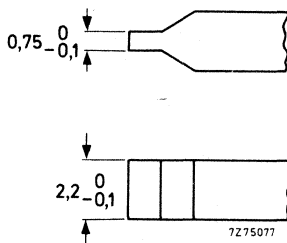

Fig. 14.

ACCESSORIES

Connector assembly for use of tuner V311 in combination with u.h.f. tuner U322:
 connector, catalogue number 3112 200 20720;
 washer, catalogue number 3112 221 01220;
 clamp, catalogue number 3112 274 13220.

V.H.F TELEVISION TUNER

QUICK REFERENCE DATA

Systems	C.C.I.R. systems B and G
Channels	
v.h.f. I	E2 to C
v.h.f. III	Morocco 4 to E12
Intermediate frequencies	
picture	38,9 MHz
sound	33,4 MHz

APPLICATION

This tuner is designed to cover the v.h.f. channels of C.C.I.R. systems B and G, including the Italian and Moroccan channels.

In combination with the u.h.f. tuner U322 it can be used in v.h.f./u.h.f. receivers. The aerial inputs and i.f. outputs of both tuners can then be connected in parallel without additional circuitry.

The tuner is compatible with tuner V315. It is also compatible with tuner V311 except for the band switching.



DESCRIPTION

The V314 is a v.h.f. tuner with electronic tuning, covering the v.h.f. band I (47 to 88 MHz) and the v.h.f. band III (162 to 230 MHz). Switching between the bands is done by connecting the supply voltage to terminal V for band I and to terminal P for band III.

Mechanically, the tuner is built on a printed-wiring board, carrying all components, in a metal housing made of a rectangular frame and front and rear cover (see Fig. 2a). All connections (aerial, supply voltage, a.g.c. voltage, tuning voltage, i.f. injection, i.f. output) are made via terminals on the underside. The mounting method is shown in Fig. 3.

Electrically the tuner consists of two input circuits in parallel (bands I and III) with band-pass characteristics, followed by a P-I-N diode attenuator (2 diodes BA379) and the input transistor AF379 in grounded-base configuration. This transistor operates at an emitter current of about 4 to 12 mA, featuring good noise figures and good signal handling properties. It also supplies the current drive for the P-I-N diode attenuator, controlled by an a.g.c. voltage fed to the transistor's base. This combination has good signal handling properties throughout the a.g.c. range. The collector load of the input transistor is formed by a double tuned circuit, transferring the signal to the self-oscillating mixer AF367. The selectivity of this circuit at the intermediate frequency has been improved. Three capacitance diodes BB106 tune the double tuned circuit and the oscillator.

The i.f. output circuit of the tuner is a single tuned one, at the low end of which the i.f. signal is coupled out of the tuner. A d.c. path to earth for the collector current of the mixer has to be provided outside the tuner, preferably by a choke of about 5 μ H. Damping of the i.f. output circuit and matching of the i.f. output to the i.f. circuit of the receiver can be achieved by connecting a series resistance and a parallel capacitance outside the tuner.

An i.f. injection point has been provided at the collector of the mixer transistor, connected to terminal S.

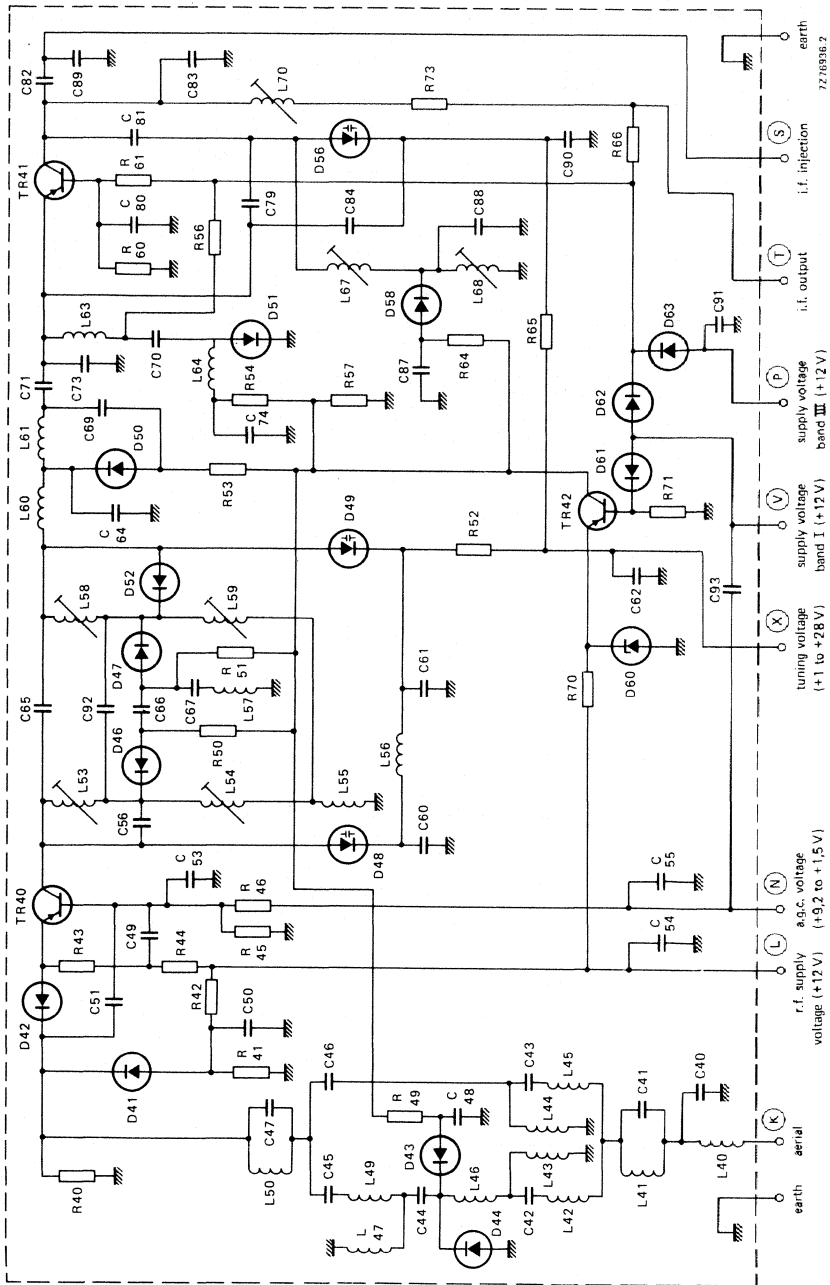

Fig. 1.



MECHANICAL DATA

Dimensions in mm

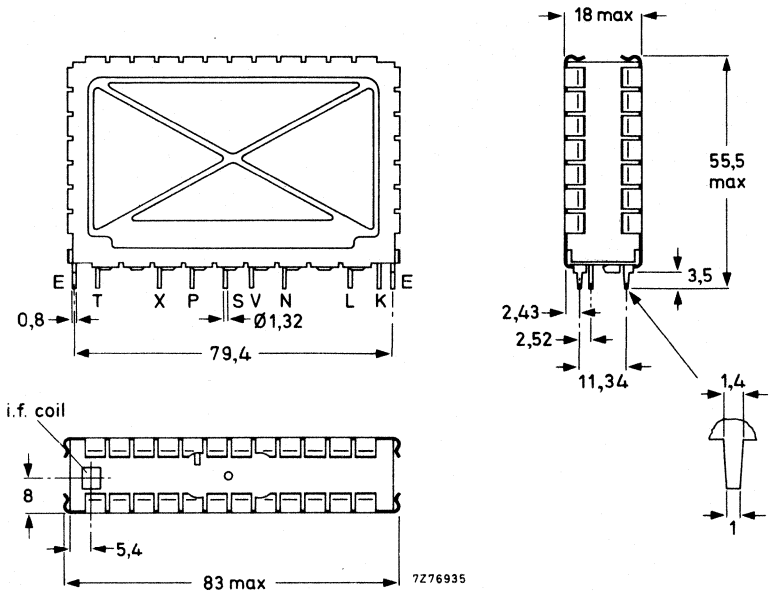

Fig. 2a.

- Terminal T = i.f. output
- X = tuning voltage, + 1 to + 28 V
- P = supply voltage, band III, + 12 V
- S = i.f. injection point
- V = supply voltage, band I, + 12 V
- N = a.g.c. voltage, + 9,2 to + 1,5 V
- L = r.f. stage supply voltage, + 12 V
- K = aerial

Note: When the tuner is operated together with a u.h.f. tuner, only the supply voltage at terminals P and V should be switched off during u.h.f. operation.

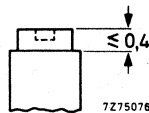

Fig. 2b I.F. output coil.
Torque for alignment: 2 to 15 mNm
Press-through force : ≥ 10 N

Mass approx. 80 g

Mounting

The tuner may be mounted by soldering it on to a printed-wiring board, using the piercing diagram shown in Fig. 3. (The tuner may also be mounted by means of a socket. Information will be supplied upon request.)

It is recommended that the tuner be installed in the cool part of the receiver cabinet and not exposed to the vibrations of the loudspeaker. There are no restrictions on orientation.

The solderability of the terminals and mounting tabs is according to IEC 68-2, test Ta ($230 \pm 10 \text{ }^\circ\text{C}$, $2 \pm 0,5 \text{ s}$). The resistance to soldering heat is according to IEC 68-2, test Tb ($260 \pm 5 \text{ }^\circ\text{C}$, $10 \pm 1 \text{ s}$).

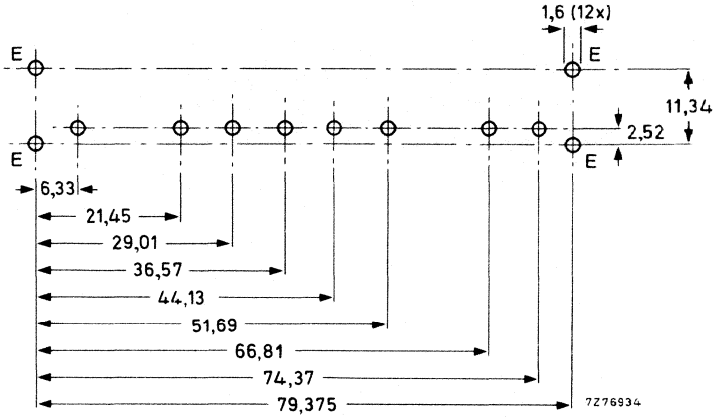

Fig. 3 Piercing diagram viewed from solder side of board.

ELECTRICAL DATA

The electrical values are measured on the v.h.f. tuner alone, but they are also valid for the v.h.f. tuner in combination with a u.h.f. tuner U322. Unless otherwise specified all electrical values apply at an ambient temperature of 25 ± 5 °C, a relative humidity of $60 \pm 15\%$, a supply voltage of $12 \pm 0,3$ V and an a.g.c. voltage of $9,2 \pm 0,2$ V.

Within the given tolerance range of supply voltage and a.g.c. voltage only insignificant deviations from the specified values can be expected. Under the extreme conditions of temperature and humidity as given below, the tuner will function normally, but some specified limits may be exceeded.

General**Semiconductors**

P-I-N diodes	2 x BA379
r.f. amplifier	AF379
self-oscillating mixer	AF367
tuning diodes	3 x BB106
switching diodes	4 x BA220; 6 x BA243
switching transistor	BC558
voltage regulator diode	BZX79 – C5V6

Ambient temperature range

operating	+ 5 to + 55 °C
storage	-25 to + 85 °C

Relative humidity

max 90%

Voltages and currents

Supply voltage	+ 12 V \pm 10%
----------------	------------------

Note: The supply voltage at terminals P and V should be filtered.

Current drawn from + 12 V supply

r.f. amplifier, v.h.f. I, at nominal gain	typ. 40 mA
v.h.f. I, at 40 dB gain reduction	typ. 42 mA
r.f. amplifier, v.h.f. III, at nominal gain	typ. 40 mA
v.h.f. III, at 40 dB gain reduction	typ. 42 mA
self-oscillating mixer, terminal P	typ. 3,7 mA
terminal V	typ. 4,4 mA

Band switching

For operation in band I the supply voltage must be connected to terminal V, for band III operation to terminal P. If the tuner operates together with a u.h.f. tuner only the supply voltage at terminals P and V should be switched off during u.h.f. operation.

A.G.C. voltage (Figs 4 to 7)
 at nominal gain $+9,2 \pm 0,5$ V
 at 40 dB gain reduction min. $+1,5$ V

Note: A.G.C. voltages between 0 and + 10 V may be applied without risk of damage.

A.G.C. current
 during gain control (0 to 40 dB)
 at nominal gain max. $+1$ mA
 at 40 dB gain reduction typ. $+0,8$ mA
 at 40 dB gain reduction typ. $+0,2$ mA

Tuning voltage range (Figs 8 and 9) $+1$ to $+28$ V

Current drawn from $+28$ V tuning voltage supply
 at 25 °C max. 150 nA
 at 55 °C max. 600 nA

Note: The source impedance of the tuning voltage offered to terminal X must be maximum 47 k Ω .

Switching current max. 16 mA

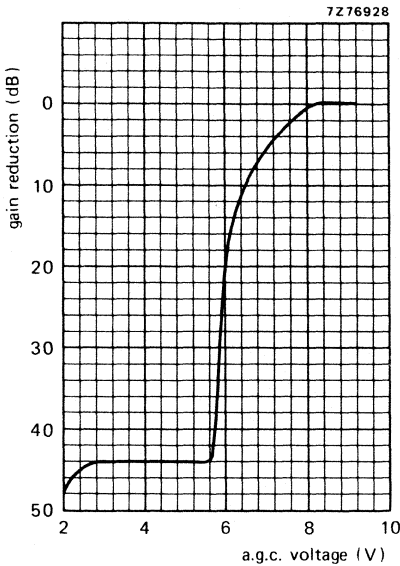

Fig. 4 A.G.C. voltage characteristic, channel E2; typical curve.

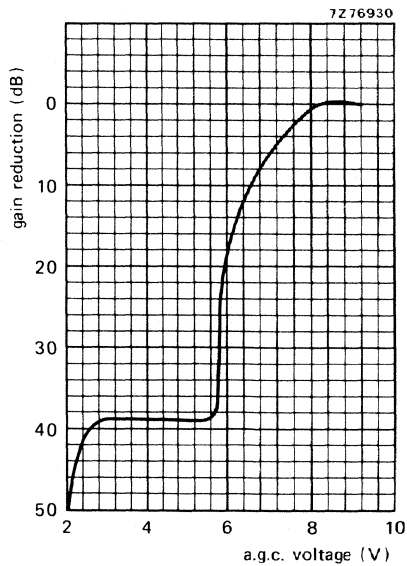

Fig. 5 A.G.C. voltage characteristic, channel C; typical curve.



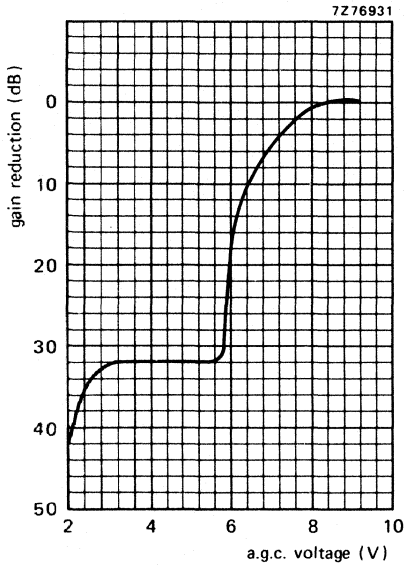

Fig. 6 A.G.C. voltage characteristic, channel M4; typical curve.

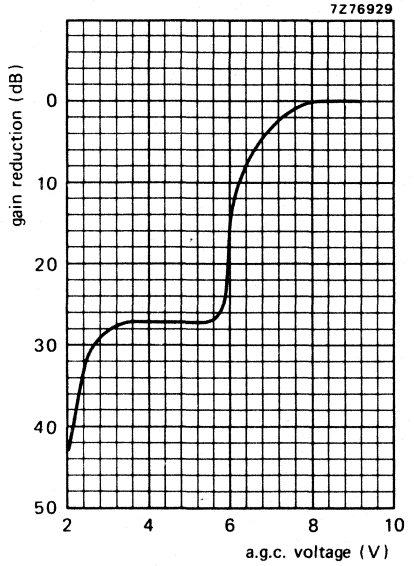

Fig. 7 A.G.C. voltage characteristic, channel E12; typical curve.

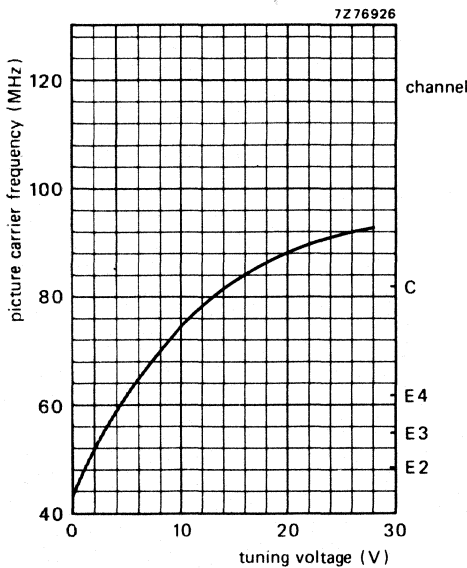

Fig. 8 Tuning voltage characteristic, v.h.f. I; typical curve.

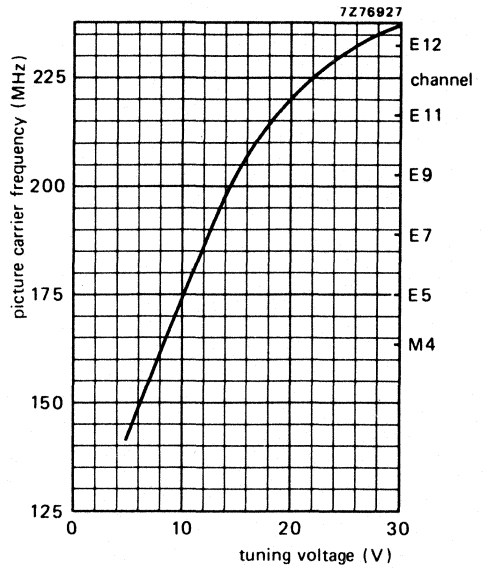

Fig. 9 Tuning voltage characteristic, v.h.f. III; typical curve.

Frequencies**Frequency ranges**

v.h.f. I

channel E2 (picture carrier 48,25 MHz)
to channel C (picture carrier 82,25 MHz)
Margin at the extreme channels: min. 1 MHz.

v.h.f. III

channel M4 (picture carrier 163,25 MHz)
to channel E12 (picture carrier 224,25 MHz)
Margin at the extreme channels: min. 1 MHz.

Intermediate frequencies

picture

38,9 MHz

sound

33,4 MHz

The oscillator frequency is higher than the
aerial signal frequency.

Wanted signal characteristics**Input impedance**

asymmetrical

75 Ω

minimum value
between picture
carrier and sound
carrier frequency

maximum value
at picture carrier
frequency

max. 4

max. 4

max. 60%

max. 60%

V.S.W.R.**Reflection coefficient****R.F. curves, bandwidth****R.F. curves, tilt**

typ. 12 MHz

on any channel the amplitude difference
between the top of the r.f. resonant curve
and the picture carrier marker, the sound
carrier marker, or any frequency between
them will not exceed 3 dB at nominal gain,
and 4 dB in the a.g.c. range between
nominal gain and 20 dB gain reduction.

A.G.C. range

min. 40 dB

Power gain (see also Measuring method of power gain)

channel E3

min. 20 dB

channel E5

typ. 26 dB

channel E12

typ. 25 dB

typ. 25 dB

Gain difference between any two channels

typ. 4 dB



Noise figure	max.	9 dB
channel E3	typ.	5 dB
channel E5	typ.	6,5 dB
channel E12	typ.	7 dB

Overloading

Input signal producing 1 dB gain compression at nominal gain

	typ.	88 dB (μ V) into 75 Ω
--	------	-----------------------------------

Input signal producing either a detuning of the oscillator of + 300 kHz or -1000 kHz or stopping of the oscillations at nominal gain

	typ.	90 dB (μ V) into 75 Ω
--	------	-----------------------------------

Unwanted signal characteristics

Image rejection (measured at picture carrier frequency)

	min.	53 dB
--	------	-------

I.F. rejection (measured at picture carrier frequency)

channel E2 to E12	min.	60 dB
-------------------	------	-------

Note: At colour sub-carrier frequency maximum 6 dB less rejection.

Cross modulation

Input signal producing 1% cross modulation, i.e. 1% of the modulation depth of the interfering signal is transferred to the wanted signal.

In channel cross modulation (wanted signal: picture carrier frequency; interfering signal: sound carrier frequency)

at nominal gain (wanted input level 60 dB (μ V))	typ.	70 dB (μ V) into 75 Ω
---	------	-----------------------------------

at 40 dB gain reduction (wanted input level 100 dB (μ V))	typ.	106 dB (μ V) into 75 Ω
--	------	------------------------------------

In band cross modulation (wanted signal: picture carrier of channel N; interfering signal: picture carrier of channel $N \pm 2$ for v.h.f. I or channel $N \pm 3$ for v.h.f. III)

at nominal gain (wanted input level 60 dB (μ V))	typ.	88 dB (μ V) into 75 Ω
---	------	-----------------------------------

at 40 dB gain reduction (wanted input level 100 dB (μ V))	typ.	100 dB (μ V) into 75 Ω
--	------	------------------------------------

Out of band cross modulation at nominal gain

v.h.f. I, interfering from v.h.f. III	typ.	92 dB (μ V) into 75 Ω
---------------------------------------	------	-----------------------------------

v.h.f. I, interfering from u.h.f.	typ.	100 dB (μ V) into 75 Ω
-----------------------------------	------	------------------------------------

v.h.f. III, interfering from v.h.f. I	typ.	100 dB (μ V) into 75 Ω
---------------------------------------	------	------------------------------------

v.h.f. III, interfering from u.h.f.	typ.	100 dB (μ V) into 75 Ω
-------------------------------------	------	------------------------------------

Oscillator characteristics

Pulling

Input signal of tuned frequency producing a shift of the oscillator frequency of 10 kHz, at nominal gain

v.h.f. I
v.h.f. III

typ. 73 dB (μV) into 75 Ω

typ. 73 dB (μV) into 75 Ω

Shift of oscillator frequency

at a change of the supply voltage of 5%

max. 250 kHz

Drift of oscillator frequency

during warm-up time (after the tuner has been completely out of operation for 15 min, measured between 5 s and 15 min after switching on)

max. 250 kHz

during warm-up time (after the input stage is in operation for 15 min, measured between 2 s and 15 min after switching on the self-oscillating mixer stage)

max. 250 kHz

at a change of the ambient temperature from + 25 to + 40 $^{\circ}\text{C}$ (measured after 3 cycles from + 25 to + 55 $^{\circ}\text{C}$)

max. 300 kHz

I.F. circuit characteristics

Bandwidth of i.f. output circuit

6 MHz

Note: I.F. output of the tuner terminated with the circuit shown in Fig. 10; tuning voltage is 15 V; band III at minimum gain.

Bandwidth variation of i.f. output circuit as a result of r.f. tuning and band switching (reference: v.h.f. III)

max. 350 kHz

Note: I.F. output of the tuner terminated with a modified circuit of Fig. 10, i.e. a 100 pF capacitor is connected in parallel with C1 and R1 is short-circuited; tuning voltage is 15 V.

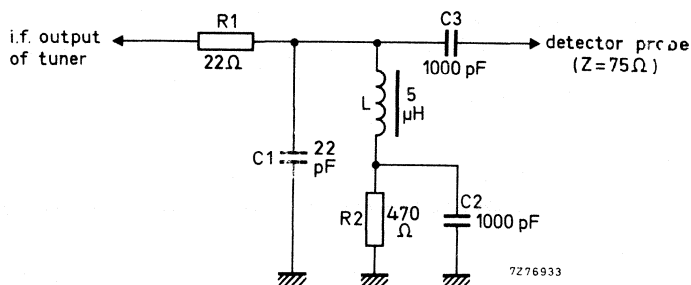

Fig. 10.

Detuning of the i.f. output circuit as a result of r.f. tuning and band switching (reference; v.h.f. III)

max. 350 kHz

Note: I.F. output of the tuner terminated with a modified circuit of Fig. 10, i.e. a 100 pF capacitor is connected in parallel with C1 and R1 is short-circuited; tuning voltage is 15 V.

Tuning range of i.f. output coil

max. 34 to min. 41 MHz

Note: I.F. output of the tuner terminated with the circuit shown in Fig. 10; tuning voltage is 15 V.

Attenuation between i.f. injection point and i.f. output of the tuner

typ. 23 dB

Miscellaneous

Radio interference

Oscillator radiation and oscillator voltage at the aerial terminal

Within the limits of C.I.S.P.R. 13 (1975) and VDE 0872/7.72.

For the oscillator radiation above 200 MHz use is made of the relaxed limit of 2 mV/m (66 dB μ V/m).

Microphonics

There will be no microphonics, provided the tuner is installed in a professional manner.

Surge protection

Protection against voltages

max. 8 kV

Note: Three discharges of a 470 pF capacitor into the aerial terminal.

Protection against flashes

max. 30 kV, 400 mWs

Note: A flashover circuit producing flashes with frequencies of 1 to 20 Hz for 30 s is connected to the aerial terminal.

ADDITIONAL INFORMATION

If the tuner is used in receivers designed for v.h.f. only, a capacitor of 8,2 pF should be applied between the aerial input and earth.

I.F. injection

The tuner is provided with an i.f. injection point at the collector of the mixer transistor (coupled via a capacitor and a resistor to terminal S). The i.f. generator can be connected directly to this point (Fig. 11).

The tuner needs normal supply voltages and a tuning voltage of 15 V; the i.f. output should be loaded with the circuit shown in Fig. 10.

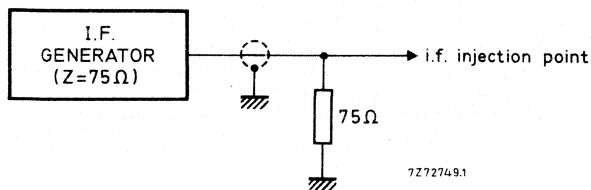

Fig. 11.

Connection of the i.f. amplifier

The tuner needs a d.c. path from the i.f. output terminal (T) to earth, preferably via a choke of approx. 5 μH outside the tuner (Fig. 12). Where the tuner is used in combination with a u.h.f. tuner, this choke can be common for both tuners; a resistor in series with the choke can make ineffective the i.f. output circuit of the switched off tuner. For damping the i.f. output circuit and matching the i.f. output impedance of the tuner to the i.f. amplifier, a series resistor and a parallel capacitor as shown in Fig. 12 should be used. (During v.h.f. operation the voltage across the 470 Ω resistor is 1 to 1,2 V.)

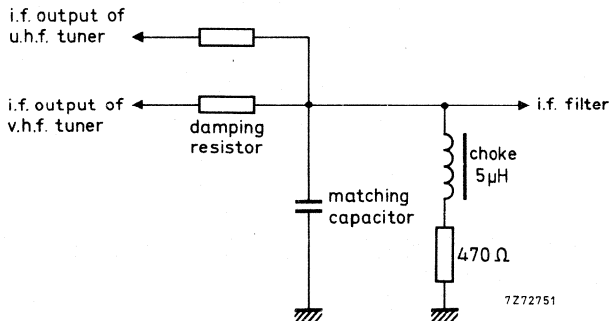

Fig. 12.

Measuring method of power gain

The i.f. output of the tuner should be terminated with the RC-circuit given in Fig. 10.

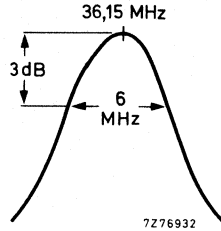

Fig. 13.

The RC-circuit roughly matches the i.f. output impedance to 75Ω at the resonant frequency of the i.f. output circuit, which should be tuned to 36,15 MHz; the bandwidth should be approx. 6 MHz (Fig. 13).

Because the input and output impedances of the tuner are now 75Ω , the power gain can be measured in the conventional manner by inserting tuner and RC-circuit between a 75Ω source and a 75Ω detector.

Alignment of the i.f. output coil

The i.f. output coil should be adjusted with a brass tool with a blade as shown in Fig. 14. A suitable tool is available under catalogue number 7122 005 47680.

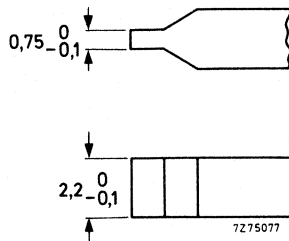

Fig. 14.

ACCESSORIES

Connector assembly for use of tuner V314 in combination with u.h.f. tuner U322:

connector, catalogue number 3112 200 20720;

washer, catalogue number 3112 221 01220;

clamp, catalogue number 3112 274 13220.

V.H.F. TELEVISION TUNERS

QUICK REFERENCE DATA

Systems	C.C.I.R. systems B and G
Channels	
v.h.f. I	E2 to S1
v.h.f. III	S2 to min. S17 (typ. S19)
Intermediate frequencies	
picture	38,9 MHz
sound	33,4 MHz

APPLICATION

These tuners are designed to cover the v.h.f. channels of C.C.I.R. systems B and G, including the S channels for cable television.

In combination with the u.h.f. tuner U322 they can be used in v.h.f./u.h.f. receivers. The aerial inputs and i.f. outputs of both tuners can then be connected in parallel without additional circuitry.

The tuners are compatible with tuner V314. They are also compatible with tuner V311, except for the band switching.

The V315LO is a special version of the V315: an output voltage from the local oscillator is made available for driving digital tuning systems. Apart from this the tuners are identical.



DESCRIPTION

The tuners are v.h.f. tuners with electronic tuning, covering the v.h.f. band I (47 to 111 MHz) and the v.h.f. band III (111 to 279 MHz). Switching between the bands is done by external band switching.

Mechanically, the tuners are built on a printed-wiring board, carrying all components, in a metal housing made of a rectangular frame and front and rear cover (see Fig. 2a). All connections (aerial, supply voltage, a.g.c. voltage, tuning voltage, i.f. injection, i.f. output) are made via terminals on the underside. The mounting method is shown in Fig. 3. Tuner V315LO has a coaxial socket on the top of the frame, for coupling out the oscillator sample.

Electrically the tuner consists of two tunable input circuits in parallel (bands I and III), each followed by an r.f. transistor in grounded-base configuration (BF939 for band I, BF967 for band III). The collector load of each input transistor is formed by a double tuned circuit, transferring the signal to the mixer BF324 fed by the oscillator BF198. Eight capacitance diodes BB209 tune the double-tuned circuit and the oscillator.

The i.f. output circuit of the tuner is a single tuned one, at the low end of which the i.f. signal is coupled out of the tuner. A d.c. path to earth for the collector current of the mixer has to be provided outside the tuner, preferably by a choke of about $5 \mu\text{H}$. Damping of the i.f. output circuit and matching of the i.f. output to the i.f. circuit of the receiver can be achieved by connecting a series resistance and a parallel capacitance outside the tuner.

An i.f. injection point has been provided at the collector of the mixer transistor, connected to terminal S.



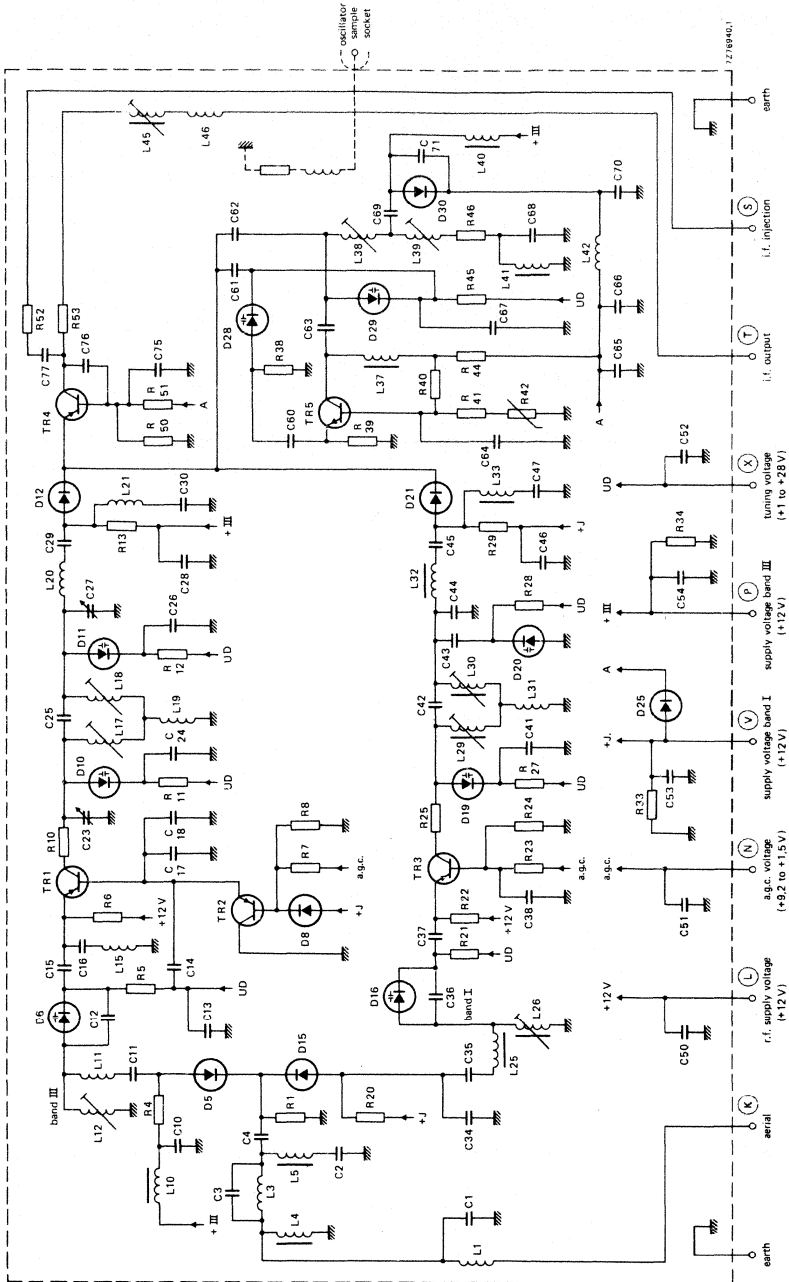

Fig. 1.



MECHANICAL DATA

Dimensions in mm

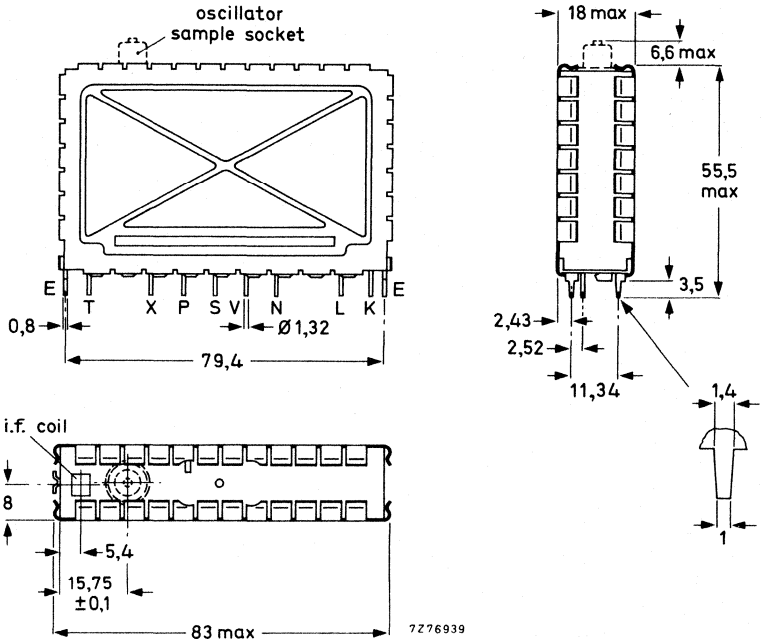

Fig. 2a The oscillator sampling socket, drawn with dotted lines, applies only to tuner V315LO.

- Terminal T = i.f. output
 X = tuning voltage, + 1 to + 28 V
 P = supply voltage, band III, + 12 V
 S = i.f. injection point
 V = supply voltage, band I, + 12 V
 N = a.g.c. voltage, + 9,2 to 1,5 V
 L = r.f. stage supply voltage, + 12 V
 K = aerial

Note: When the tuner is operated together with a u.h.f. tuner, only the supply voltage at terminals P and V should be switched off during u.h.f. operation.

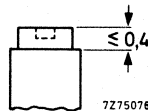

Fig. 2b I.F. output coil.
 Torque for alignment: 2 to 15 mNm
 Press-through force: ≥ 10 N

Mass

approx. 80 g

Mounting

The tuner may be mounted by soldering it on to a printed-wiring board, using the piercing diagram shown in Fig. 3. (The tuner may also be mounted by means of a socket. Information will be supplied upon request.)

It is recommended that the tuner be installed in the cool part of the receiver cabinet and not exposed to the vibrations of the loudspeaker. There are no restrictions on orientation.

The solderability of the terminals and mounting tabs is according to IEC 68-2, test Ta ($230 \pm 10^\circ\text{C}$, $2 \pm 0,5$ s). The resistance to soldering heat is according to IEC 68-2, test Tb ($260 \pm 5^\circ\text{C}$, 10 ± 1 s).

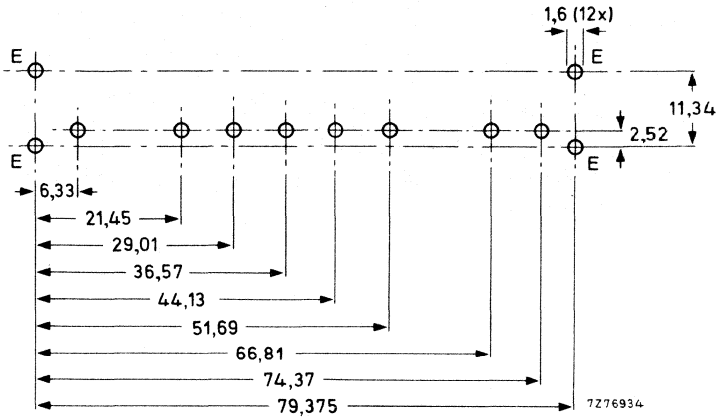

Fig. 3 Piercing diagram viewed from solder side of board.

For connection to the socket on the top of tuner V315LO a coaxial plug has to be used; type 3/2-50 (manufacturer: Daut und Rietz) is recommended.

ELECTRICAL DATA

The electrical values are measured on the v.h.f. tuner alone, but they are also valid for the v.h.f. tuner in combination with a u.h.f. tuner U322. Unless otherwise specified all electrical values apply at an ambient temperature of 25 ± 5 °C, a relative humidity of $60 \pm 15\%$, a supply voltage of $12 \pm 0,3$ V and an a.g.c. voltage of $9,2 \pm 0,2$ V.

Within the given tolerance range of supply voltage and a.g.c. voltage only insignificant deviations from the specified values can be expected. Under the extreme conditions of temperature and humidity as given below, the tuner will function normally, but some specified limits may be exceeded.

General

Semiconductors

r.f. amplifier, band I	BF939
r.f. amplifier, band III	BF967
mixer	BF324
oscillator	BF198
tuning diodes	8 x BB209
switching diodes	BA182; 3 x BA244; MPM3401; 3 x BAF10
switching transistor	BC558

Ambient temperature range

operating	+ 5 to + 55 °C
storage	-25 to + 85 °C

Relative humidity

max. 90%

Voltages and currents

Supply voltage

+ 12 V \pm 10%

Note: The supply voltage at terminals P and V should be filtered.

Current drawn from + 12 V supply

r.f. amplifier, v.h.f. I, at nominal gain	typ. 5,0 mA
v.h.f. I, at 40 dB gain reduction	typ. 12,0 mA
r.f. amplifier, v.h.f. III, at nominal gain	typ. 9 mA
v.h.f. III, at 40 dB gain reduction	typ. 20 mA
mixer and oscillator	typ. 12 mA

Band switching

For operation in band I the supply voltage must be connected to terminal V, for band III operation to terminal P. If the tuner operates together with a u.h.f. tuner only the supply voltage at terminals P and V should be switched off during u.h.f. operation.

A.G.C. voltage (Figs 4 to 7)

at nominal gain

$+9,2 \pm 0,5$ V

at 40 dB gain reduction

min. $+1,5$ V

Note: A.G.C. voltages between 0 and $+10$ V may be applied without risk of damage.

A.G.C. current

during gain control (0 to 40 dB)

max. $+0,5$ mA

min. $-2,4$ mA

at nominal gain

typ. $+0,3$ mA

at 40 dB gain reduction

typ. $-1,2$ mA

Tuning voltage range (Figs 8 and 9)

$+1$ to $+28$ V

Current drawn from $+28$ V tuning voltage supply

at 25 °C

max. 400 nA

at 55 °C

max. 4 μ A

Note: The source impedance of the tuning voltage offered to terminal X must be max. 47 k Ω .

Switching current

max. 16 mA

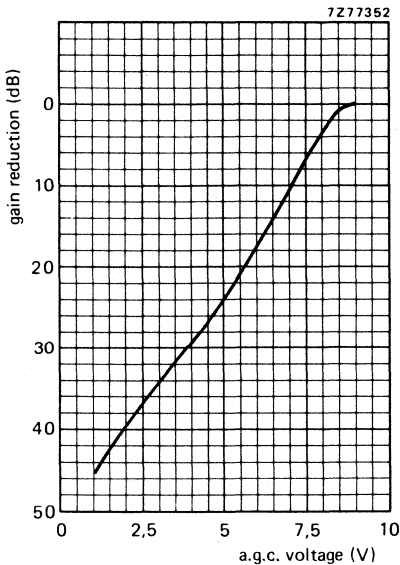

Fig. 4 A.G.C. voltage characteristic, channel E2; typical curve.

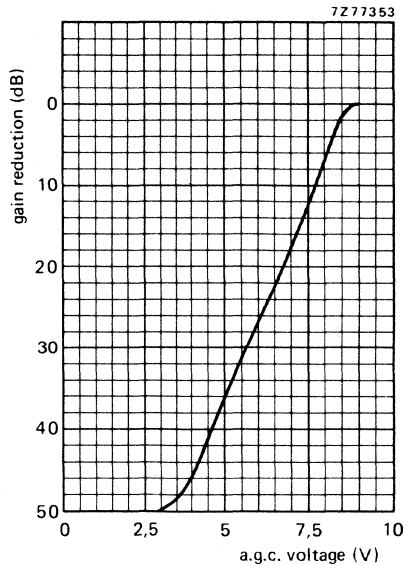

Fig. 5 A.G.C. voltage characteristic, channel S1; typical curve.

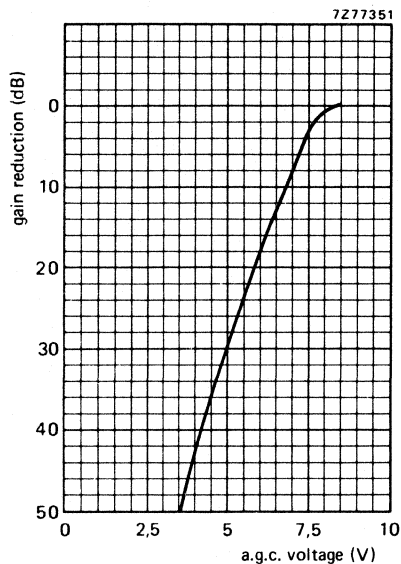

Fig. 6 A.G.C. voltage characteristic, channel S2; typical curve.

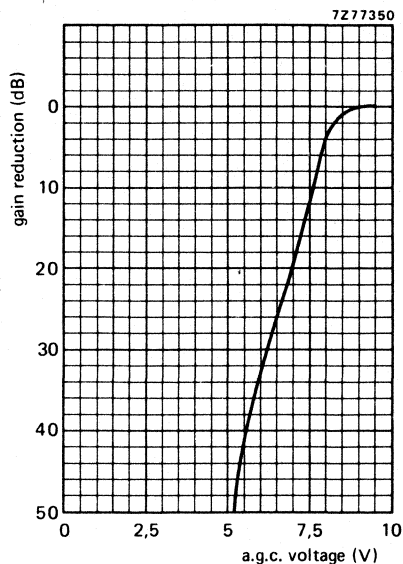

Fig. 7 A.G.C. voltage characteristic, channel S20; typical curve.

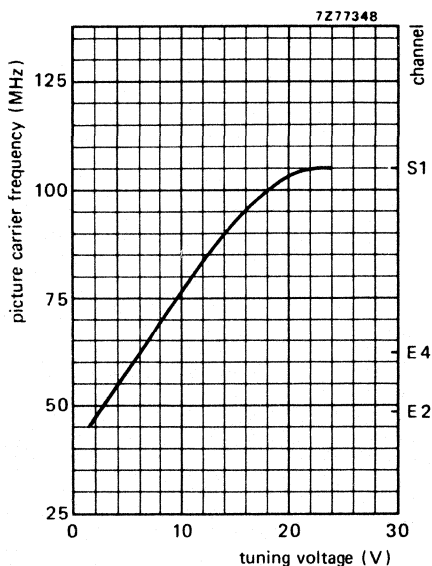

Fig. 8 Tuning voltage characteristic, v.h.f. I; typical curve.

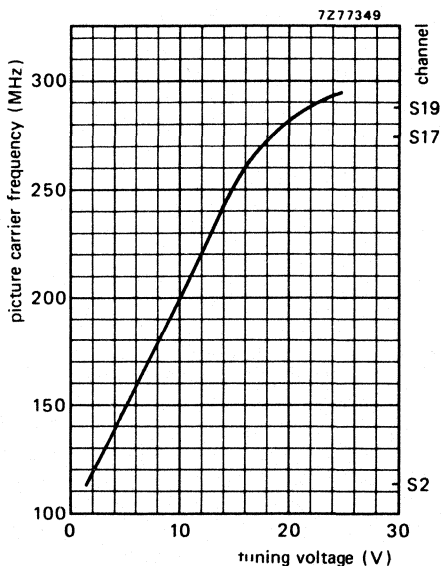

Fig. 9 Tuning voltage characteristic, v.h.f. III; typical curve.

Oscillator sample signal; **only valid for V315LO**

at + 12 V supply voltage and
 $T_{amb} = + 25^{\circ}C$
 within the given tolerance range of
 supply voltage and given operating-
 temperature range, and **within** the
 tuning voltage range + 0,5 to + 30 V

typ. 84 dB (μV) into 75 Ω

min. 80 dB (μV) into 75 Ω
 max. 100 dB (μV) into 75 Ω

Note: A tuning voltage higher than + 28 V will not be harmful for the tuner and may be applied at the user's own risk. Under this condition the published reverse voltage limit of the oscillator tuning diode will be exceeded; the oscillator frequency will never decrease with increasing tuning voltage.

Frequency of oscillator sample signal; **only valid for V315LO**

v.h.f. I 87,15 to 144,15 MHz
 v.h.f. III 151,15 to 312,15 MHz (typ. 326,15 MHz)

Frequencies

Frequency ranges

v.h.f. I channel E2 (picture carrier 48,25 MHz)
 to channel S1 (picture carrier 105,25 MHz)
 Margin at the extreme channels: min. 1 MHz

v.h.f. III channel S2 (picture carrier 112,25 MHz)
 to channel S17 (picture carrier 273,25 MHz)
 Margin at the extreme channels: min. 1 MHz

Intermediate frequencies

picture 38,9 MHz
 sound 33,4 MHz
 The oscillator frequency is higher than the
 aerial signal frequency.

Wanted signal characteristics

Input impedance

asymmetrical 75 Ω

Input impedance of oscillator sample socket; **only valid for V315LO**

asymmetrical 75 Ω

V.S.W.R. and reflection coefficient

	minimum value between picture carrier and sound carrier frequency	maximum value at picture carrier frequency
v.s.w.r.	max. 4	max. 4
reflection coefficient	max. 60%	max. 60%

V.S.W.R. and reflection coefficient at oscillator sample socket; **only valid for V315LO**

v.s.w.r., v.h.f. I	max. 2
v.s.w.r., v.h.f. III	max. 2
reflection coefficient, v.h.f. I	max. 33%
reflection coefficient, v.h.f. III	max. 33%



R.F. curves, bandwidth	typ. 12 MHz
R.F. curves, tilt	on any channel the amplitude difference between the top of the r.f. resonant curve and the picture carrier marker, the sound carrier marker, or any frequency between them will not exceed 3 dB at nominal gain, and 4 dB in the a.g.c. range between nominal gain and 20 dB gain reduction.
A.G.C. range, except channels E2 and E3	min. 40 dB
A.G.C. range, channels E2 and E3	min. 30 dB
Power gain (see also Measuring method of power gain)	min. 22 dB
channel E3	typ. 29 dB
channel E5	typ. 25 dB
channel E12	typ. 29 dB
Gain difference between any two channels	typ. 6 dB
Noise figure	max. 10 dB
channel E3	typ. 7 dB
channel E5	typ. 8,5 dB
channel E12	typ. 8 dB

Unwanted signal characteristics

Image rejection (measured at picture carrier frequency), channels E2 to E12	min. 60 dB
I.F. rejection (measured at picture carrier frequency), channel E2	min. 55 dB

Note: At colour sub-carrier frequency max. 6 dB less rejection.

Harmonic content of oscillator sample; **only valid for V315LO**

Suppression of harmonics which fall into the frequency range below 1000 MHz min. 15 dB below oscillator fundamental

R.F. rejection at oscillator sample socket; **only valid for V315LO**

Signal voltage at oscillator sample socket (input signals of wanted frequency 70 dB (μ V) into 75 Ω , tuner operating at nominal gain) min. 20 dB below oscillator fundamental

I.F. rejection at oscillator sample socket; **only valid for V315LO**

I.F. signals at oscillator sample socket (input signals of wanted frequency 70 dB (μ V) into 75 Ω , tuner operating at nominal gain) min. 20 dB below oscillator fundamental



Oscillator characteristics**Pulling**

Input signal of tuned frequency producing
a shift of the oscillator frequency of
10 kHz, at nominal gain

v.h.f. I

typ. 75 dB (μ V) into 75 Ω

v.h.f. III

typ. 75 dB (μ V) into 75 Ω

Shift of oscillator frequency

at a change of the supply voltage of 5%

max. 400 kHz

Drift of oscillator frequency

during warm-up time (after the tuner
has been completely out of operation
for 15 min, measured between 5 s
and 15 min after switching on)

max. 250 kHz

during warm-up time (after the input
stage is in operation for 15 min,
measured between 2 s and 15 min
after switching on the self-oscillating
mixer stage)

max. 250 kHz

at a change of the ambient temperature
from + 25 to + 40 °C (measured after
3 cycles from + 25 to + 60 °C)

max. 650 kHz

I.F. circuit characteristics

Bandwidth of i.f. output circuit

6 MHz

Note: I.F. output of the tuner terminated with the circuit shown in Fig. 10; tuning voltage is 15 V;
band III at minimum gain.

Bandwidth variation of i.f. output circuit
as a result of r.f. tuning and
band switching (reference: v.h.f. III)

max. 350 kHz

Note: I.F. output of the tuner terminated with a modified circuit of Fig. 10, i.e. a 100 pF capacitor of
connected in parallel with C1 and R1 is short-circuited; tuning voltage is 15 V.



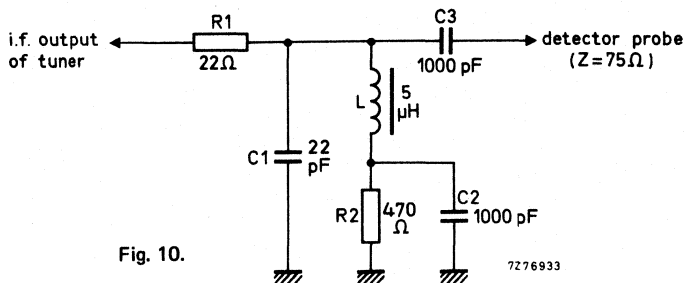

Fig. 10.

7276933

Detuning of the i.f. output circuit as a result of r.f. tuning in band III

max. 350 kHz

Note: I.F. output of the tuner terminated with a modified of Fig. 10, i.e. a 100 pF capacitor is connected in parallel with C1 and R1 is short-circuited; tuning voltage is 15 V.

Tuning range of i.f. output coil

max. 34 to min. 41 MHz

Note: I.F. output of the tuner terminated with the circuit shown in Fig. 10; tuning voltage is 15 V.

Attenuation between i.f. injection point and i.f. output of the tuner

typ. 23 dB

Miscellaneous

Radio interference
Oscillator radiation and oscillator voltage at the aerial terminal

Within the limits of C.I.S.P.R. 13 (1975) and VDE 0872/7.72.*

For the oscillator radiation above 200 MHz use is made of the relaxed limit of 2 mV/m (66 dBμV/m).

Microphonics

There will be no microphonics, provided the tuner is installed in a professional manner.

Surge protection

Protection against voltages

max. 8 kV

Note: Three discharges of a 470 pF capacitor into the aerial terminal.

Protection against flashes

max. 30 kV, 400 mWs

Note: A flashover circuit producing flashes with frequencies of 1 to 20 Hz for 30 s is connected to the aerial terminal.

* For V315LO: when the oscillator sample socket is either open or terminated with a shielded resistor of 75 Ω.

ADDITIONAL INFORMATION

I.F. injection

The tuner is provided with an i.f. injection point at the collector of the mixer transistor (coupled via a capacitor and a resistor to terminal S). The i.f. generator can be connected directly to this point (Fig. 11).

The tuner needs normal supply voltages and a tuning voltage of 15 V; the i.f. output should be loaded with the circuit shown in Fig. 10.

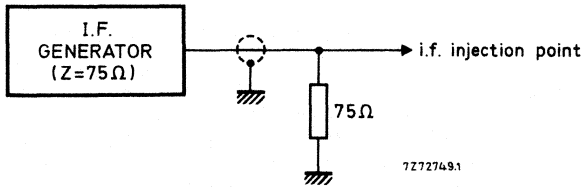

Fig. 11.

Connection of the i.f. amplifier

The tuner needs a d.c. path from the i.f. output terminal (T) to earth, preferably via a choke of approx. $5 \mu\text{H}$ outside the tuner (Fig. 12). Where the tuner is used in combination with a u.h.f. tuner, this choke can be common for both tuners; a resistor in series with the choke can make ineffective the i.f. output circuit of the switched-off tuner. For damping the i.f. output circuit and matching the i.f. output impedance of the tuner to the i.f. amplifier, a series resistor and a parallel capacitor as shown in Fig. 12 should be used (During v.h.f. operation the voltage across the 470Ω resistor is 1 to 1,2 V.)

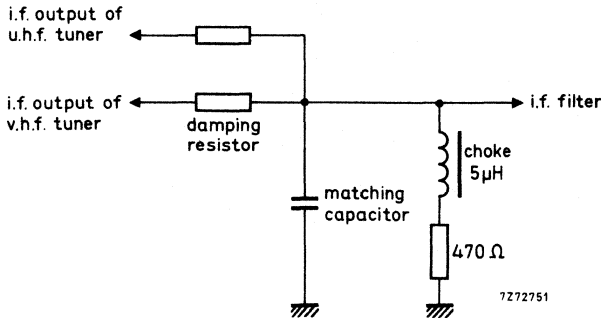

Fig. 12.



Measuring method of power gain

The i.f. output of the tuner should be terminated with the RC-circuit given in Fig. 10.

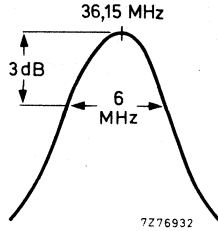

Fig. 13.

The RC-circuit roughly matches the i.f. output impedance to 75Ω at the resonant frequency of the i.f. output circuit, which should be tuned to 36,15 MHz; the bandwidth should be approx. 6 MHz (Fig. 13). Because the input and output impedances of the tuner are now 75Ω , the power gain can be measured in the conventional manner by inserting tuner and RC-circuit between a 75Ω source and a 75Ω detector.

Alignment of the i.f. output coil

The i.f. output coil should be adjusted with a brass tool with a blade as shown in Fig. 14. A suitable tool is available under catalogue number 7122 005 47680.

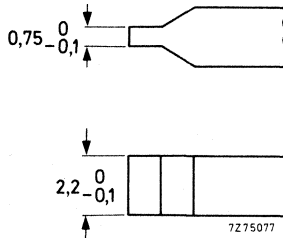

Fig. 14.

ACCESSORIES

- Connector assembly for use of tuner V315 or V315LO in combination with u.h.f. tuner U322 (or UDI):
- connector, catalogue number 3112 200 20720;
- washer, catalogue number 3112 221 01220;
- clamp, catalogue number 3112 274 13220.

COAXIAL AERIAL INPUT ASSEMBLIES

APPLICATION

These coaxial aerial input assemblies have been developed for application in television sets with 75 ohm input impedance, for use in v.h.f. as well as in u.h.f. (40-890 MHz). The connectors meet the demands of both the IEC standards (diameter 9,5 mm) and the French standards (diameter 9,0 mm). They have to be used with plugs complying with the properties mentioned in DIN 45325, IEC 169-2 (diameter 9,5 mm) and SNIR (diameter 9,0 mm). The units meet the safety requirements of IEC 65.

AVAILABLE TYPES

Coaxial aerial input assembly 75 Ω

- Attenuation : ≤ 1 dB
 Reflection, v.h.f. : $\leq 15\%$
 u.h.f. : $\leq 25\%$
 Catalogue number : 3122 127 10260

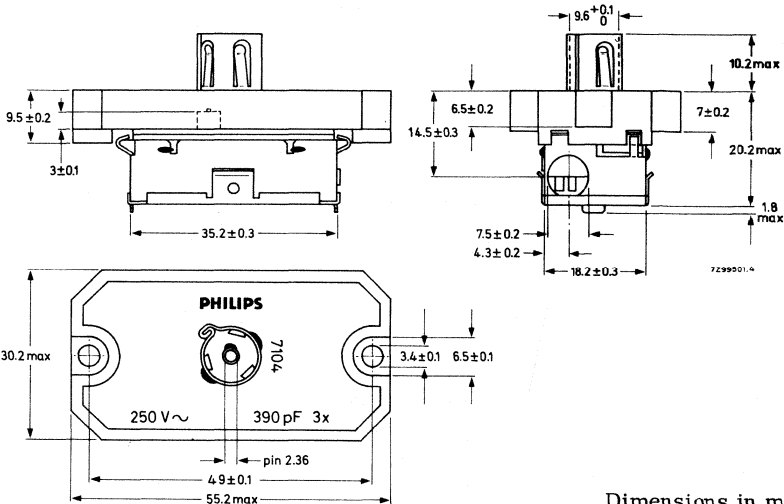
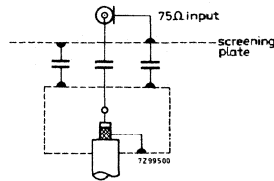

Dimensions in mm

3122 127 10260
 3122 127 10450
 3122 127 14730

COAXIAL AERIAL INPUT ASSEMBLIES

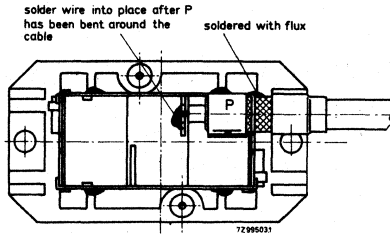

Recommended fixing of the aerial cable
 Soldering conditions : $370 \pm 5 \text{ }^\circ\text{C}$; $3,5 \pm 0,5 \text{ s}$

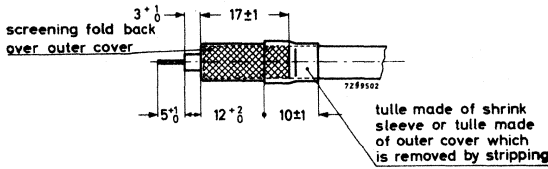

Cable diameter $\geq 5 \text{ mm}$

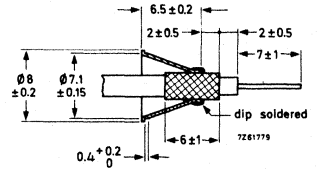

Cable diameter $< 5 \text{ mm}$

Coaxial aerial input assembly 75 Ω, with filter

Reflection, v. h. f.	≤ 25%
u. h. f.	≤ 30%
Frequency characteristic	
v. h. f. , 50 to 230 MHz	≤ 1 dB
470 MHz	≥ 13 dB
700 MHz	23 dB (typical value)
u. h. f. , 470 to 850 MHz	≤ 1 dB
230 MHz	≥ 15 dB
100 MHz	40 dB (typical value)
Catalogue number	3122 127 10450

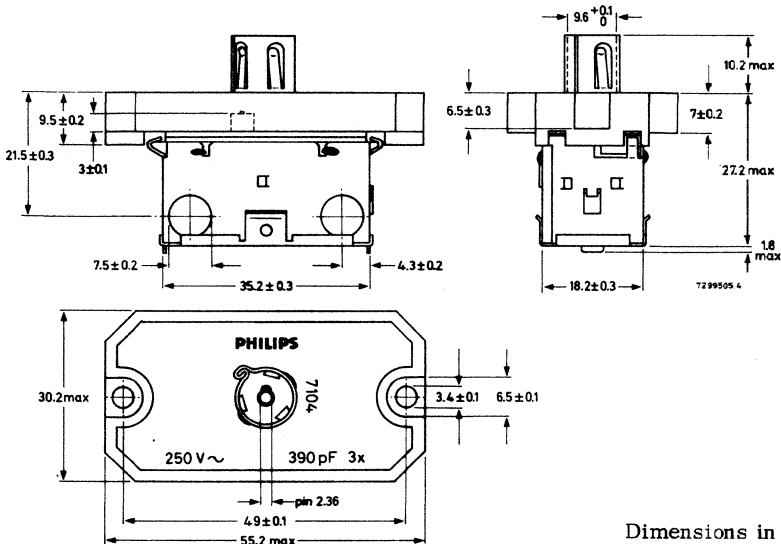
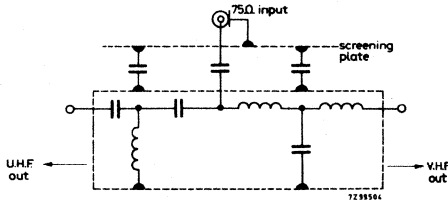

Dimensions in mm

3122 127 10260
 3122 127 10450
 3122 127 14730

COAXIAL AERIAL INPUT ASSEMBLIES

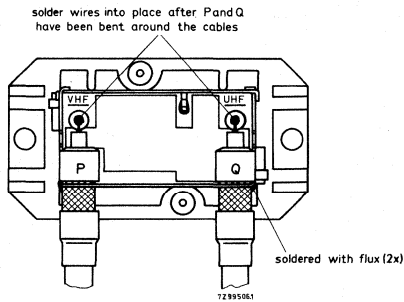

Recommended fixing of the aerial cable
 Soldering conditions: $370 \pm 5 \text{ }^\circ\text{C}$; $3,5 \pm 0,5 \text{ s}$

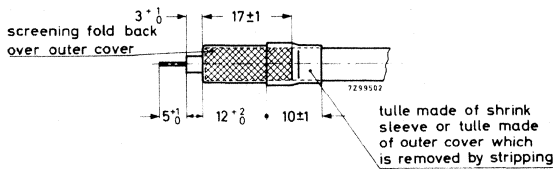

Cable diameter $\geq 5 \text{ mm}$

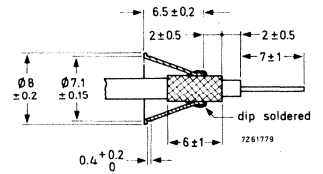

Cable diameter $< 5 \text{ mm}$

Coaxial aerial input assembly 75 Ω, with high-pass filter

Attenuation at 1 MHz : 60 dB (typical value)
 5 MHz : 40 dB (typical value)
 10 MHz : ≥ 25 dB
 50 MHz : ≤ 1 dB
 230 MHz : ≤ 1 dB
 470 MHz : ≤ 1 dB
 850 MHz : $\leq 1,5$ dB

Reflection, v. h. f. I : $\leq 35\%$
 v. h. f. III : $\leq 15\%$
 u. h. f. : $\leq 35\%$

Catalogue number : 3122 127 14730

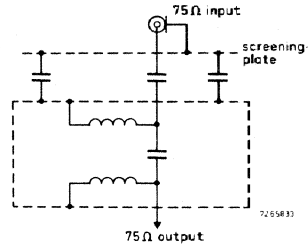

Dimensions in mm

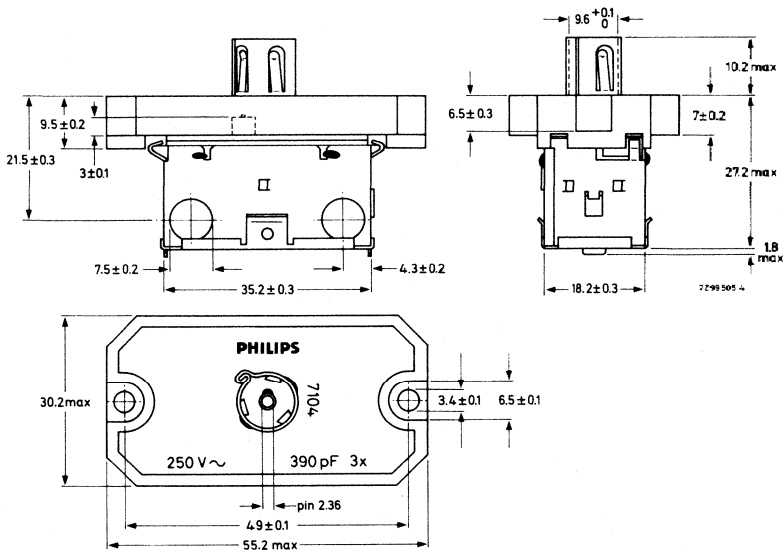

3122 127 10260
 3122 127 10450
 3122 127 14730

COAXIAL AERIAL INPUT ASSEMBLIES

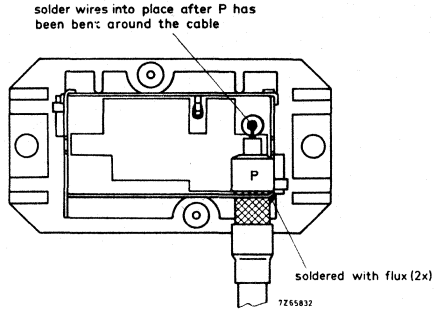

Recommended fixing of the aerial cable
 Soldering conditions : 370 ± 5 °C; $3,5 \pm 0,5$ s

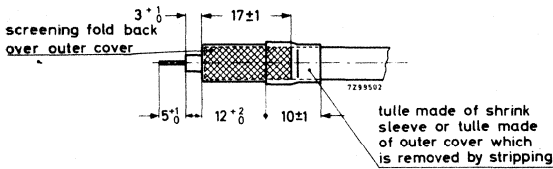

Cable diameter ≥ 5 mm

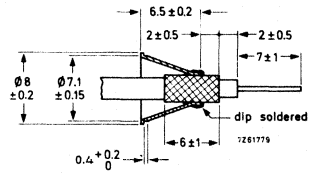

Cable diameter < 5 mm

Surface acoustic wave filters



SURFACE ACOUSTIC WAVE FILTER

The SW102/M is a lithium niobate surface wave device for use as an i.f. bandpass filter in colour and monochrome TV receivers. It is specifically designed for CCIR system I as used in the United Kingdom. Its use in place of conventional LC circuitry improves the amplitude and group delay characteristics as well as avoiding the need for critical adjustments in receiver production. The response characteristics are stable with life.

QUICK REFERENCE DATA

	Frequency MHz		Amplitude dB
Vision carrier	39.5		-6
Sound carrier	33.5	typ.	-21
Adjacent vision trap	31.5	<	-40
Adjacent sound trap	41.5	<	-46
Insertion loss (300 Ω source and load)	37.0	typ.	17
Operating temperature range	-10 to +70 °C		

MECHANICAL DATA

Dimensions in mm

5 lead TO-8

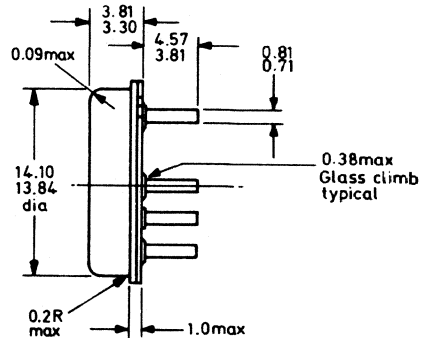
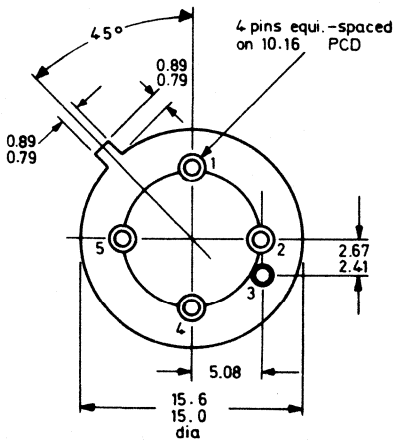

D8153

- Connections
1. balanced output
 2. input high
 3. can (earth)
 4. input (earth)
 5. balanced output

RATINGS

Limiting values in accordance with the Absolute Maximum System (IEC134)

Operating ambient temperature	- 10 to + 70 °C
Storage temperature	- 25 to + 85 °C
Pin to pin voltage (short term) max. *	30 V

CHARACTERISTICS

Test conditions**

Ambient temperature	25 °C
Input drive impedance	50 Ω
Load impedance (balanced)	300 Ω

Amplitude response

	Frequency	Amplitude		
	MHz	dB		
Vision carrier (reference level)	39.5	-6		
		min.	typ.	max.
Chroma carrier	35.07	-6	-1.5	
Sound carrier	33.5	-23	-21	-19
Adjacent vision trap	31.5			-40
Adjacent sound trap	41.5		-50	-46
In-band ripple (p-p)	36 to 38		0.5	1.0
Out of band response	0 to 60			-38
Out of band response	60 to 150			-20

* For maximum operating life, the filter should be used with d.c. isolating capacitors.

** The amplitude level at the vision carrier frequency is -6 dB and is used as the reference for all relevant measurements.

General

	Frequency MHz		
Insertion loss (300 Ω source and load)	36 to 38	typ.	17 dB
Voltage attenuation ratio (in preferred application circuit with a 50 Ω source and 300 Ω load)	37	typ.	22 dB
Group delay (relative to 0 ns at 39.5 MHz)	34.5 to 40.5	min.	-40 ns
		max.	+40 ns
Spurious reflections and direct breakthrough (measured using 2Tsin ² pulse and bar)	39.5	max.	-40 dB
2Tsin ² pulse and bar k rating		max.	3.0 %
Temperature coefficient of frequency		typ.	-90 ppm/°C
Small signal impedance			
input	37.0	typ.	1.7 k Ω //16.8 pF
output	37.0	typ.	1.7 k Ω //6.2 pF



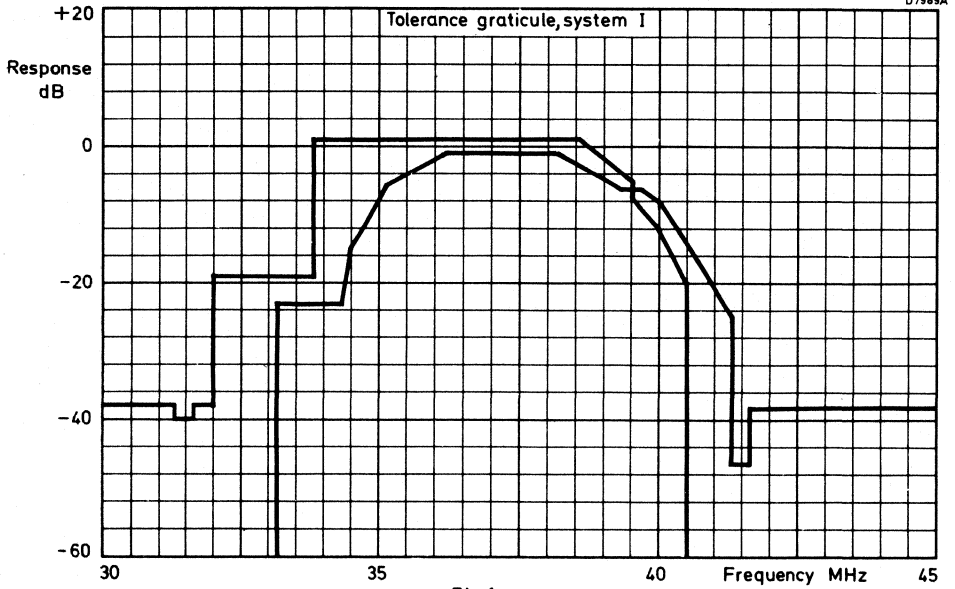

Fig.1

Test and basic application circuit

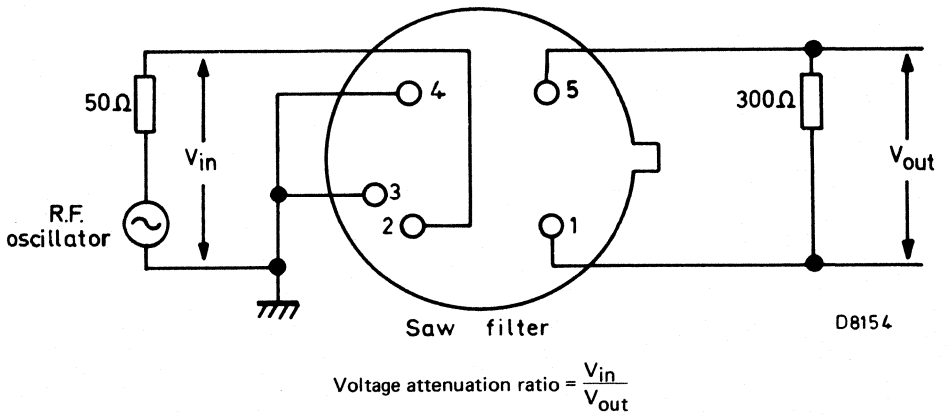
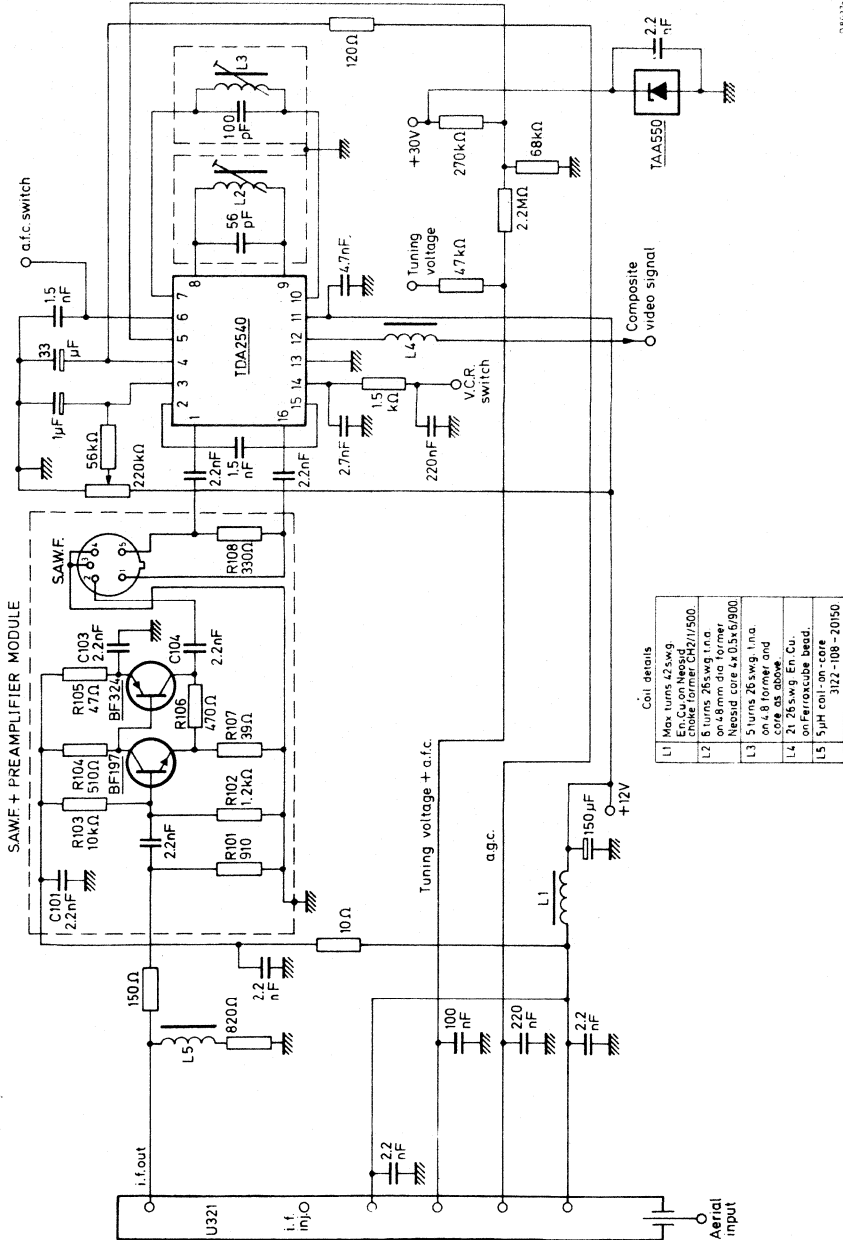

Fig.2



08/71a

Fig.3

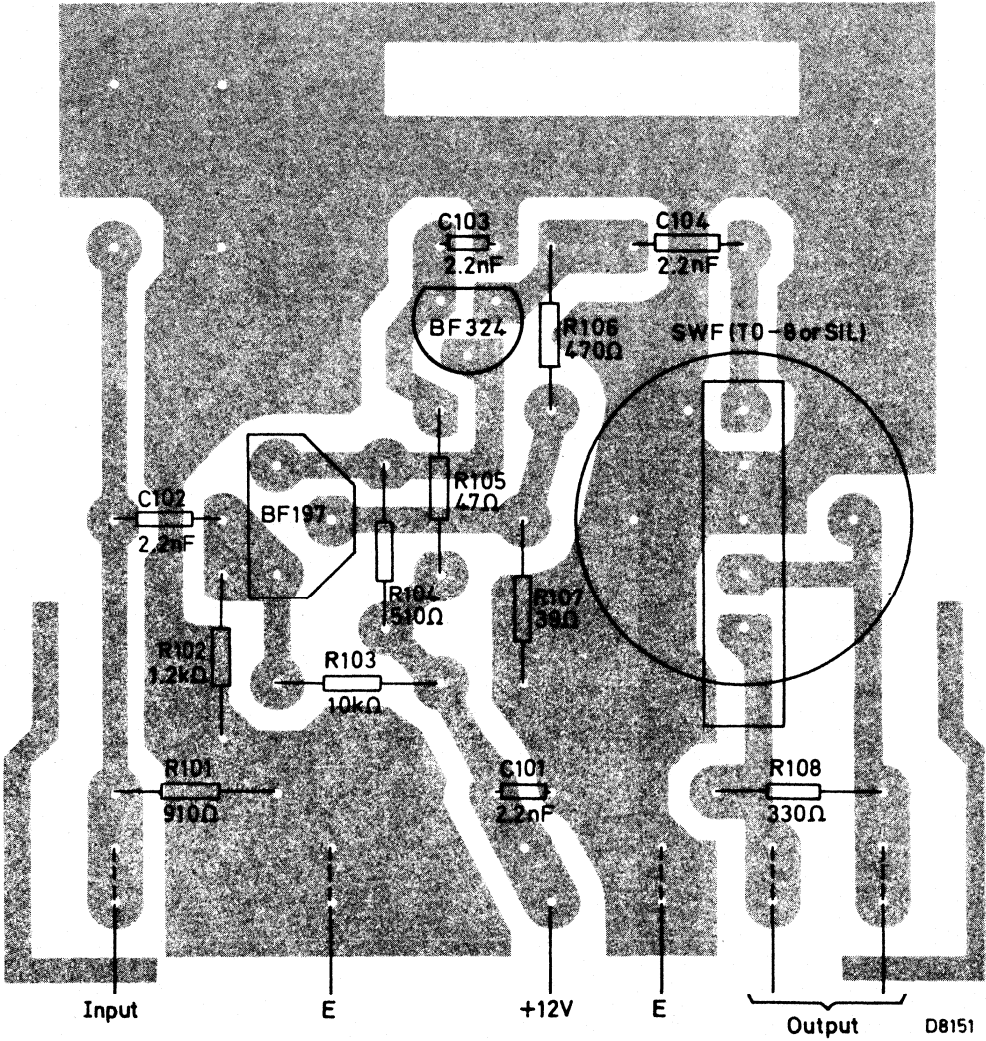

Fig.4 Recommended printed circuit board layout for surface acoustic wave filter and pre-amplifier

SURFACE ACOUSTIC WAVE FILTER

The SW211/M is a lithium niobate surface wave device for use as an i.f. bandpass filter in colour and monochrome TV receivers. It is specifically designed for CCIR systems B and G as used in European and other countries. Its use in place of conventional LC circuitry improves the amplitude and group delay characteristics as well as avoiding the need for critical adjustments in receiver production. The response characteristics are stable with life.

QUICK REFERENCE DATA

	Frequency MHz		Amplitude dB
Vision carrier	38.9		-6
Sound carrier	33.4	typ.	-24
Adjacent vision trap	31.9	<	-40
Adjacent sound trap	system B	<	-46
	system G	<	-40
Insertion loss (300 Ω source and load)	37.0	typ.	17
Operating temperature range	-10 to +70 °C		

MECHANICAL DATA

Dimensions in mm

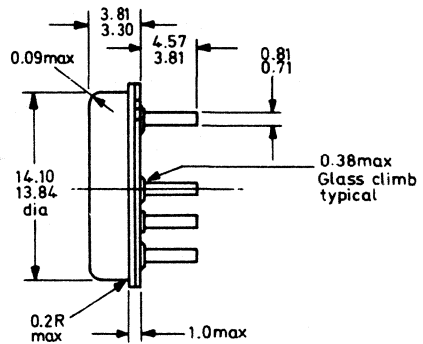
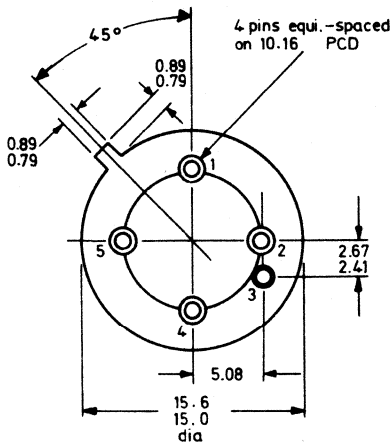

D8153

- Connections
1. balanced output
 2. input high
 3. can earth
 4. input earth
 5. balanced output

RATINGS

Limiting values in accordance with the Absolute Maximum System (IEC134)

Operating ambient temperature	- 10 to + 70 °C
Storage temperature	- 25 to + 85 °C
Pin to pin voltage (short term) max. (note 1)	30 V

CHARACTERISTICS

Test conditions (note 2)

Ambient temperature	25 °C
Input drive impedance	50 Ω
Load impedance (balanced)	300 Ω

Amplitude response

	Frequency MHz	Amplitude dB		
		min.	typ.	max.
Vision carrier (reference level)	38.9	-6		
Chroma carrier	34.47	-6	-4	
Sound carrier	33.4	-27	-25	-20
Adjacent vision trap	31.9			-40
Adjacent sound trap	system B (note 3)		-50	-46
	system G (note 4)		-45	-40
In-band ripple (p-p)	36 to 38	0.5	1.0	
Out of band response	0 to 60			-38
Out of band response	60 to 150			-20

Notes

1. For maximum operating life, the filter should be used with d.c. isolating capacitors.
2. The amplitude level at the vision carrier frequency is -6 dB and is used as the reference for all relevant measurements.
3. 7 MHz channel spacing.
4. 8 MHz channel spacing.

General

	Frequency MHz		
Insertion loss (300 Ω source and load)	36 to 38	typ.	17 dB
Voltage attenuation ratio (in preferred application circuit with 50 Ω source and 300 Ω load)	37	typ.	22 dB
Group delay (relative to 0 ns at 38.9 MHz)	34.1 to 39.65	see fig.2	
Spurious reflections and direct breakthrough (measured using 2Tsin ² pulse and bar)	38.9	max.	-40 dB
2Tsin ² pulse and bar k rating			3.0 %
Temperature coefficient of frequency		typ.	-90 ppm/°C
Small signal impedance			
input	37.0		1.3 kΩ//22 pF
output	37.0		1.4 kΩ//6.7 pF

Test and basic application circuit

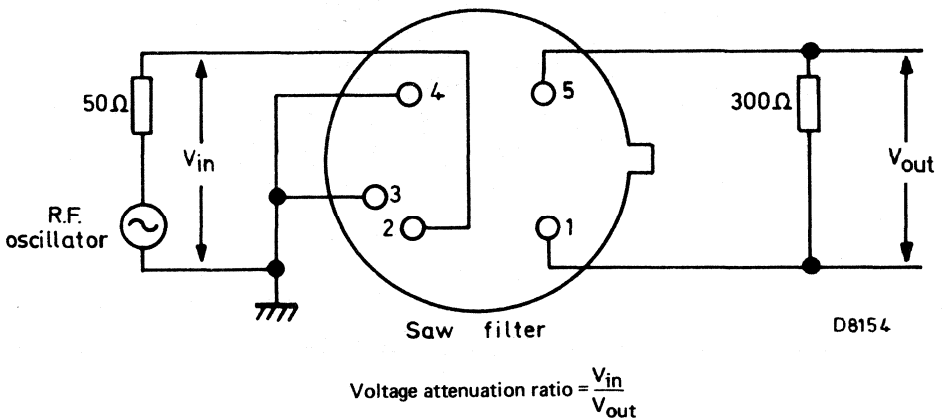

Fig.1

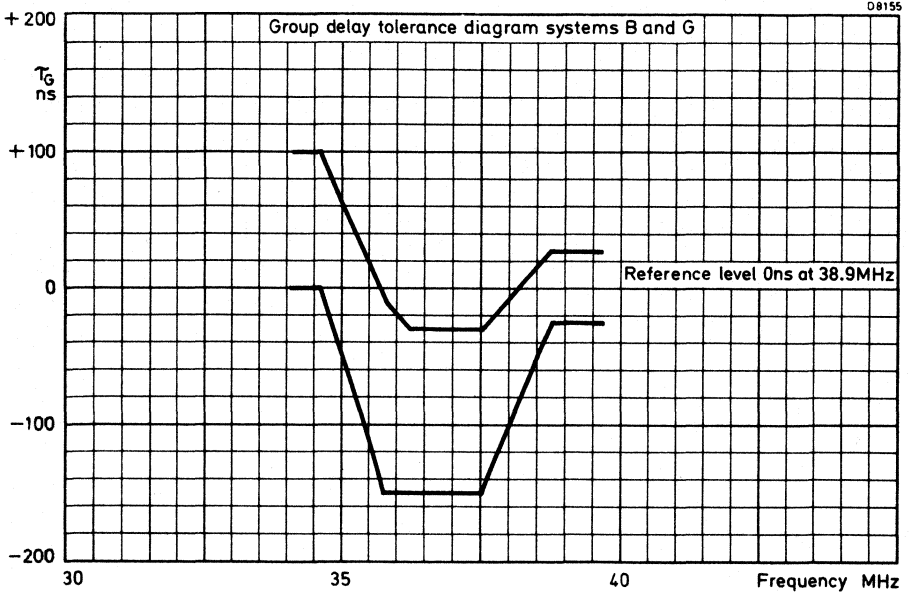

Fig.2

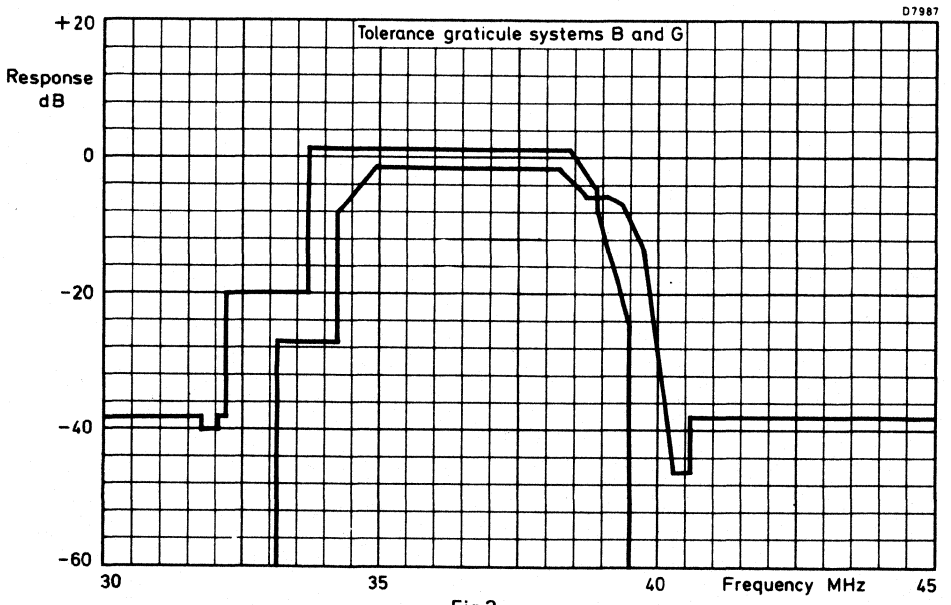

Fig.3

040184

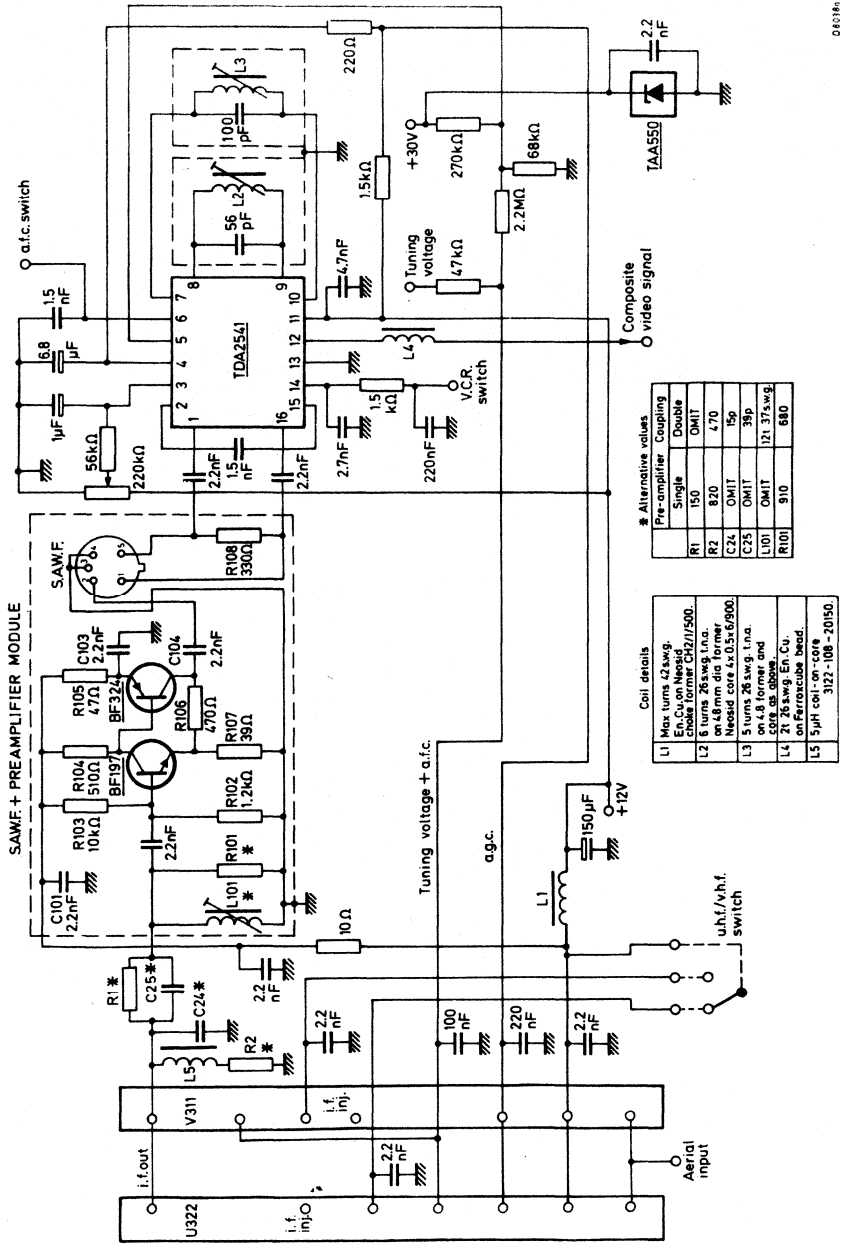
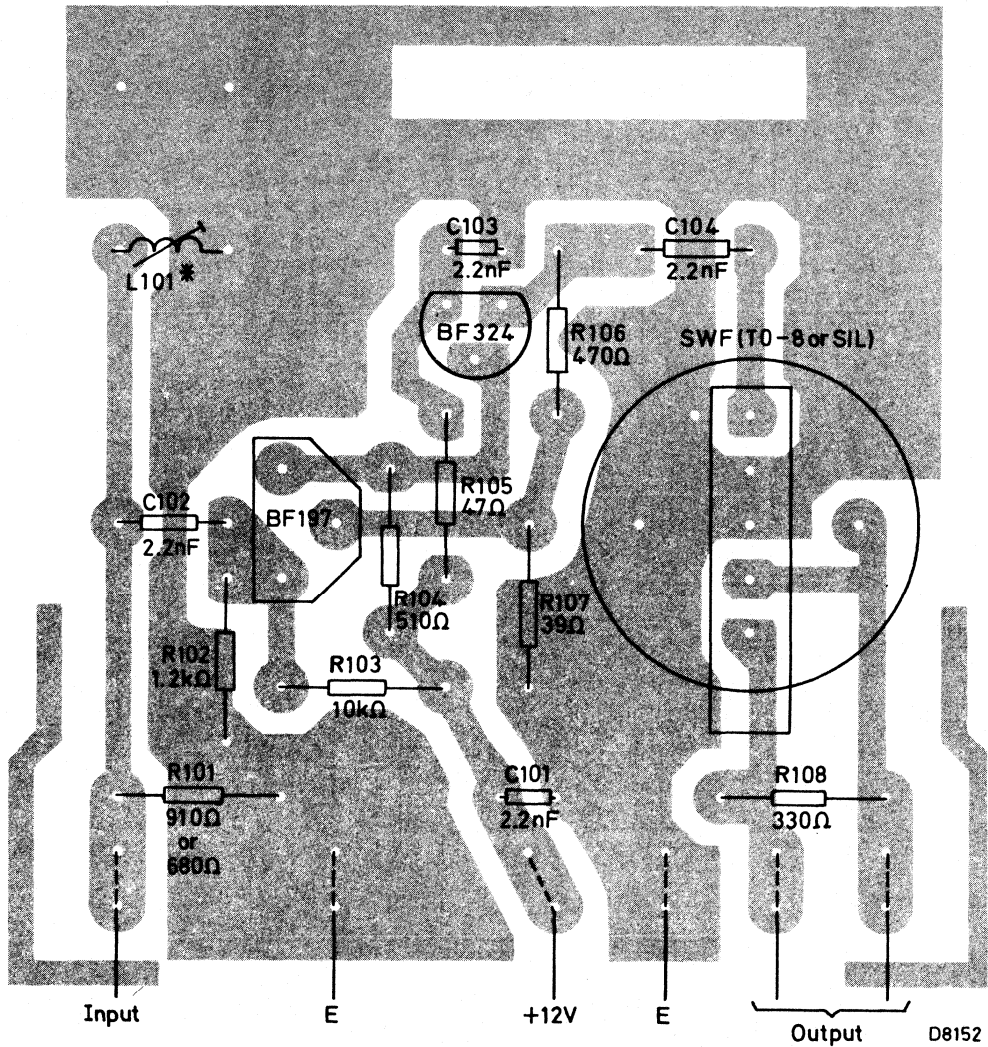

Fig.4



*If required, see circuit diagram

Fig.5 Recommended printed circuit board layout for surface acoustic wave filter and pre-amplifier

Contents

DATA HANDBOOK SYSTEM

F.M. TUNERS

	page
F.M. tuners	
AP2157/01	3
AP2158	11
FD1, FD1A	19
FD1B	27
FD1D	37
FD1F	43
FD11, FD11K	51

TELEVISION TUNERS AND AERIAL INPUT ASSEMBLIES

Television tuners	
ELC1042/05	3
ELC1043/05	17
ELC1043/06	29
ELC2000	31
ELC2004	49
ELC2060	65
ELC2070	83
ELC3082	97
U321, U321LO	109
U322, U322LO	123
V311	137
V314	151
V315, V315LO	165
Coaxial aerial input assemblies	
3122 127 10260	
3122 127 10450	
3122 127 14730	179

SURFACE ACOUSTIC WAVE FILTERS

Surface acoustic wave filters	
SW102/M	3
SW211/M	9



FM tuners

Television tuners and aerial input assemblies

Surface acoustic wave filters

Contents list

Argentina: FAPESA I y C., Av. Crovara 2550, Tablada, Prov. de BUENOS AIRES, Tel. 652-7438/7478.

Australia: PHILIPS INDUSTRIES HOLDINGS LTD., Elcoma Division, 67 Mars Road, LANE COVE, 2066, N.S.W., Tel. 427 08 88.

Austria: ÖSTERREICHISCHE PHILIPS BAUELEMENTE Industrie G.m.b.H., Triester Str. 64, A-1101 WIEN, Tel. 62 91 11.

Belgium: M.B.L.E., 80, rue des Deux Gares, B-1070 BRUXELLES, Tel 523 00 00.

Brazil: IBRAPE, Caixa Postal 7383, Av. Paulista 2073-S/Loja, SAO PAULO, SP, Tel. 284-4511.

Canada: PHILIPS ELECTRONICS LTD., Electron Devices Div., 601 Milner Ave., SCARBOROUGH, Ontario, M1B 1M8, Tel. 292-5161.

Chile: PHILIPS CHILENA S.A., Av. Santa María 0760, SANTIAGO, Tel. 39-40 01.

Colombia: SADAPE S.A., P.O. Box 9805, Calle 13, No. 51 + 39, BOGOTA D.E. 1., Tel. 600 600.

Denmark: MINIWATT A/S, Emdrupvej 115A, DK-2400 KØBENHAVN NV., Tel. (01) 69 16 22.

Finland: OY PHILIPS AB, Elcoma Division, Kaivokatu 8, SF-00100 HELSINKI 10, Tel. 1 72 71.

France: R.T.C. LA RADIOTECHNIQUE-COMPELEC, 130 Avenue Ledru Rollin, F-75540 PARIS 11, Tel. 355-44-99.

Germany: VALVO, UB Bauelemente der Philips G.m.b.H., Valvo Haus, Burchardstrasse 19, D-2 HAMBURG 1, Tel. (040) 3296-1.

Greece: PHILIPS S.A. HELLENIQUE, Elcoma Division, 52, Av. Syngrou, ATHENS, Tel. 915 311.

Hong Kong: PHILIPS HONG KONG LTD., Comp. Dept., Philips Ind. Bldg., Kung Yip St., K.C.T.L. 289, KWAI CHUNG, N.T. Tel. 12-24 51 21.

India: PHILIPS INDIA LTD., Elcoma Div., Band Box House, 254-D, Dr. Annie Besant Rd., Prabhadevi, BOMBAY-25-DD, Tel. 457 311-5.

Indonesia: P.T. PHILIPS-RALIN ELECTRONICS, Elcoma Division, 'Timah' Building, Jl. Gen. Gatot Subroto, JAKARTA, Tel. 44 163.

Ireland: PHILIPS ELECTRICAL (IRELAND) LTD., Newstead, Clonskeagh, DUBLIN 14, Tel. 69 33 55.

Italy: PHILIPS S.p.A., Sezione Elcoma, Piazza IV Novembre 3, I-20124 MILANO, Tel. 2-6994.

Japan: NIHON PHILIPS CORP., Shuwa Shinagawa Bldg., 26-33 Takanawa 3-chome, Minato-ku, TOKYO (108), Tel. 448-5611.
(IC Products) SIGNETICS JAPAN, LTD., TOKYO, Tel. (03) 230-1521.

Korea: PHILIPS ELECTRONICS (KOREA) LTD., Elcoma Division, Philips House, 260-199 Itaewon-dong, Yongsan-ku, SEOUL, Tel. 794-4202.

Mexico: ELECTRONICA S.A. de C.V., Varsovia No. 36, MEXICO 6, D.F., Tel. 533-11-80.

Netherlands: PHILIPS NEDERLAND B.V., Afd. Elonco, Boschdijk 525, NL 5600 PD EINDHOVEN, Tel. (040) 79 33 33.

New Zealand: PHILIPS Electrical Ind. Ltd., Elcoma Division, 2 Wagener Place, St. Lukes, AUCKLAND, Tel. 867 119.

Norway: NORSK A/S PHILIPS, Electronica Dept., Vitaminveien 11, Grefsen, OSLO 4, Tel. (02) 15 05 90.

Peru: CADESA, Rocca de Vergallo 247, LIMA 17, Tel. 62 85 99.

Philippines: ELDAC, Philips Industrial Dev. Inc., 2246 Pasong Tamo, MAKATI-RIZAL, Tel. 86-89-51 to 59.

Portugal: PHILIPS PORTUGESA S.A.R.L., Av. Eng. Duarte Pacheco 6, LISBOA 1, Tel. 68 31 21.

Singapore: PHILIPS SINGAPORE PTE LTD., Elcoma Div., P.O.B. 340, Toa Payoh CPO, Lorong 1, Toa Payoh, SINGAPORE 12, Tel. 53 88 11.

South Africa: EDAC (Pty.) Ltd., South Park Lane, New Doornfontein, JOHANNESBURG 2001, Tel. 24/6701.

Spain: COPRESA S.A., Balmes 22, BARCELONA 7, Tel. 301 63 12.

Sweden: A.B. ELCOMA, Lidingövägen 50, S-10 250 STOCKHOLM 27, Tel. 08/67 97 80.

Switzerland: PHILIPS A.G., Elcoma Dept., Edenstrasse 20, CH-8027 ZÜRICH, Tel. 01/44 22 11.

Taiwan: PHILIPS TAIWAN LTD., 3rd Fl., San Min Building, 57-1, Chung Shan N. Rd. Section 2, P.O. Box 22978, TAIPEI, Tel. 5513101-5.

Turkey: TÜRK PHILIPS TICARET A.S., EMET Department, Inonu Cad. No. 78-80, İSTANBUL, Tel. 43 59 10.

United Kingdom: MULLARD LTD., Mullard House, Torrington Place, LONDON WC1E 7HD, Tel. 01-580 6633.

United States: (Active devices & Materials) AMPEREX SALES CORP., Providence Pike, SLATERSVILLE, R.I. 02876, Tel. (401) 762-9000.
(Passive devices) MEPCO/ELECTRA INC., Columbia Rd., MORRISTOWN, N.J. 07960, Tel. (201) 539-2000.
(IC Products) SIGNETICS CORPORATION, 811 East Arques Avenue, SUNNYVALE, California 94086, Tel. (408) 739-7700.

Uruguay: LUZILECTRON S.A., Rondeau 1567, piso 5, MONTEVIDEO, Tel. 9 43 21.

Venezuela: IND. VENEZOLANAS PHILIPS S.A., Elcoma Dept., A. Ppal de los Ruices, Edif. Centro Colgate, CARACAS, Tel. 36 05 11.